

REVISION RECORD			
LTR	DESCRIPTION	DATE	BY
A	RELEASED	1/13/17	28045 GPL

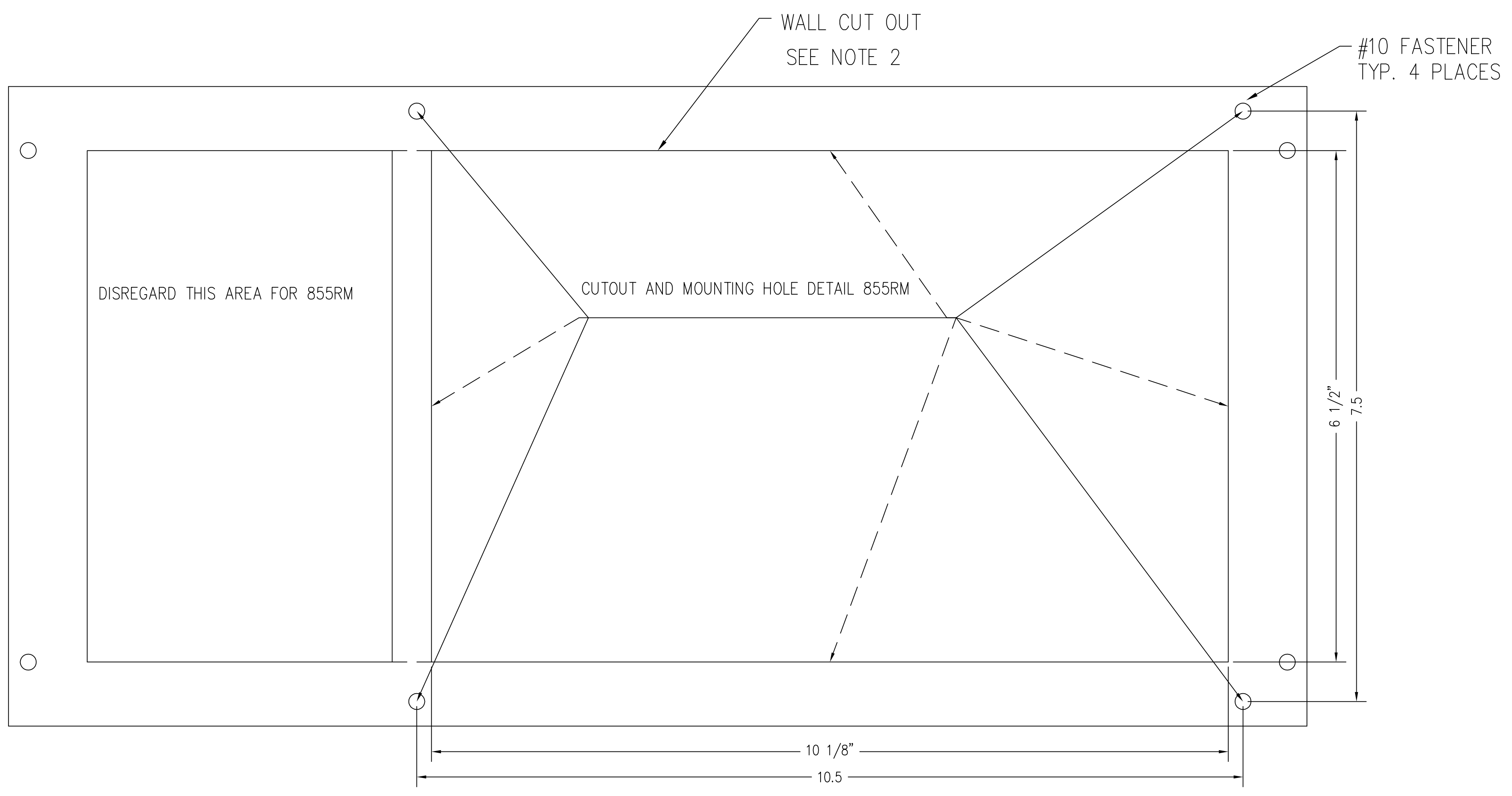

- MOUNTING INSTRUCTIONS**
1. CHOOSE YOUR LOCATION, MUST HAVE 14 1/2" MIN. BETWEEN STUDS.
 2. USE TEMPLATE PROVIDED, OR CUTOUT DETAIL TO LAYOUT OPENING TO BE CUTOUT AND TO MARK MOUNTING HOLE LOCATIONS.
 3. STANDARD 120 VAC WILL BE REQUIRED, WIRE PER LOCAL CODES.
 4. GROUNDING REQUIRED, GROUND PER LOCAL CODES.
 5. USE TEMPLATE 8555-C465-08.

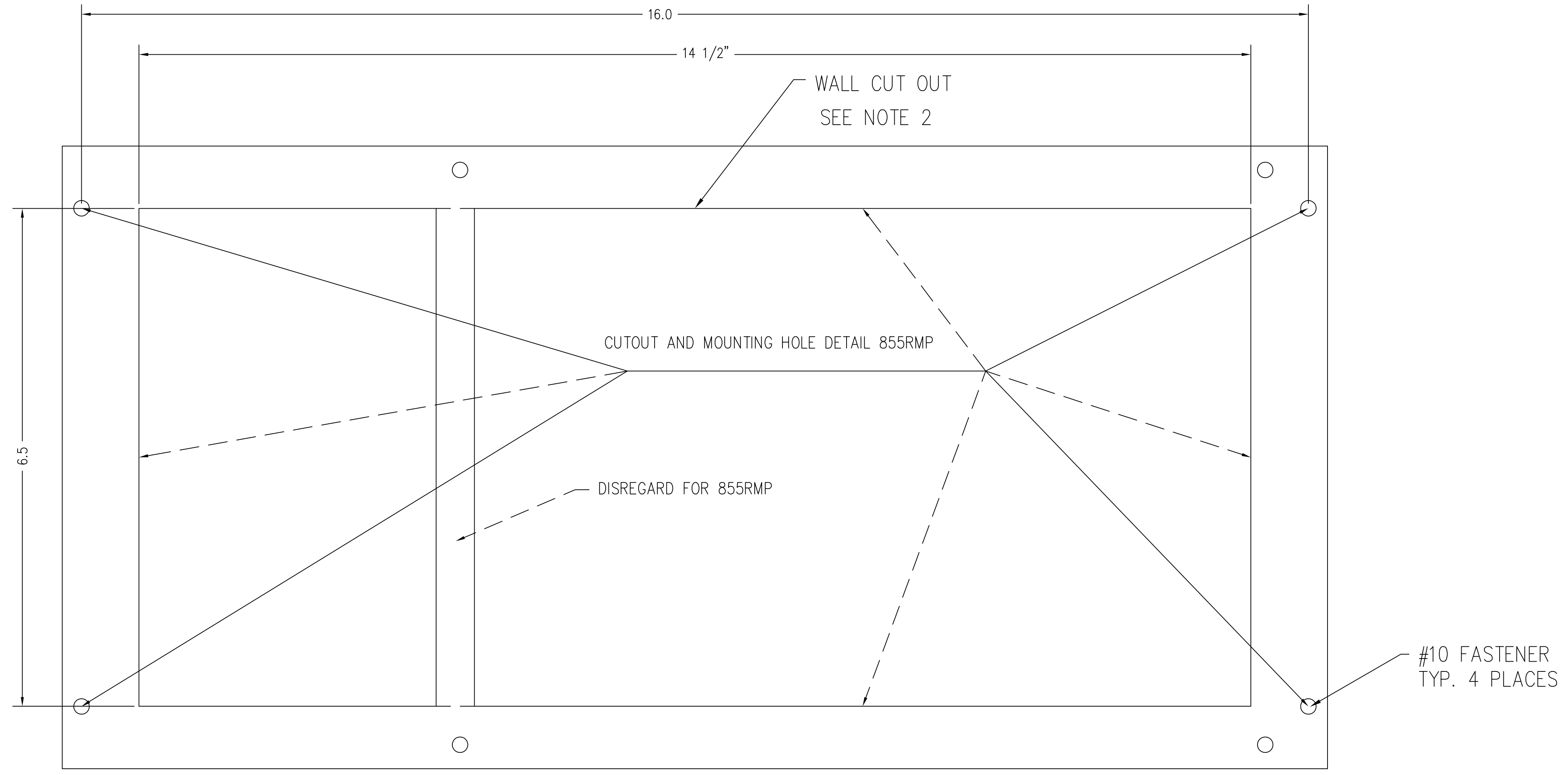

QTY.	QTY.	QTY.	ITEM	PART/DWG.	DESCRIPTION	MATERIAL OR	WT.	
			ASSY	NUMBER		SOURCE	EACH	
PARTS/MATERIAL LIST								
UNLESS OTHERWISE SPECIFIED TOLERANCE ON DIMENSIONS ARE: ANGLES ± 1/2° INTEGERS/FRACTIONS ± 1/16 IN. DECIMALS (.X) ± .03 IN. DECIMALS (.XX) ± .01 IN. DECIMALS (.XXX) ± .005 IN. NOTE: WHOLE NUMBERS MUST BE WRITTEN XX.000 TO INVOKE DECIMAL TOLERANCES.				 Cardinal Cardinal Scale Manufacturing Co. <small>WEBB CITY, MISSOURI, U.S.A. 64489</small>				CARDINAL DETECTO FULLER WEIGHING SYSTEMS
TITLE CUTOUT DETAILS 855RM/855RMP								
THIS DRAWING IS THE PROPERTY OF THE CARDINAL SCALE MFG. CO. AND SHALL NOT BE USED NOR REPRODUCED EITHER WHOLLY OR IN PART EXCEPT WITH WRITTEN AUTHORIZATION. ALL RIGHTS OF DESIGN OR INVENTION ARE RESERVED.		SCALE	NTS	DO NOT SCALE DRAWING	NEXT ASSEMBLY			
		DR.	GPL	DATE	1/13/17			
		CH.		DATE				
		MODEL	ID-XXXXS-XXX	SHEET	1 OF 1	DWG. NO.	1914-0044-GS	
						REV.	A	