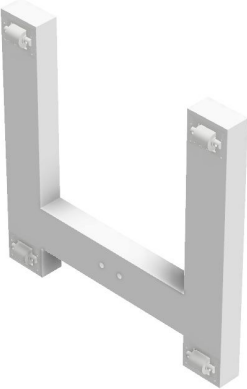
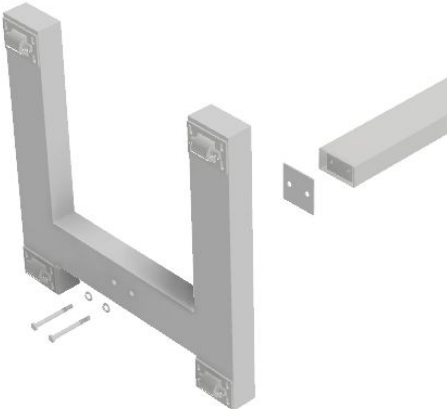

Mobile Multiple Apron Hanger with 10 Swing Arms,

Tools required.

- 2 personnel will be required to construct this unit
- Adjustable Wrench
- Socket Wrench

Instructions

Step	Description	Picture
1	Loosen all screws to ensure no obstructions are within are within the cavities.	
2	In the 1st sub-assembly, the parts needed are: "H" Base, 2 Large Bolts, 2 Split Washers, Small Plate, Support Column. Place "H" shaped base on its side. This will leave the 2 circular holes facing right and Casters Wheels facing left.	
3	Assemble the support beam to the "H" base to the Support column. From the bottom the arrangement should be: Support Bolts, Split Washers, "H" base, Small Plate, and Support Column. This process will have to be performed two times. Tighten these bolts.	

Mobile Multiple Apron Hanger with 10 Swing Arms,

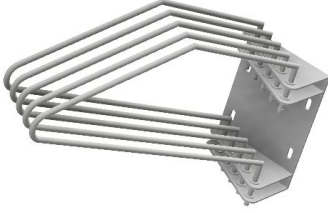
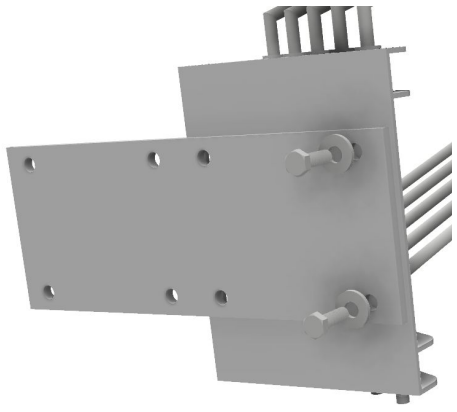
4	<p>In the 2nd sub-assembly, the parts that will be needed are: 2 Small Bolts, 4 Medium/Small Washers, 2 Medium/Small nuts, Large Plate, 1 Hanger Support.</p> <p>The is the front View of Hanger Support .</p> <p>No not use any tools to tighten the next few steps. (Step 5, Step 6, and Step 7)</p>	
5	<p>To start this sub-assembly, place the Large Plate on a surface and then feed the bolts in from the back of the Small Plate and back of the Hanger Support.</p> <p>The pieces should go Small Bolt, Medium/Small Washer Large plate, Hanger Support, Medium/Small Washer, and Medium/Small Nut.</p> <p>Notice the outermost holes were used by the Bolts.</p>	

Mobile Multiple Apron Hanger with 10 Swing Arms,

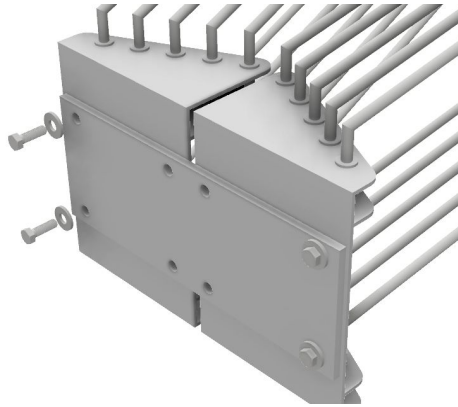
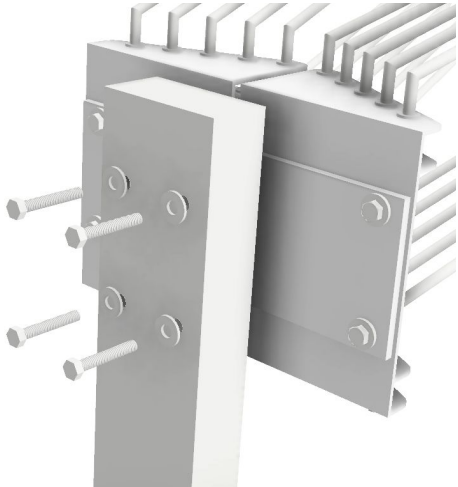
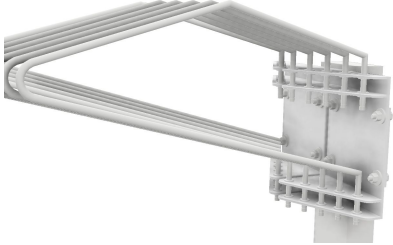
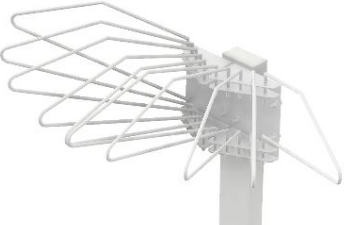
6	<p>Repeated this process for the remaining Hanger Support. Do not use the middle holes.</p>	 A 3D rendering of a hanger support assembly. It consists of a rectangular metal plate with 10 vertical swing arms extending from the top edge. The plate has several holes and is secured with bolts on the left side.
7	<p>In this step we will combine the 2 assemblies together. You will have to use the 4 Medium size Bolts, 8 Medium/Small washers, and 4 Medium/Small nuts.</p>	 A 3D rendering showing two hanger support assemblies from the previous step being joined together. A vertical plate is being inserted between the two assemblies, and bolts are being used to secure them together.
8	<p>Tighten all loose screws and bolts.</p>	 A 3D rendering of the hanger support assembly with the swing arms bent into a U-shape. The assembly is shown from a side perspective, highlighting the curved arms.
8	<p>Adjust arm to desired angles.</p>	 A 3D rendering of the hanger support assembly with the swing arms adjusted to various angles. The arms are shown in a fan-like arrangement, demonstrating their flexibility.

Mobile Multiple Apron Hanger with 10 Swing Arms,

