



OWNER'S MANUAL

FusionONE+ Power Exam Table

3501/3502/3503

Fusion**ONE+**™



SERIAL NUMBER

DATE OF MANUFACTURE

MAXIMUM PATIENT WEIGHT 500 LBS / 226 KG

INTENDED USE STATEMENT

The FusionONE+ Power Exam Table with power back provides a surface on which patients can sit and/or lie while a qualified medical professional performs a medical examination and/or treatment. This exam table has standard features that allow the table to be raised and lowered, the backrest to be inclined or declined, and the patient's legs to be supported in an elevated position. The features make examining and treating patients more ergonomic and allows easy accessibility for the medical professional.

IMPORTANT INFORMATION

Safety First: This equipment must be operated and maintained with the safety of the patient and medical professional in mind.

- ① No individual should operate table without reading and understanding the owner's manual. Read this manual completely before operating your new UMF Medical equipment. There is no special training required to operate this equipment.
- ② Patients should only mount and dismount the table from the front and only when the table is at a comfortable height for their respective height.
- ③ This product is intended to be used for positioning of patients during medical examinations conducted by a qualified medical professional.
- ④ This manual should remain permanently affixed or near the equipment for convenient reference.
- ⑤ Do not attempt to transport table without proper lifting equipment.
- ⑥ Do not leave table with unsupervised children.
- ⑦ Use adhesive caution tape or cable runner if power cord is run across the floor.
- ⑧ UMF Medical reserves the right to make changes to the design of products at any time and without notice.
- ⑨ If table becomes unresponsive while at a raised position with a patient on the table, use a step stool, chair, or other form of secure step to help the patient safely dismount the table.
- ⑩ Do not impede the table's movement when raising or lowering. Doing so can cause damage to table and or item/person in contact with table.
- ⑪ Table can be lifted from the rear underside of the body panel (under the drawer) and in the front by pulling out the leg section approximately 4" and using it as a hand hold. Table should always be lifted by two people at a time who are capable of lifting 175 lbs (79 kg) each. Table should be lifted onto a dolly or cart capable of holding 350 lbs (159 kg) for transporting long distances.

CLASSIFICATIONS

Equipment Class – 3501 Class II, 3502 Class II, 3503 Class I

Protection against electric shock: Type B applied parts

Protection against harmful ingress of water: Ordinary Equipment is not suitable for use in the presence of a flammable anesthetics mixture with air or with oxygen or with nitrous oxide

Mode of Operation: Continuous operation with intermittent loading 1 minute on, 9 minutes off, or 2 minutes on, 18 minutes off.

The table, any manufacturer approved accessories, and all accompanying documents are all part of the Medical Equipment System and suitable for use within the patient environment.

E514804 MEDICAL – GENERAL MEDICAL EQUIPMENT AS TO ELECTRICAL SHOCK, FIRE AND MECHANICAL HAZARDS ONLY IN ACCORDANCE WITH ANSI/AAMI ES60601-1:A1:2012,C1:2009/®2012 AND A2:2010/®2012, CSA CAN/CSA-C22.2 NO.60601-1:14, IEC 60601-1 EDITION 3.1 (2012)

UMFmedical Medical Equipment
Model: 3501
S/N: 123456-0001
Built: Jan 14, 2022

UMFmedical Medical Equipment
Model: 3502
S/N: 123456-0001
Built: Jan 14, 2022

UMFmedical Medical Equipment
Model: 3503
S/N: 123456-0001
Built: Jan 14, 2022

120 VAC 10 AMP/220 VAC 5.5 AMP 50-60 HZ
1316 Eisenhower Blvd
JOHNSTOWN, PA - MADE IN THE USA



120 VAC 10 AMP/220 VAC 5.5 AMP 50-60 HZ
1316 Eisenhower Blvd
JOHNSTOWN, PA - MADE IN THE USA



120 VAC 10.5 AMP/220 VAC 5.8 AMP 50-60 HZ
1316 Eisenhower Blvd
JOHNSTOWN, PA - MADE IN THE USA



APPLIED PARTS

The entire table is considered to be an applied part because the patient or medical professional could come in contact with any part of the table while in use. It is noted that the only components designed to come in contact with the patient on a regular occurrence are the upholstered top, leg pad, and stirrups.

WARNINGS AND SAFETY NOTICES

- ① No part of this exam table is to be serviced or maintained while in use with a patient.
- ② To avoid the risk of electric shock, this equipment must only be connected to a supply mains with protective earth.
- ③ Position the exam table so that the power cord can be quickly disconnected in an emergency.
- ④ In case of emergency, do not press any buttons on the hand or foot control. The exam table can be safely shut down by disconnecting the power cord.
- ⑤ No modification of this equipment is allowed. Any modification could cause harm to the patient or medical professional.
- ⑥ All service to exam table must be done by a certified Biomedical Technician.
- ⑦ The following items may only be replaced by a certified Biomedical Technician. Instructions for proper replacement can be found in the FusionONE+ Power Exam Table Service Manual. All wiring schematics and component parts list are also provided in the Service Manual. Improper replacement of any item could result in severe injury.

- | | | |
|-------------------------|-----------------|----------------|
| - Top Upholstery | - Stirrups | - Power Cord |
| - Leg Section | - Back Actuator | - Hand Control |
| - Pelvic Tilt Mechanism | - Lift Column | - Foot Control |
| - Body Panels | - Control Box | |

- ⑧ It is the responsibility of the owning facility to clean, sterilize, and disinfect the exam table according to the EQUIPMENT CARE section within this manual.
- ⑨ Inspect the exam table monthly for damaged areas that occur from use that may cause sharp corners or safety concerns.
- ⑩ Perform electrical outlet testing per facility requirements or local code, whichever is more frequent.
- ⑪ For shipping, the exam table must be secured to a pallet capable of transporting 350 lbs. (159 kg) without damage.
- ⑫ All service and modifications during the service life of the exam table will be conducted to the standards of IEC60601-1, ed 3.

SAFETY SYMBOLS

WARNING: The warning symbol identifies special instructions or procedures, which if not correctly followed could result in personal injury.

CAUTION: The caution symbol identifies special instructions or procedures, which if not properly followed could result in danger or damage to equipment.



CLASS II EQUIPMENT



TYPE B APPLIED PART



ATTENTION, CONSULT
ACCOMPANYING DOCUMENTS



PROTECTIVE
EARTH GROUND



REFER TO OWNER'S MANUAL



GENERAL WARNING



HOT SURFACE



DO NOT SIT



DO NOT STAND

ENVIRONMENTAL CONDITIONS

TRANSPORT/STORAGE TEMPERATURE: 14°F to 122°F (-10°C to 50°C)

TRANSPORT/STORAGE/OPERATING HUMIDITY: 20% to 90%

OPERATING TEMPERATURE: 41°F to 113°F (5°C to 45°C)

EMC INFORMATION

1. This ME Equipment is intended for use in the professional healthcare setting.
2. **WARNING:** Use of this equipment adjacent to or stacked with other equipment should be avoided because it could result in improper operation. If such use is necessary, this equipment and the other equipment should be observed to verify that they are operating normally.
3. Maximum length of the power supply cable is not to exceed: 10 ft. (3.0 m)
Maximum length of the hand/foot control cable is not to exceed: 10 ft. (3.0 m)
4. **WARNING:** Use of accessories, transducers and cables other than those specified or provided by the manufacturer of this equipment could result in increased electromagnetic emissions or decreased electromagnetic immunity of this equipment and result in improper operation.
5. **WARNING:** Portable RF communications equipment (including peripherals such as antenna cables and external antennas) should be used no closer than 30 cm (12 inches) to any part of the [ME EQUIPMENT or ME SYSTEM], including cables specified by the manufacturer. Otherwise, degradation of the performance of this equipment could result.
6. There are no maintenance requirements specifically related to EMC, all maintenance items are addressed in the important information section

SPECIFICATIONS

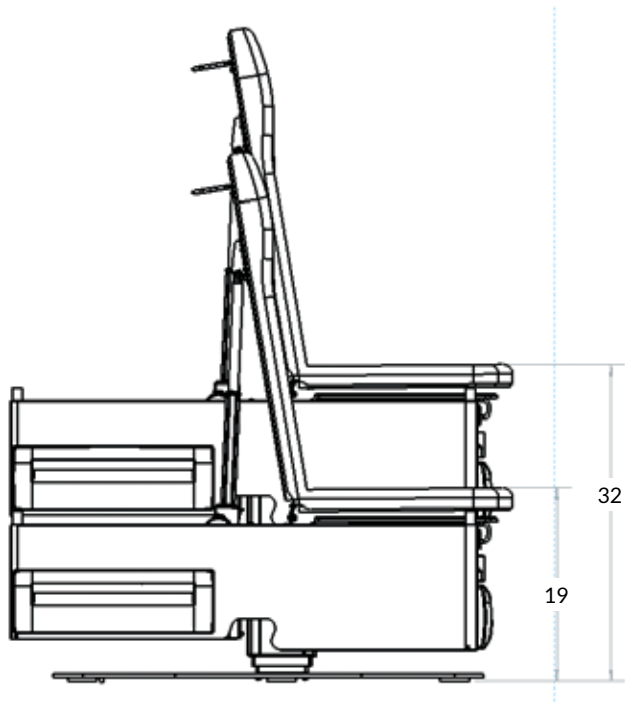

Maximum Patient Weight	500 lbs (226 kg)
3501/3502	
Electrical Supply(Standard)	120V 60Hz 10AMP
Electrical Supply(Optional)	220 60Hz 5.5AMP
3503	
Electrical Supply(Standard)	120V 60Hz 10.5AMP
Electrical Supply(Optional)	220 60Hz 5.8AMP
Power Cord Length	10 FT (3.0 m)
Table Weight	350 lbs (159 kg)
Paper Roll (Maximum size)	21" Long x 3.5" Diameter (53 cm x 9 cm)
Storage Drawer (Front)	19" W x 12" D x 3.5" H (48 cm x 30 cm x 9 cm)
Storage Drawer (Side)	24.5" W x 12.5" D x 3.5" H (62 cm x 32 cm x 9 cm)

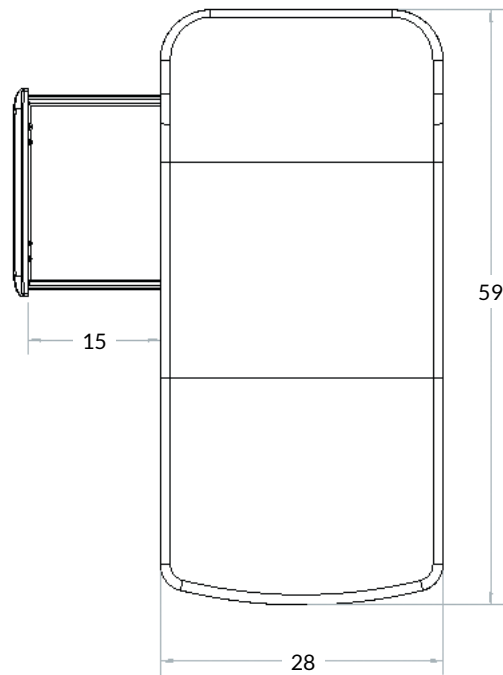
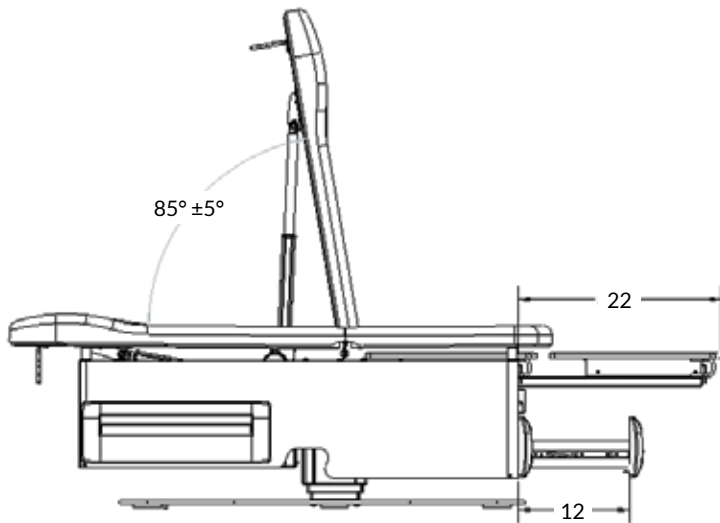

FEATURES AND OPERATION

Hand & Foot Control – Table Operation

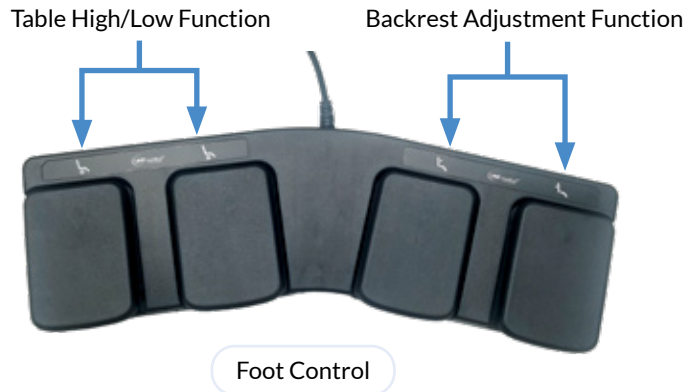

Hand Control

Optional, field-installable accessory



Table High/Low Function Operation:

Foot Control:

- 1 Press and hold the “up” button to raise the table
- 2 Press and hold the “down” button to lower the table

Optional Hand Control:

- 1 Press and hold the “up” button to raise the table
- 2 Press and hold the down “button” to lower the table

WARNING: DO NOT PLACE FOOT CONTROL ON BASE DURING OPERATION



Backrest Adjustment

Foot Control:

- 1 Press and hold the “up” button to raise the backrest
- 2 Press and hold the “down” button to lower the backrest

Optional Hand Control:

- 1 Press and hold the “up” button to raise the backrest
- 2 Press and hold the “down” button to lower the backrest

WARNING: DO NOT USE BACKREST AS A SEAT. BACKREST IS NOT DESIGNED TO SUPPORT PATIENT’S FULL WEIGHT

WARNING: DO NOT PLACE HANDS OR FINGERS NEAR THE BACK ACTUATOR OR BACKREST HINGE DURING BACKREST ADJUSTMENT

FEATURES AND OPERATION

Storage Drawers



Side Drawer
21" x 17.5" x 5"
(53 cm x 44 cm x 13 cm)



Front Drawer
18" x 12" x 3"
(46 cm x 30 cm x 8 cm)

Products placed in optional warming drawer should be checked for proper temperature before use.
Maximum weight for each drawer is not to exceed 10 lbs. (4.5 kg).

Drain Pan



- 1 Slide the drain pan drawer out to access drain pan.
- 2 Push drain pan drawer back in when not in use.
- 3 Drain pan can lift out of the drawer for cleaning purposes.

WARNING: DO NOT USE DRAWER OR DRAIN PAN AS A SEAT OR STEP.

Leg Rest



- 1 Slide leg section forward until it contacts the two stopper pins.
- 2 When not in use, push the leg section in to stow.
- 3 Leg rest capacity should not exceed 100lbs. (45 kg)

WARNING: DO NOT USE THE LEG REST AS A SEAT OR STEP.

FEATURES AND OPERATION

Paper Roll Replacement



Max Roll Size
21" x 3.5" (53 cm x 9 cm)

Slide paper roll off bracket, and slide new paper roll on bracket.

Stirrup Positioning & Adjustment



- 1 Pull the stirrups out and unfold.
- 2 Lift slightly and move left or right to desired position.
- 3 Release stirrup to lock into position.

WARNING: DO NOT SUPPORT THE PATIENT'S ENTIRE WEIGHT WITH THE STIRRUPS. ENSURE STIRRUPS ARE PROPERLY LOCKED PRIOR TO ENGAGING PATIENT'S FEET. DO NOT USE THE STIRRUPS TO LIFT THE TABLE.

Pelvic Tilt



- 1 Lift up the seat, and the pelvic tilt rod will automatically fall into place.
- 2 To disengage pelvic tilt, lift seat and flip the lever on either side of the seat bottom.

WARNING: ENSURE PELVIC TILT ROD IS LOCKED AND HANDS ARE NOT UNDERNEATH BUMPER WHEN LOWERING SEAT SECTION.

FEATURES AND OPERATION

Reversing Side Drawers



Step 1:

Remove side panel with a screwdriver.



Step 2:

- Remove drawer
- › Extend drawer
 - › Slide both tabs, located in the track under the drawer, to the side and hold
 - › Remove drawer



Step 3:

Slide cages to opposite side of table.

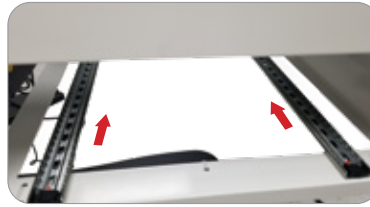

Step 4:

- Align slides and install drawer on opposite side.
- › Ensure slide cages are to the front of the track
 - › Align both drawer tracks with the slide cages
 - › Slide drawer in completely



Step 5:

Install side panel on opposite side with a screwdriver.

COMMON OPTIONS AND ACCESSORIES

Drawer Warmer



- ① Press switch to power “on” and “off”.
- ② When switch is in the “on” position, switch will illuminate indicating drawer warmer is activated.
- ③ During normal operation, the front drawer and its contents should be between 100°F (38°C) and 110°F (43°C). If temperatures exceed 120°F (49°C) contact UMF Medical Customer Service.

WARNING: THE HEATING ELEMENT FOR THE DRAWER WARMER IS LOCATED IN A PANEL ABOVE THE DRAWER, THIS PANEL WILL BE HOT WHILE DRAWER WARMER IS “ON” AND IS NOT TO BE TOUCHED.

COMMON OPTIONS AND ACCESSORIES

Hospital Grade Receptacle



WARNING: OUTLET IS FOR MEDICAL EQUIPMENT ONLY.
CAUTION: CHECK GROUND CONTINUITY PERIODICALLY.
120V MAXIMUM OUTPUT - 5.0A, 120V
220V MAXIMUM OUTPUT - 3.0A, 220V

WARNING: MULTIPLE SOCKET OUTLET LOCATED ON SIDE OF TABLE IS TO BE USED FOR MEDICAL EQUIPMENT ONLY (WHERE SAFETY CERTIFICATION HAS BEEN PERFORMED IN ACCORDANCE WITH IEC 60601-1 AND/OR IEC 60601-1-1). USE OF EQUIPMENT NOT COMPLYING WITH THE EQUIVALENT SAFETY REQUIREMENT OF THIS EQUIPMENT MAY LEAD TO A REDUCED LEVEL OF SAFETY OF THE RESULTING SYSTEM. THE MULTIPLE SOCKET OUTLET LOCATED ON THE BACK SIDE OF THE PANEL, ON THE INSIDE OF THE TABLE, IS TO BE USED FOR THE POWER SUPPLY FOR THE CONTROL BOX ONLY THIS OUTLET SHOULD NOT BE USED FOR ANY OTHER ITEMS.

WARNING: GROUND RELIABILITY CAN ONLY BE ACHIEVED WHEN POWER SUPPLY IS CONNECTED TO AN EQUIVALENT RECEPTACLE MARKED "HOSPITAL ONLY" OR "HOSPITAL GRADE". WARNING: ADDITIONAL EXTENSION CORD OR MULTI-SOCKET OUTLET IS NOT TO BE CONNECTED TO TABLE.

Service Note: If the maximum load of the receptacle is exceeded, two circuit breakers will interrupt power. To reset, toggle the far two circuit breakers located behind the receptacle outlet box in the back of the drawer panel.

COMMON OPTIONS AND ACCESSORIES

Bierhoff Knee Crutch (251-Pair)



- ① Extend stirrups to full-extended position with heel stirrup in retracted position.
- ② Insert knurled end of knee crutch rod into hole on end of stirrup.
- ③ Adjust to position and tighten with slide lock.

Plug Power Cord Into Wall Outlet



- 1 This is an image of the table's power cord plugged into a standard wall outlet.

Note: The table does not have an on/off switch so whenever the power cord is plugged in, the table is operable.

EQUIPMENT CARE

Proper Sterilization Instructions

Care of upholstery

The upholstery material used on the top, leg rest, an headrest is resistant to most medical stains.

For light cleaning:

- 1 A solution of 10% liquid soap and clean water applied with a soft damp cloth will remove disinfection cleaner build-up.
- 2 If necessary, a solution of liquid cleanser and water can be applied with a soft bristle brush. Wipe away residue with a water-dampened cloth.

For disinfection:

- 1 Dampen a soft white cloth with a solution of standard bleach (sodium hypochlorite) or other chlorine-based cleaner*** and water; 10% bleach, 90% water.
- 2 Rub gently.
- 3 If necessary, allow the 1:10 diluted bleach (sodium hypochlorite) solution to puddle on the affected area or apply with a clean, soaked cloth for approximately 30 minutes. Rinse with a water-dampened cloth to remove any remaining bleach concentration.
- 4 Rinse with a water-dampened cloth to remove cleaner solution and allow thorough drying of material.

***See current CDC Guideline for Disinfection & Sterilization in Healthcare Facilities for bleach alternative cleaners.

Note: Immediately remove any fluid spilled on upholstery surface.

Antimicrobial: UMF Medical Upholstery provides outstanding protection in difficult medical and healthcare environments and contains an agent effective against bacterial and fungal microorganisms.

Care of painted surfaces

A chemical acid-resistant paint is used, but extreme care must be taken not to use ammonia-based cleaners or discoloration of paint may occur. A damp cloth or mild liquid soap solution should be sufficient.

Care of bright metal surfaces

All non-painted surfaces, chrome plated, or stainless steel should be wiped weekly with a clean damp cloth then buffed to a lustrous shine with a soft dry cloth.

Care of base

The protective base is easily washable with mild liquid soap and water. A soft bristle brush may be used on scuffed stained areas.

CAUTION: WHEN THE USE OF STRONG CLEANING SOLUTIONS IS NECESSARY, TEST AN INCONSPICUOUS AREA TO ASSURE THAT DAMAGE TO UPHOLSTERY OR PAINTED SURFACES WILL NOT OCCUR.

Upholstery with PreFixx® Protective Finish

In laboratory testing, upholstery protected with PreFixx® finish was treated with the following disinfectants with little to no discoloration or damage to the upholstery. This testing may not reflect actual results in the field.*

Recommended Disinfectants

- › Clorox® Broad Spectrum Quaternary Disinfectant Cleaner
- › Clorox® Healthcare Bleach Germicidal Cleaner
- › Clorox® Healthcare Bleach Germicidal Wipes
- › Clorox® Healthcare EZ-KILL® Wipes
- › Clorox® Healthcare VersaSure® Cleaner Disinfection Wipes
- › Clorox® Hydrogen Peroxide Cleaner Disinfectant Spray
- › Clorox® Hydrogen Peroxide Cleaner Disinfectant Wipes
- › Agar™ Powerquat
- › Asepticare™
- › Asepticare™ TB-II
- › AVISTAT-D™ Ready To Use Spray Disinfectant Cleaner
- › Biotrol BirexSE®
- › Bleach 1:5 (20% bleach)
- › Bleach 1:9 (10% bleach)
- › Bleach-Rite® Disinfecting Spray
- › CaviCide™
- › CaviCide1™
- › CaviCide™ AF
- › Diversey™ Accel® INTERvention® Wipes
- › Diversey™ Avert® Sporidical Disinfectant Cleaner
- › ERC Performance Wipes
- › McKesson Disposable Germicidal Surface Wipes
- › McKesson Pro-Tech RTU Disinfectant Cleaner
- › OPTIM® 1 Wipes
- › OPTIM® 33TB
- › Oxivir® 1 RTU
- › Oxivir® Five 16
- › Oxivir® TB
- › OxyCide™ Daily Disinfectant Cleaner
- › PDI Sani-Cloth® AF3 Germicidal Disposable Wipes

EQUIPMENT CARE

- › PDI Sani-Cloth® HB
- › PDI Sani-Cloth® Plus
- › PDI Sani-Cloth® Prime Germicidal Disposable Wipe
- › PDI Super Sani-Cloth®
- › PDI Super Sani-Cloth® Bleach Germicidal Disposable Wipes
- › Precise QTB Spray
- › PROCHEM® Oxy Plus
- › Purell® Healthcare Surface Disinfectant
- › Purell® Multi-Surface Disinfectant
- › Sani Professional® Cleaning + Degreasing Multi-Surface Wipes
- › Sani Professional® Multi-Surface Cleaning Wipes
- › Sani Professional® No-Rinse Sanitizing Multi-Surface Wipes
- › SaniZide® Plus
- › STERI-7 XTRA CONCENTRATE (recommended dilution ratio 1:10)
- › STERI-7 XTRA WIPES
- › Vert-2-Go ED
- › Virox AHP 5

- › Virox PREempt™ RTU
- › Virex® II 256
- › Virex® Plus One-Step Disinfectant Cleaner & Deodorant
- › Wayne® Concept 256N
- › Wex-Cide 128

Care & Cleaning

Use one of the following cleaners with a soft cloth or damp sponge. Rinse area with fresh water then dry with a clean, lint-free cloth.

Primary Recommended Cleaner

- › Formula 409 All-Purpose spray cleaner
- › Fantastik spray cleaner

Secondary Recommended Cleaners

- › Lysol Clean and Fresh Multi-Surface Cleaner (Reckitt Benckiser)
- › Lestoil Heavy Duty Cleaner (Clorox)

- › Mr. Clean / Flash Clean and Shine (Procter and Gamble)
- › Eco Touch All Purpose Premium Care

For more difficult stains, contact UMF Medical Customer Service.

**All disinfectants and cleaning agents contain chemicals that degrade coated fabric upholstery to some extent. To promote a long product life, it is recommended that the PreFixx cleaning and maintenance protocol be employed regularly.*

***Inclusion in this document does not imply "fit for use." Customers should first determine if products are appropriate for use on their surfaces.*



*

DISPOSAL INFORMATION

- 1 When disposing of your equipment, there are no batteries, harmful chemicals, or other potentially hazardous items contained within the equipment that require any special disposal precautions.
- 2 Metal, plastic, and other components of table can be disassembled and recycled if desired.

WARRANTY INFORMATION

Warranty Program

UMF Medical warrants to the original purchaser a warranty for products to be free from functional defects in material and workmanship under normal interior use and service. UMF Medical's obligation under this warranty is limited to the repair or replacement, at UMF Medical's option, of the parts or the products the defects of which are reported to UMF Medical within the applicable warranty period and which upon examination by UMF Medical prove to be defective. Warranty subject to the terms and conditions listed below.

Length of warranty, measured by Purchase Date (Invoice Date), for all warranted products and components:

<i>Five years:</i>	Signature Series Examination Tables (52xx model numbers and Treatment and Orthopedic Tables (55xx model numbers). Ultra-Comfort adjustable backrest cylinder not included.
<i>Three years:</i>	Power Exam and Procedure Tables and all other UMF Medical products excluding the products listed in Five Year and One Year categories of this document.
<i>One year:</i>	Waste Receptacles, Bassinet Baskets, Bassinet Mattresses and ultra-comfort adjustable backrest cylinder.

Obtaining Warranty Service

Warranty service must be obtained by contacting either the Authorized Distributor through whom the product was purchased or UMF Medical Customer Service Department via phone at 814-266-8726, or via email at customerservice@umfmedical.com.

This warranty covers the cost associated with the repair parts only and does not cover any other charges, including but not limited to service calls, labor, transportation, shipping, etc. It is the retail customer's obligation to arrange delivery of a product to UMF Medical or one of its authorized distributors for warranty service, which delivery shall be at the retail purchaser's expense. It is also the retail purchaser's obligation to comply with the warranty service instruction provided by UMF Medical or its authorized distributor. The retail purchaser must provide UMF Medical with completed warranty registration information within thirty days after purchase in order to obtain the benefits of this warranty.

Limited warranty general exceptions and exclusions

This warranty does not cover and UMF Medical shall not be liable for the following:

- › Parts and products of a consumable nature;
- › Defects, damage or other conditions caused, in whole or in part, by mishandling, misuse, abuse, negligence, alteration,

accident, freight damage, tampering or failure to seek and obtain repair or replacement in a timely manner;

- › Products which are not installed, used, and properly cleaned and maintained as required in the UMF Medical installation and/or Owner's Manual for the applicable product;
- › Replacement parts, alterations or installation of any accessories or parts not manufactured or recommended by UMF Medical;
- › Cosmetic and non-functional defects not noted at time of delivery.
- › Charges for repairs, replacement parts, adjustments, installation or other work performed upon or in connection with products which are not expressly authorized in writing in advance by UMF Medical.
- › Damages resulting from inadequate power supply (including incorrect voltage, voltage spikes or other irregularities) or use or storage in corrosive atmospheres.

To the extent any or all of the following exclusions or provisions of this warranty are prohibited by any federal, state, or municipal law which cannot be preempted, those exclusions or provisions shall not be applicable.

Exclusive Remedy: Consequential Damages Disclaimer

UMF Medical's only obligation under this warranty is the repair or replacement of defective parts. UMF Medical shall not be liable for and hereby disclaims any direct, special, indirect, incidental, exemplary or consequential damages or delays, including but not limited to, damages for loss of profits or income, loss of use, downtime, employee or independent contractor wages, payments and benefits, commercial loss or other incidental charges.

No Authorization

No person or firm is authorized to create or approve for UMF Medical any other obligation or liability in connection with the products.

Warranty Disclaimer

THIS WARRANTY IS UMF MEDICAL'S ONLY WARRANTY AND IS IN LIEU OF ALL OTHER WARRANTIES, EXPRESS OR IMPLIED. UMF MEDICAL MAKES NO IMPLIED WARRANTIES OF ANY KIND INCLUDING ANY IMPLIED WARRANTIES OR MERCHANTABILITY OR FITNESS FOR A PARTICULAR PURPOSE. THIS WARRANTY IS LIMITED TO THE REPAIR OR REPLACEMENT OF DEFECTIVE PARTS.

No action may be brought against UMF Medical for breach of this limited warranty, an implied warranty, if any, or for any other claim arising out of or relating to the products following expiration of the limited warranty period.

UMF Medical reserves the right to make changes in the design or material of its products without incurring any obligation to incorporate such changes in any product previously manufactured.

This page intentionally left blank



Fusion**ONE+**TM