

# Health o meter<sup>®</sup>

P r o f e s s i o n a l

## Model 498KL / 498KL-USB Remote Display Digital Scale



## User Instructions

E112697  
UL 60601-1  
CSA C22.2 No. 601.1-M90

Para ver las instrucciones de uso en español visita [www.homscales.com](http://www.homscales.com)  
Pour les instructions de l'utilisateur dans la visite française [www.homscales.com](http://www.homscales.com)



PELSTAR, LLC 9500 West 55th St. McCook, IL 60525-7110 USA  
Health o meter<sup>®</sup> Professional 498KL

[www.homscales.com](http://www.homscales.com)

© Pelstar, LLC 2021

weigh**easier**<sup>®</sup>

# Health o meter®

P r o f e s s i o n a l

Health o meter® Professional 498KL  
Health o meter® Professional 498KL-USB

Thank you for purchasing this Health o meter® Professional product. Please read this manual carefully, and keep it for easy reference or training.

## TABLE OF CONTENTS

Caution and Warning.....	3
Specifications for This Scale .....	4
Certifications / Disposal.....	5
Assembly Instructions 498KL Scale .....	6
Display Bracket Assembly Instructions .....	7
Display Wall Mount Instructions .....	8
Powering the Scale .....	9
Set Up Instructions.....	10
Operating Instructions .....	11
Transport.....	14
Maintenance.....	15
Calibration .....	16
Troubleshooting .....	17
Warranty.....	18

**Note: This scale has been factory calibrated, and does not require calibration prior to use.**

Please register your scale for warranty coverage at:

[www.homscales.com](http://www.homscales.com)

For User Instructions updates and revisions please go to:

[www.homscales.com](http://www.homscales.com)

# CAUTION AND WARNING

## **INTENDED USE**

This Health o meter® Professional scale is intended to be used in a professional medical environment by trained medical staff. This product was designed to weigh patients who are safely positioned and standing on the platform. The intended use of the height rod is to measure patient height. Do not modify the product or use it for anything other than its intended purpose.

**To prevent patient/caregiver injury or damage to your scale, please follow the instructions in this user manual very carefully.**

- Do not exceed the weight capacity specified for this scale.
- For accurate weighing, this scale must be placed on a flat, stable surface.
- For accurate weighing, verify before each use the proper operation according to the procedure described in this manual.
- Do not use in the presence of flammable or explosive materials.
- If the scale becomes damaged, it should not be operated until properly serviced.
- Do not transport the scale with a patient or object on the scale.
- Do not wheel or pull the scale down stairs, doing so may damage internal parts.
- Ensure that the AC adapter and scale do not come in contact with liquids, excessive temperature, or excessive humidity.

## **Patient/caregiver safety**

- This scale is designed for static weighing of patients only. No scale should be used for patient transfer.
- Patient should wear socks or other form of lightweight foot covering during weighing event.
- To prevent patient injury, the patient must be attended to throughout the entire weighing event. Caregivers should ensure that the patient is stable and provide support as needed when getting onto and off of the scale.

## **When operating the scale with the AC adapter:**

- Operate this scale exclusively with the AC adapter provided by Health o meter Professional. Use of an unspecified adapter will void the warranty, and can pose a serious safety hazard.
- For use with AC adapter model ADPT31 (USA or Canada) or ADPT30 (International) (not included)
- Prior to using this scale, inspect the AC adapter cord for cracking / fraying, or for broken / bent plug prongs.
- Prior to using this scale, ensure that the AC adapter is plugged into an outlet with the rated voltage appropriate for operation.
- Ensure that the AC outlet is wired to a circuit breaker or other protected power source.
- Unplug the AC adapter, and carefully store both the adapter and adapter cord before moving the scale.
- Operating this scale at voltages and frequencies other than specified can damage the equipment and will void the warranty.

## **When operating the scale with batteries:**

- If the "LO" indicator activates, replace the batteries or switch to the AC adapter as soon as possible.
- When replacing / inserting batteries, be sure to use all new batteries.

This equipment has been tested and found to comply with the EMC limits for the Medical Device Directive 93/42/EEC (EN 55011 Class A and EN 60601-1-2). These limits are designed to provide reasonable protection against harmful interference in a typical medical installation. The equipment generates, uses and may radiate radio frequency energy and, if not installed and used in accordance with these instructions, may cause interference to other devices in the vicinity. There is no guarantee that interference will not occur in a particular installation. If this equipment does cause harmful interference with other devices, which can be determined by turning the equipment off and on, the user is encouraged to try to eliminate the interference by one or more of the following measures:

- Reorient or relocate the receiving device.
- Increase the separation between the equipment.
- Plug the equipment into an outlet on a circuit different from that to which the other device(s) is connected.
- Consult Customer Service or a field service technician for help.

**In no event whatsoever shall Pelstar, LLC be liable for damages or injuries arising from or connected with the assembly, use, or misuse of its products.**

# SPECIFICATIONS FOR THIS SCALE

## General

The model 498KL remote display digital scale uses highly sophisticated microprocessor technology. This precision scale is designed to provide accurate, reliable and repeatable weight measurements. In addition, each scale is designed to provide the user with features that make the weighing process simple, fast, and convenient.

Weight can be displayed in pounds (lb) or in kilograms (kg). For privacy and convenience in use, the scale features a remote display head which may be held by the operator, placed on a table or other flat surface, or mounted on a wall. **This scale can be powered using AC adapter (not included) or by 6 - AA batteries (included).**

## 498KL Scale Specifications

Capacity and Resolution	500 lb x 0.2 lb (220 kg x 0.1 kg)	
Power Requirements	Adapter Model No. UE15WCP1-090050SPA, Part No. UE160714HKKK1-P Adapter Model No. UES06WNCP-090050SPA, Part No. UE190716HKSH2RM Adapter Model No. / Part No. RHD10W090050 (Not Included) Input: 100-240VAC, 50/60Hz, 500mA Output: 9.0V $\overline{\overline{\overline{\quad}}}$ 0.5A  Or 6 AA Batteries (included)	
Environmental	Operating temperatures: 50°F to 104°F (10°C to 40°C) Storage temperatures: 32°F to 122°F (0°C to 50°C) Maximum Humidity: 95% RH	
Physical Dimensions	<b>Platform</b> Length: 16 1/2" (419 mm) Width: 13 3/4" (349 mm) Height: 2 3/8" (60 mm) Weight: 14 lb (6.35 kg)	<b>Display assembly</b> Length: 8" (204 mm) Width: 4 1/2" (117 mm) Height: 2" (49 mm) Weight: 1.2 lb (0.54 kg)

# DEFINITION OF SYMBOLS



Attention, Consult Accompanying Documents



Type B Applied Parts



AC to DC power supply

# CERTIFICATIONS / DISPOSAL

## Certification Descriptions

<p><b>ISO13485:2016 CERTIFIED</b></p> <p><b>ISO 9001:2015 CERTIFIED</b></p>	<p>Pelstar, LLC has been officially certified as the manufacturer of Health o meter® Professional medical devices. The Pelstar, LLC quality assurance system covers the development, production, sales and service of medical scales and measuring systems.</p>
<p> E112697 UL 60601-1 CSA C22.2 No. 601.1-M90</p>	<p>This product is tested to and meets the requirements of:</p> <ol style="list-style-type: none"><li>1. UL60601-1 First Edition: Safety for Medical Electrical Equipment</li><li>2. CSA C22.2 No. 601-1 M90: Medical Electrical Equipment</li></ol>

Health o meter® Professional scales are manufactured in FDA-registered factories.

## Scale Disposal



This Health o meter® Professional scale must be disposed of properly as electronic waste. Follow the national, regional or local regulations that apply to you for disposal of electronic waste or batteries. Do not dispose of this device in the domestic waste stream.

# 498KL ASSEMBLY INSTRUCTIONS

## **Before Assembly**

Each 498KL remote display digital scale is shipped disassembled in one carton. Carefully inspect the carton for shipping damage before unpacking. If damage is found, contact your shipper or a Health o meter® Professional representative immediately at 1-800-815-6615. Claims must be filed with the shipper as soon as possible after receipt of the package. The following information details what you will find inside the main carton as you unpack the parts for assembly.

To prevent scratching any components, carefully remove each assembly from the carton and unwrap the packing materials. Set the carton aside for storage. To avoid damaging the scale parts when unpacking, do not use a box cutter, knife, scissors, or any sharp object to open the protective inner packaging.

## **Parts List**

- (1) Scale platform
- (1) Display assembly
- (1) Display bracket
- (6) AA batteries
- (1) User instructions

## **Tools Required**

Phillips head screwdriver (not included)

# DISPLAY BRACKET ASSEMBLY INSTRUCTIONS

## Display Bracket Assembly

**Note:** Do not use display bracket for wall mount. Display bracket is for surface use only. For wall mounting, mount display assembly directly to the wall, see page 8.

1. Carefully remove the scale platform with the display assembly from the carton, and place the scale platform and display assembly on a flat, level, and dry surface.
2. Remove the display bracket from the carton.
3. Remove the two small screws from plate B.
4. While holding plate A, slide the tab of plate B up and under the center tab on the back of plate A.
5. Align plate A and plate B, and ensure that the screw holes are lined up.
6. Insert the two small screws into the front of plate A and through the holes in plate B.
7. Using a Phillips head screwdriver, tighten the screws to secure plate A to plate B.
8. Slide the two mounting studs on the display bracket into the two mounting holes in the back of the display assembly. The display bracket is now ready for use.

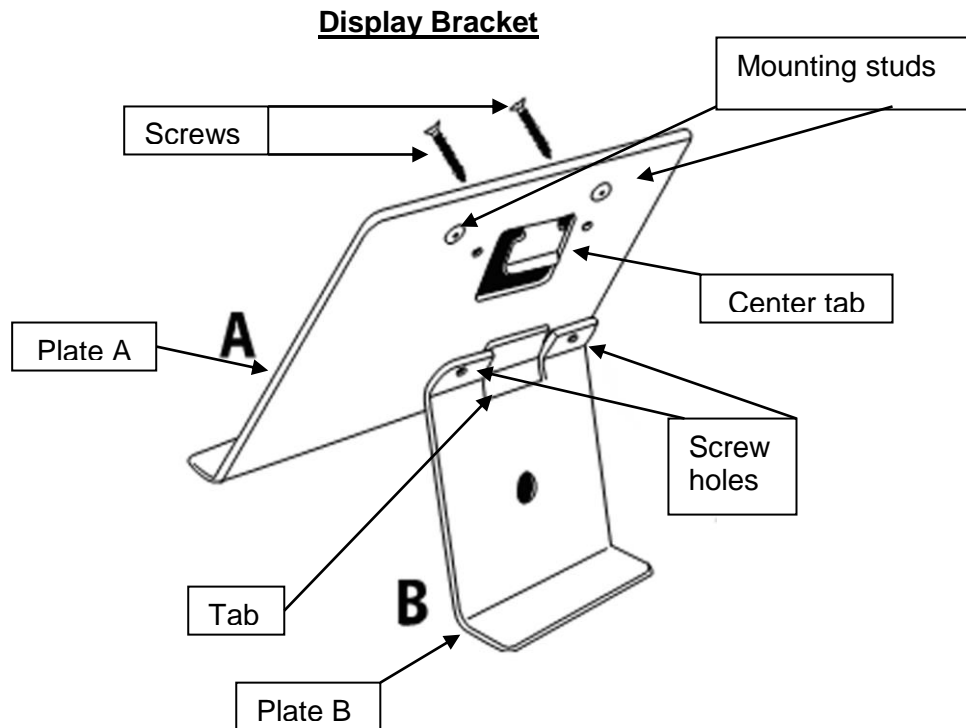

# DISPLAY WALL MOUNT INSTRUCTIONS

**Caution:** When wall mounting the display assembly, ensure that the mounting location is free of electrical lines, gas pipes, and other safety hazards. Ensure that wall is of construction that can support the display assembly.

**Note:** Remote head can be mounted to a wall up to 6 feet (1.83 m) from the base or it can be mounted on the display bracket (included) for placement on a table up to 6 feet (1.83 m) from the base.

**Note:** For wall mounting, mount display assembly directly to the wall. Do not use display bracket for wall mount. Display bracket is for surface use only.

## **Required Parts**

- (1) Display assembly
- (2) #8 Anchoring screws (4.2 mm nominal OD) (NOT INCLUDED)
- (2) Mounting anchors, compatible with wall construction (NOT INCLUDED)

1. Position the display assembly on the wall, and carefully trace around the display outline.
2. Mark a level horizontal line, 2.75" (70 mm) below the top of the display outline.
3. Mark a vertical line 3.1" (80 mm) from each side of the display outline.
4. Use the appropriate plastic or metal anchors for the type of wall construction.
5. At the horizontal and vertical intersections, carefully drill the appropriate sized holes.
6. Insert the anchors into the wall, and screw the two mounting screws into the anchors.  
Adjust the screw head depth such that the screw heads protrude 0.125" (3.2 mm) from the wall. **Warning: Extending the screw heads beyond 0.125" (3.2 mm) can damage the display assembly.**
7. Position the display assembly mounting holes onto the mounting screws and pull down on the display assembly to secure the bracket over the screws.

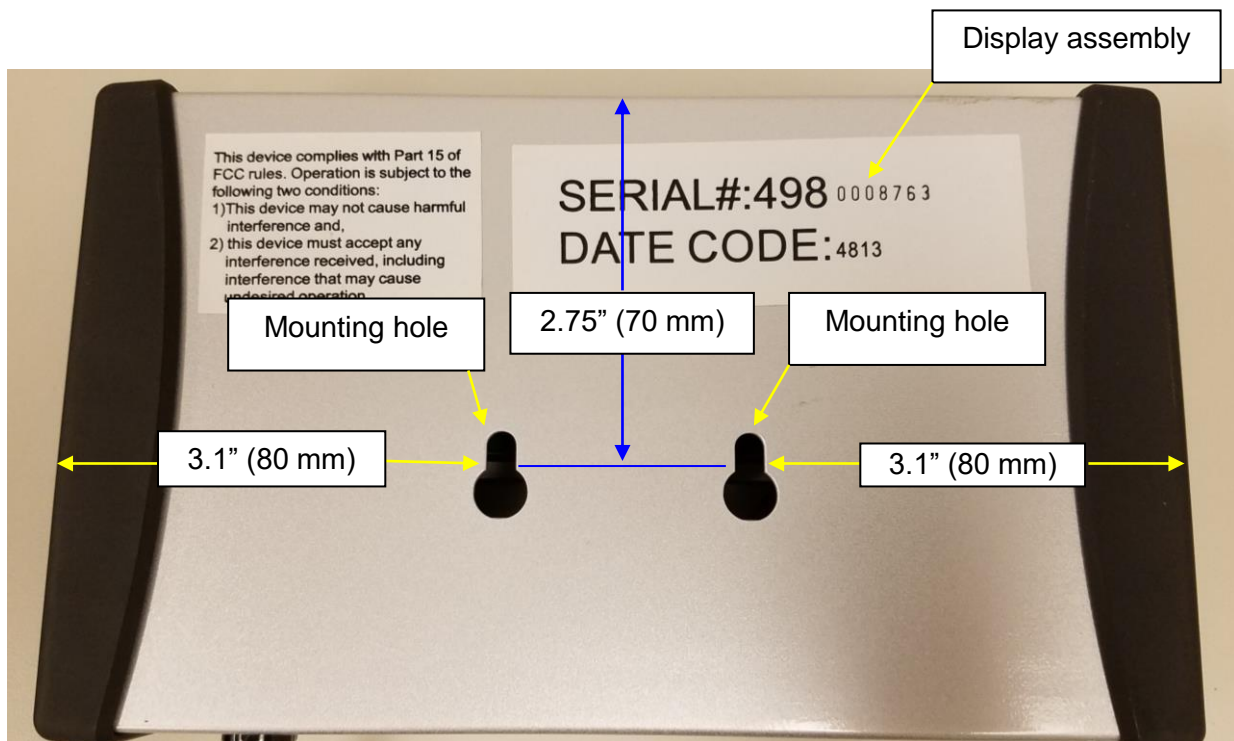



# POWERING THE SCALE

## **Powering the Scale / Inserting Batteries**

1. With a Phillips head screwdriver remove the battery cover on the side of the display assembly by unscrewing the (2) battery cover screws (see drawing below).
2. Replace or install 6 new AA batteries. Health o meter Professional recommends using alkaline or lithium batteries, rated for 130°F (54°C) operation. Do not use zinc-carbon batteries.
3. Re-attach the battery cover to the display assembly.
4. Ensure all objects are removed from the scale's platform, and then press the **ON/OFF** button to turn the scale on. The display will show "Start", then "0.0" LB or "0.0" KG. Press the **LB/KG** button to select the weight mode (LB or KG).

**Note:** The battery icon on the display does not indicate battery life. The battery icon is displayed when the scale is using batteries as the power source.

**Note:** This scale will always default to the settings and units last used (LB or KG).

**Note:** If the set up procedure fails, refer to the troubleshooting instructions. If the problem is not corrected, contact Health o meter Professional Scales Customer Service at 1-800-815-6615.

**Note:** If "Lo" appears on the display, it indicates that the battery power is low. It does NOT indicate a problem with the weight measurement.

**Warning:** If the scale will not be used for some time, remove the batteries to avoid a safety hazard. Disposal of batteries must be performed in accordance with the prevailing national, regional or local regulations that apply to you.

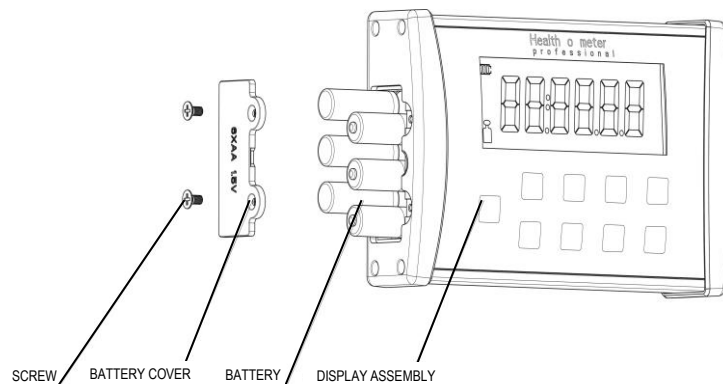

## **Optional AC Adapter**

1. Connect the optional AC adapter (not included) into the adapter jack on the scale platform.

**Warning:** To avoid a safety hazard, use only a Health o meter® Professional AC adapter.



2. Plug the scale's AC adapter into the power source.
3. When the AC adapter is disconnected from the scale, the scale will switch to battery power if batteries are installed.

**Caution:** Always plug the AC adapter into the scale first, then into the power source/wall outlet.

# SET UP INSTRUCTIONS

## Auto-Off Function

As an energy saving feature, the scale will automatically turn off after 2 minutes of inactivity. By default, this function is enabled.

## Disable Auto-Off

1. While the scale is turned off, press and hold the **HOLD/RELEASE** button.
2. While holding the **HOLD/RELEASE** button, press the **ON/OFF** button to turn the scale on.
3. "START" will briefly appear on the display followed by "AOF=0".
4. Auto-off is now disabled and the scale will remain on until the scale is manually turned off.

## Enable Auto-Off

1. While the scale is turned off, press and hold the **HOLD/RELEASE** button.
2. While holding the **HOLD/RELEASE** button, press the **ON/OFF** button to turn the scale on.
3. "START" will briefly appear on the display followed by "AOF=1".
4. Auto-off is now enabled.

## To Change Weight Measuring Unit (LB to KG/KG to LB):

**Note:** LB (Pounds) is the default weight measuring unit upon initial set-up/assembly.

1. Press the **ON/OFF** button to turn the scale on.
2. Wait for "0.0" LB or "0.0" KG to appear on the display.
3. Press the **LB/KG** button until the desired unit of measure is displayed.
4. Release the **LB/KG** button and the scale will operate in the selected mode.
5. Repeat steps 3-4 to change the weighing mode to a different unit of measure.

## LB/KG Lock Out

The weight measuring unit can be locked to only measure in KG or LB.

## KG Lock Instructions

1. Press the **ON/OFF** button to turn the scale on. Wait for "0.0" to appear on the display.
2. Press and hold the **LB/KG** button so that KG icon is displayed and continue holding the **LB/KG** button for approximately 10 seconds.
3. When the KG icon flashes, release the **LB/KG** button. The KG weight measuring unit is now locked and will remain locked even if the scale is turned off.

## LB Lock Instructions

**Note:** To lock in LB weight mode, you must follow the instructions above to lock in KG weight mode first.

1. Once the scale is locked in KG mode, press and hold the **LB/KG** button for approximately 10 seconds until the LB icon flashes.
2. When the LB icon flashes, release the **LB/KG** button. The LB weight measuring unit is now locked and will remain locked even if the scale is turned off.

## Disabling LB/KG Lock Out

**Note:** If your scale is locked in KG mode, you must first follow the instructions above to lock into LB mode, and then begin the disabling instructions below.

1. Press the **ON/OFF** button to turn the scale on. Wait for "0.0" to appear on the display.
2. Press and hold the **LB/KG** button until LB and KG icons *both* flash on the display. When both LB and KG icons are flashing, release the **LB/KG** button. The weight measuring unit is now unlocked; pressing the **LB/KG** button will allow user to toggle between LB and KG.

# OPERATING INSTRUCTIONS

## Keypad



Function	Description
<b>ON/OFF</b>	Turns scale on and off.
<b>ZERO</b>	Tares the scale prior to a weighing.
<b>HOLD/RELEASE</b>	Holds the weight value of the patient on the display until the button is pressed again to clear the value.
<b>BMI</b>	Prompts entry of height data to calculate patient's Body Mass Index (BMI).
<b>LB/KG</b>	Toggles between pounds (LB) and kilograms (KG).
<b>CLEAR</b>	Clears the incorrect height input when in BMI mode.
<b>UP ▲</b>	Increases height input (0.5 in / 0.5 cm increments)
<b>DOWN ▼</b>	Decreases height input (0.5 in / 0.5 cm increments)
<b>ENTER</b>	Accepts height value in BMI mode.

# OPERATING INSTRUCTIONS (CONT)

## Weighing a Patient

**Note:** When this scale is turned on, it will always default to the settings and units last used (LB or KG).

1. With all weight off the scale, press the **ON/OFF** button to turn on the scale.
2. “StArt” will briefly appear on the display, followed by “0.0” LB or “0.0” KG.



3. Assist the patient onto the scale. The scale will begin to display weight information. When a stable weight is determined, “LOCK” will appear along with the patient’s weight. Depending on the movement of the patient on the scale, it may take several seconds for the scale to lock onto the weight.

**Caution: To prevent patient injury, the patient must be attended throughout the entire weighing event.**

4. The weight may be held on the display by pressing the **HOLD/RELEASE** button. To release, press the **HOLD/RELEASE** button again.
5. After the weight measurement has been taken, have the patient step off the scale.
6. Press the **ON/OFF** button to turn the scale off.

## Zero Function

Zeroes the scale prior to a weight measurement. The **ZERO** button is also used in the Tare function outlined below.

## Tare Function

When using this scale, the weight of an object, such as a portable oxygen tank, can be subtracted from the total weight in order to determine the weight of the patient alone.

1. With all weight off the scale, press the **ON/OFF** button to turn on the scale.
2. “StArt” will briefly appear on the display, followed by “0.0” LB or “0.0” KG.
3. Place the object on the scale. The display will show a value for the object’s weight. The minimum weight that can be tared is 5 lb / 2.27 kg. Note: The scale must lock onto a weight before it can be tared.
4. Press the **ZERO** button. The word “TARE” will appear on the display, followed by “0.0” LB or “0.0” KG.
5. Keep the object on the platform, and have the patient step onto the scale. The scale will automatically deduct the weight of the object and only display the patient’s weight.
6. When you remove the item from the platform, “under” will be temporarily displayed and then the display will return to “0.0” LB or KG.

## OPERATING INSTRUCTIONS (CONT)

### **BMI Function**

Body Mass Index (BMI) is a ratio between a person's weight and height and interpreted as a BMI score. This BMI score is then used as a tool to categorize a patient as underweight, normal, overweight, obese or morbidly obese.

**Note:** The scale will not calculate BMI for a patient that is 24 pounds (12 kg) or less.

**Note:** If a height is not entered for the patient within 30 seconds of pressing the **BMI** button, the scale will return to the normal weighing mode.

1. With all weight off the scale, press the **ON/OFF** button to turn on the scale.
2. "StArt" will briefly appear on the display, followed by "0.0" LB or "0.0" KG.
3. Assist the patient onto the scale. The scale will begin to display weight information. When a stable weight is determined, "LOCK" will appear along with the patient's weight. Depending on the movement of the patient on the scale, it may take several seconds for the scale to lock onto the weight.
4. After obtaining the patient's weight and the patient remaining on the scale, press the **BMI** button.
5. The display will show 65.0" (in LB mode) or 150.0 cm (in KG mode). Use the keypad ▲ and ▼ buttons to enter the patient's height in inches if weighing in LB or centimeters if weighing in KG.
6. Once height is keyed in, press the **ENTER** button.
7. The display will show the patient's BMI.
8. Press the **CLEAR** button to return to the weighing mode.

## TRANSPORT

This scale can be easily placed into an optional carrying case for storage or transport from one location to another. This scale does not include the carrying case item # 64771, which may be acquired separately. To prepare the scale for transport, follow these steps:

1. Remove the display assembly and display bracket from their current position, if used.
2. Unplug the AC adapter and load cell cable from the scale platform, and remove the AC adapter from the outlet, if used.
3. Carefully store the AC adapter, display bracket, and display assembly in the carrying case to prevent damage during transport.
4. Lift scale platform carefully and place it into the carrying case. Position scale platform with the adaptor jack and load cell cable port facing up.
5. Close carrying case flap over the scale.
6. Grasp the carrying case strap and lift carefully into the upright position. Position the strap over a shoulder. The scale can now be transported.



**Optional Carrying Case (Item #64771)**

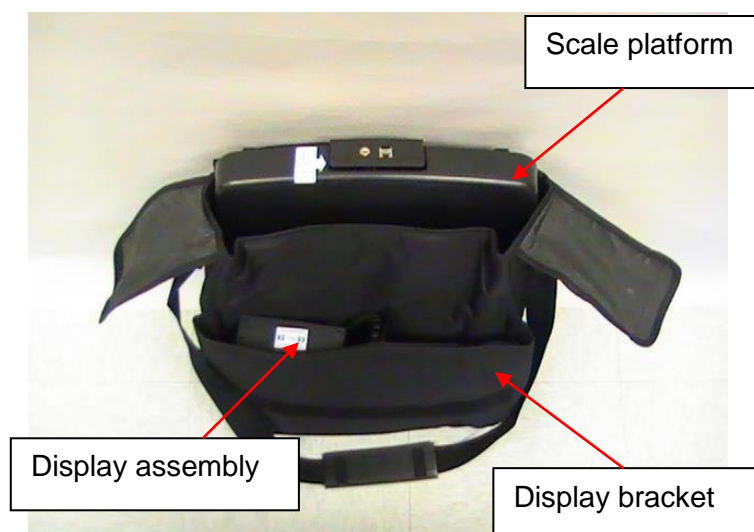

# MAINTENANCE

## **Maintenance**

The following pages provide instructions for maintenance, cleaning, calibration, and troubleshooting for the 498KL scale. Maintenance operations other than those described in this manual should be performed by qualified service personnel.

**Caution: Before first use, or after long periods of non-use, check the scale for proper operation and function. If the scale does not operate correctly, refer to qualified service personnel.**

1. Check overall appearance of the total scale for any obvious damage, wear, and tear.
2. Inspect the AC adapter cord for cracking or fraying, or for broken/bent prongs.

**Note:** This scale is an extremely sensitive weighing device. Items such as clothing or towels placed or dropped on the scale may cause a scale to activate. In order to prevent battery depletion, do not store or leave anything on the scale.

## **Cleaning and Disinfecting**

Proper care and cleaning is essential to ensure a long life of accurate and effective weighing.

1. Health o meter® Professional recommends using one of the following solutions on a soft cloth or disposable wipe:
  - mild soap and water solution
  - 70% isopropyl alcohol
  - solution with 1-5% hydrogen peroxide concentrationAfter cleaning/disinfecting, wipe with a cloth dampened with water and then with a clean dry cloth. To avoid residue build-up or damp surfaces, ensure all scale parts are completely dry after cleaning.
2. Never use rough or abrasive materials to clean the scale, as these will damage the scale's finish.
3. Do not submerge the scale in water or any other liquid.
4. Do not pour or spray fluids directly on the scale.

## **Replacement Parts**

Parts may be available if a piece of the scale needs to be replaced. Contact Health o meter Professional Scales Customer Service at 1-800-815-6615 to inquire about the availability of these replacement parts.

<b>Part #</b>	<b>Description</b>
500KLFOOT	Foot for base
500KLMAT	Replacement mat for platform
ADPT30	Power adapter (International)
ADPT31	Power adapter (US and Canada)
BATTDOORLSERIES	Battery door

# CALIBRATION

## Calibration

**This scale has been factory calibrated, and does not require calibration prior to use.** If required, the scale can be calibrated. Calibration of your 498KL scale is performed using kilograms (KG) or pounds (LB), according to the unit of measure used upon entering into the calibration path. When calibrating in pounds, a total of 300 lbs is required, applied in increments of 100 lb, 200 lb and 300 lb. If calibrating in kilograms, a total of 120 kg is required, applied in increments of 40 kg, 80 kg and 120 kg.

**Note: Only weights certified and traceable to national standards are to be used for calibration procedures.**

ACTION	DISPLAY SHOWS
Pressing and holding the <b>LB/KG</b> and <b>ZERO</b> buttons at the same time, press the <b>ON/OFF</b> button to turn on the scale. Release all three buttons when "CAL" appears on the display. Numbers will appear indicating that you can begin calibration.	"CAL" followed by numbers
When calibration numbers stabilize, press the <b>ZERO</b> button. "C-100" (for LB mode) or "C-40" (for KG mode) will flash on the display, followed by "0".	Numbers followed by "C-100" (LB mode) or "C-40" (KG mode) then "0" or "1".
Place 100 lb or 40 kg on the scale. Numbers will appear on the display. When calibration numbers stabilize, press the <b>ZERO</b> button. "C-200" (for LB mode) or "C-80" (for KG mode) will appear on the display, followed by "0" or "1".	Numbers followed by "C-200" (LB mode) or "C-80" (KG mode) then "0" or "1".
Place an additional 100 lbs or 40 kg on the scale, for a total of 200 lbs or 80 kg. Numbers will appear on the display. When calibration numbers stabilize, press the <b>ZERO</b> button. "C-300" (for LB mode) or "C-120" (for KG mode) will appear on the display, followed by "0" or "1".	Numbers followed by "C-300" (LB mode) or "C-120" (KG mode) then "0" or "1".
Place an additional 100 lbs or 40 kg on the scale, for a total of 300 lbs or 120 kg. Numbers will appear on the display. When calibration numbers stabilize, press the <b>ZERO</b> button. "END" will appear on the display, followed by "OFF". The scale will automatically shut off.	"XXXXX" followed by "END" then "OFF"



# TROUBLESHOOTING

## Troubleshooting

Before contacting service personnel, refer to the following instructions to check and correct any failures.

<b>Symptom</b>	<b>Possible Cause</b>	<b>Corrective Action</b>
Scale does not turn on	<ol style="list-style-type: none"> <li>1. Dead battery</li> <li>2. Faulty electrical outlet</li> <li>3. Bad power supply</li> </ol>	<ol style="list-style-type: none"> <li>1. Replace batteries</li> <li>2. Use a different outlet</li> <li>3. Replace AC adapter</li> </ol>
Questionable weight or the scale does not zero	<ol style="list-style-type: none"> <li>1. External object interfering with the scale</li> <li>2. The display did not show "0.0" before weighing</li> <li>3. Scale is not placed on a level floor</li> <li>4. Scale is out of calibration</li> </ol>	<ol style="list-style-type: none"> <li>1. Remove interfering object from the scale</li> <li>2. Ask the patient to get off the scale, zero the scale and begin weighing process again</li> <li>3. Place the scale on a level floor and begin weighing process again</li> <li>4. Check weight with known weight value</li> </ol>
Weighing is performed but the weighing process takes too long and the weight does not lock on the displayed	The patient is not standing still	Ask the patient to stand still
The display shows "Over" message	The load on the scale exceeds the capacity (500 lb / 220 kg)	Remove the excess weight and use the scale according to its limits
The display shows "Lo" message	The batteries are depleted	Replace batteries according to instructions

# WARRANTY

## Limited Warranty

### What does the Warranty Cover?

This Health o meter® Professional scale is warranted from date of purchase against defects of materials or in workmanship for a period of two (2) years. If product fails to function properly, return the product, freight prepaid and properly packed to Pelstar, LLC (see "To Get Warranty Service", below, for instructions). If the manufacturer determines that a defect of material or in workmanship exists, the customer's sole remedy will be replacement of the scale at no charge. Replacement will be made with a new or remanufactured product or component. If the product is no longer available, replacement may be made with a similar product of equal or greater value. All replaced parts are covered only for the original warranty period.

### Who is Covered?

The original purchaser of the product must have proof of purchase to receive warranty service. Please save your invoice or receipt. Pelstar dealers or retail stores selling Pelstar products do not have the right to alter, or modify or any way change the terms and conditions of this warranty.

### What is Excluded?

**Your warranty does not cover normal wear of parts or damage resulting from any of the following:** negligent use or misuse of the product, use on improper voltage or current, use contrary to the operating instructions, abuse including tampering, damage in transit, or unauthorized repair or alternations. Further, the warranty does not cover natural disasters, such as fire, flood, hurricanes and tornadoes. This warranty gives you specific legal rights, and you may also have other rights that vary from country to country, state to state, province to province or jurisdiction to jurisdiction.

**To get Warranty Service make sure you keep your sales receipt or document showing proof of purchase.** Call (+1) 800-638-3722 or (+1) 708-377-0600 to receive a return authorization (RA) number, which must be included on the return label. Attach your proof of purchase to your defective product along with your name, address, daytime telephone number and description of the problem. Carefully package the product and send with shipping and insurance prepaid to:

Pelstar, LLC  
Attention R/A# \_\_\_\_\_  
Return Department  
9500 W. 55<sup>th</sup> St.  
McCook, IL 60525

### Extended Warranty Available\*

This scale is eligible for Health o meter® Professional ScaleSurance® Extended Warranty Program. ScaleSurance® extends the warranty period for an additional two years. This extension to the standard Limited Warranty can be purchased with new scales or for a facility's existing scale before its current warranty has expired. To learn more, visit [www.homscales.com/scalesurance/](http://www.homscales.com/scalesurance/) or contact your medical supply distributor.

\*Not available in all countries



**PELSTAR, LLC**

**9500 West 55th St. McCook, IL 60525-7110 USA**

**1-800-638-3722 or 1-708-377-0600**

PLEASE REGISTER YOUR SCALE FOR WARRANTY COVERAGE AT:

[www.homscales.com](http://www.homscales.com)

Health o meter® is a registered trademark of Sunbeam Products, Inc. used under license.

Health o meter® Professional products are manufactured, designed, and owned by Pelstar, LLC.

We reserve the right to improve, enhance, or modify Health o meter® Professional product features or specifications without notice.

© Pelstar, LLC 2021