



Installation and operating instructions 18 **ENG**



D^{med}® **VISIANO 20**

Examination light

Contents

1	SAFETY INSTRUCTIONS	18
1.1	Intended use.....	18
1.2	User profiles.....	18
1.3	Safety instructions.....	18
1.4	Warning levels	18
1.5	Specific mounting instructions	18
2	SCOPE OF SUPPLY	19
2.1	VISIANO 20-2 C T1	19
2.2	VISIANO 20-2 P TX.....	19
3	ASSEMBLY of VISIANO 20-2 C T1	19
3.1	Load data.....	19
3.2	Attaching the ceiling bracket	19
3.3	Assemble the light on ceiling tube	21
4	ASSEMBLY of VISIANO 20-2 P TX.....	21
4.1	Load data.....	21
4.2	Assembly.....	21
5	OPERATION	21
5.1	VISIANO 20-2 C T1	21
5.2	VISIANO 20-2 C T1 VISIANO 20-2 P TX	21
5.3	Transport position	22
6	DISINFECTION CLEANING	22
7	SAFETY INSPECTIONS	23
8	DISMANTLING	23
8.1	Disposal.....	23
9	ACCESSORIES.....	23
10	ADDITIONAL INSTRUCTIONS.....	23
11	TROUBLESHOOTING	24
12	TECHNICAL DATA.....	24
13	ELECTROMAGNETIC COMPATIBILITY (EMC).....	26

1 SAFETY INSTRUCTIONS

1.1 Intended use

The light D^{med}® VISIANO is an examination light. Its intended use is to illuminate the body of the patient to support diagnosis or treatment. An interruption of the diagnosis or treatment caused by a light failure is always possible without posing any risk for the patient. The light cannot be used in operating rooms.

1.2 User profiles

Medical professional

A medical professional is any person who has completed medical training and is working in his or her professional field.

Cleaning professional

A cleaning professional is trained in national and job-related hygiene regulations.

Electrician

An electrician is trained in the fields of electronics and electrical engineering and is familiar with the relevant standards and regulations.

Qualified professional



A qualified professional is capable of mounting and dismantling the light thanks to professional training, knowledge and experience and knowledge of the regulations.

1.3 Safety instructions

- ▶ Operation by a medical professional
- ▶ The instructions form part of the product. They must be stored and made accessible to all subsequent users.
- ▶ Any work on the light (including repairs) must be carried out by qualified electricians only. Mounting must be performed by a qualified professional only.
- ▶ The light must not be altered or manipulated in any way. Only approved original parts must be used. Any use other than the intended use with original parts may give rise to other technical values and life-threatening danger.
- ▶ Operation in potentially explosive areas is prohibited. The light power supply is a potential ignition source.
- ▶ The light must only be operated in dry, dust-free rooms.
- ▶ The light must not be left switched on without supervision.
- ▶ For lights in protection class I, it is essential for the earthing conductor to be connected to the light housing.
- ▶ Do not use any light that is damaged. Defective cables are also potential hazards. Do not place the cable close to any heat source or on sharp edges.
- ▶ Damage to the eyes. Never look directly into the light source.
- ▶ Replace any glass that is damaged before operating the light again.
- ▶ In order to prevent electric shocks, only connect the light to a power supply with an earth conductor (only C-version).
- ▶ Luminaires which are equipped with a hospital grade plug (UL 817, only US- and Canada version), the earth connector is used as a functional earth within the luminaire.

- ▶ Never place additional loads on the light head or the arm.
- ▶ The light must not be covered by a cloth or any similar item while it is in operation.
- ▶ The ventilation openings (where they exist) must be free whenever the light is in operation.
- ▶ The light must not be operated near to external heat sources that exceed the maximum ambient temperature of the light.
- ▶ The light must not be used in environmental conditions other than those for which it is intended.
- ▶ The light must only be used for the intended use described in this document.
- ▶ The manufacturer cannot be held responsible for any injury or damage that is caused as a result of any use other than the intended use or of any failure to comply with safety instructions and warnings.

1.4 Warning levels

 DANGER
Indication of hazards that can lead to death or serious injury if measures are disregarded.
 WARNING
Indication of hazards that can lead to injury if measures are disregarded.
CAUTION
Indication of hazards that can lead to damage to property if measures are disregarded.

1.5 Specific mounting instructions

VISIANO 20-2 C T1

- ▶ **Mounting material is not included.**
- ▶ The ceiling mounting must only be fixed to ceilings that have a concrete stability class B25 (C20/25) or higher.
- ▶ Solid ceiling reinforcement parts must not come into contact with the ceiling mounting. If there is any doubt, an authorized professional must confirm that mounting is possible on the mounting base being used.
- ▶ Drilling must be done by specialists in compliance with the drilling tolerances for the reinforcement anchor that have been approved by the manufacturer.
- ▶ Screws must be tightened carefully using a torque key that complies with the instructions of the reinforcement anchor manufacturer.

VISIANO 20-2 P TX

- ▶ **Mounting material is not included.**
- ▶ When using the accessory "wall mount", the installation must be undertaken by a professional.
- ▶ The wall must guarantee a firm hold.
- ▶ Use only mounting material which is suitable for the corresponding substrate.

2 SCOPE OF SUPPLY

2.1 VISIANO 20-2 C T1

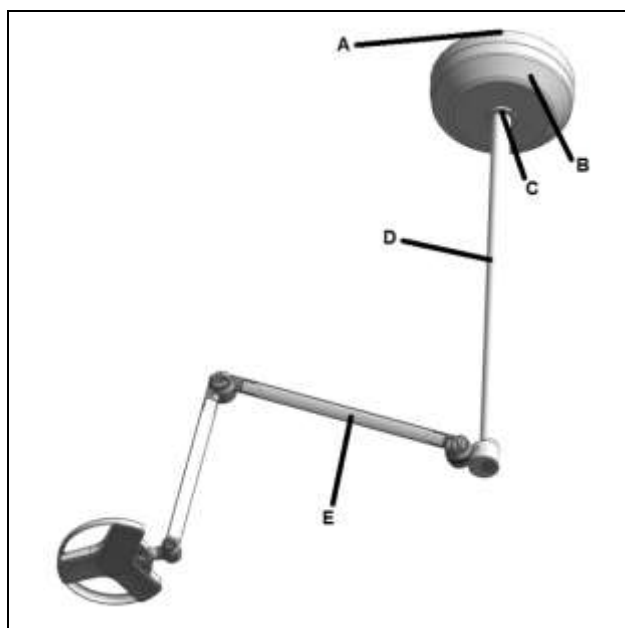

- A: 1x **ceiling bracket (inner surface of B)**
 B: 1x **ceiling cover**
 C: 1x **end ring**
 D: 1x **ceiling tube incl. cable**
 E: 1x **light with adaptor (pre-assembled)**

2.2 VISIANO 20-2 P TX



- ▶ 1x **light**
- ▶ 1x **power cable**

3 ASSEMBLY of VISIANO 20-2 C T1

3.1 Load data

Bending moment M_B	25Nm
Vertical weight F_G	90N

3.2 Attaching the ceiling bracket

⚠ DANGER

Assembly by qualified personnel

- ▶ Assembly must be carried out by qualified personnel only. Lack of appropriate knowledge could be life-threatening.

⚠ DANGER

Life-threatening danger from falling light.

- ▶ The ceiling must be made of solid concrete to guarantee a secure hold.

⚠ DANGER

Electric shocks are life threatening

- ▶ It must be possible to separate the light from the mains by an external all-pole switch (not included).

⚠ DANGER

Electric shocks are life-threatening

- ▶ Voltage supply from the power connection must be protected on all poles by means of an overcurrent release (according to national installation requirements; it is not included in the scope of supply).

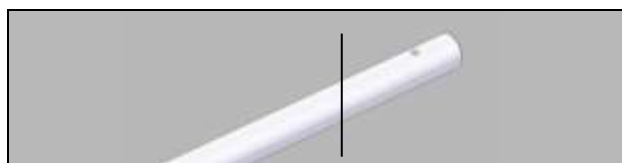

- ▶ Pay attention to the minimum distance of the ceiling tube!
- ▶ Saw ceiling tube to the desired length at the top end using a metal saw and deburr.



- ▶ Remove fastening screw.

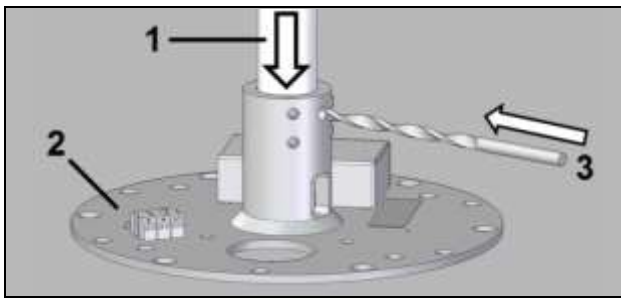

- ▶ Insert ceiling tube **1** into ceiling bracket **2** and drill with $d=9\text{mm}$ **3**. Use the existing hole in the ceiling bearing as a guide.

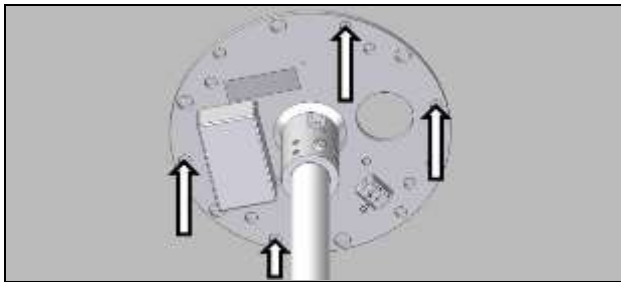

- ▶ Make 4 opposed drill hole markings ($\text{Ø}13\text{mm}$), note the position of the $\text{Ø}60\text{mm}$ drill hole for electrical connections

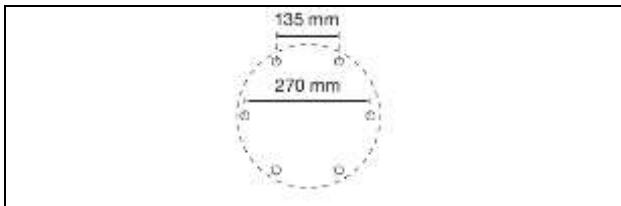

- ▶ Check clearances

⚠ DANGER

Risk of injury from falling parts

- ▶ The ceiling bracket must be secured to the fastening material, which must be suitable for the corresponding ceiling condition.

⚠ DANGER

Risk of injury from falling parts

- ▶ Mounting must be performed by two people.

CAUTION

Use protective equipment in line with the tool manufacturer's instructions

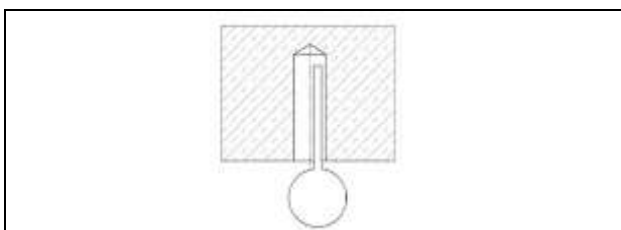

- ▶ Drill the bore holes, then blow them out using bellows

⚠ DANGER

Risk of injury from falling light

- ▶ The ceiling must be made of solid concrete to guarantee a secure hold.
- ▶ Use suitable ceiling anchors.



- ▶ Disassemble the securing element from the ceiling tube (Allen wrench is enclosed; do not lose the threaded pin!)



- ▶ Insert the cable (with loose ends first) and pull up to the stop

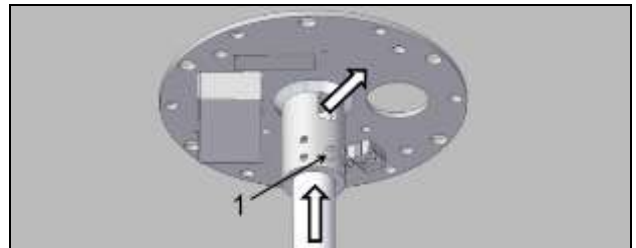

- ▶ Pull the light cable of the ceiling tube through the light mount.
- ▶ Insert ceiling tube into light mount
- ▶ Secure using the M8 safety screw and nut **1**



- ▶ Hold the ceiling bracket against the ceiling and strike the ceiling anchor with a hammer
- ▶ Tighten fastening in line with manufacturer's data

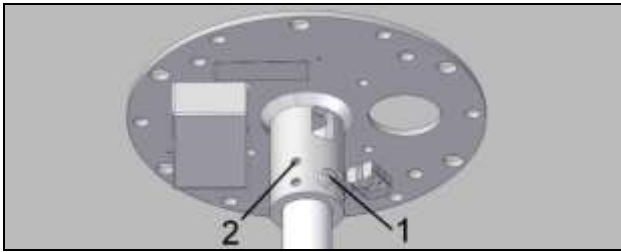

- ▶ Tighten M8 safety screw and nut **1** (20 Nm / 14.75 lbf ft)
- ▶ Tighten all 4 threaded pins **2** (5 Nm / 3.68 lbf ft)

⚠ DANGER

Mortal danger from electric shock

- ▶ Disconnect from the power supply and secure against unintended switching on before starting work on the power connection.

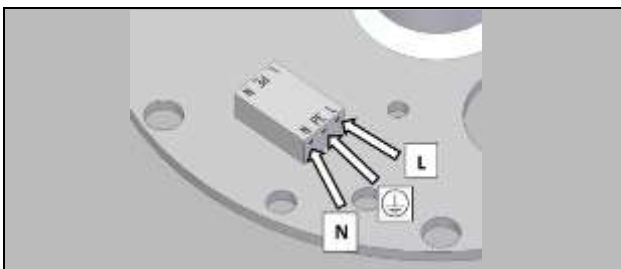

- ▶ Make power connection



- ▶ Connect the secondary cable to the connection point
- ▶ Pay attention to the polarity:
 - + = red** → **Connect the brown cable**
 - = blue** → **Connect the blue cable**



- ▶ Push cover and end ring over the ceiling bracket and tighten them (0.5Nm)

3.3 Assemble the light on ceiling tube

⚠ WARNING

The light will fall if fastening is done incorrectly

- ▶ The securing element must be screwed in fully and correctly.

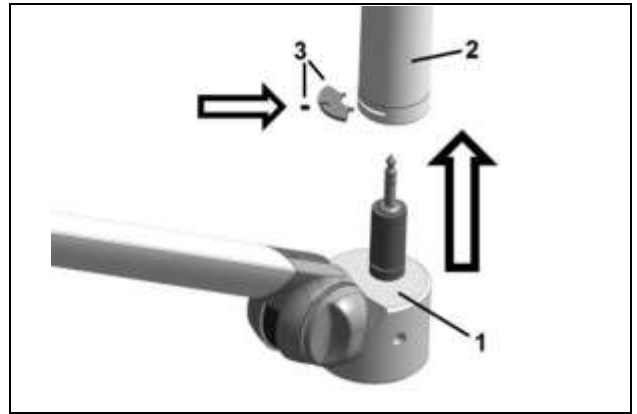

- ▶ Insert the light and the adapter **1** into the ceiling tube **2**
- ▶ Insert securing element with threaded pin **3** and screw in to the stop
- ▶ Loosen by one quarter-turn to ensure the operation of the turnover axis

4 ASSEMBLY of VISIANO 20-2 P TX

4.1 Load data

Bending moment M_B	25Nm
Vertical weight F_G	20N

4.2 Assembly

- ▶ The lights are equipped with an adapter pin. The light must be positioned in one of the accessories described in chapter 9.

5 OPERATION

5.1 VISIANO 20-2 C T1

⚠ DANGER

Electric shocks are life-threatening

- ▶ Only connect to a mains power supply with a protective conductor

5.2 VISIANO 20-2 C T1 VISIANO 20-2 P TX

⚠ DANGER

Electric shocks are life-threatening

- ▶ Do not insert any power cable that is damaged.
- ▶ If there is any sign of damage to the power cable, replace it immediately with a new one.
- ▶ The connection voltage and frequency must match the data on the type plate.

⚠ WARNING

Risk of eye damage

- ▶ Never look directly into the beam of light.

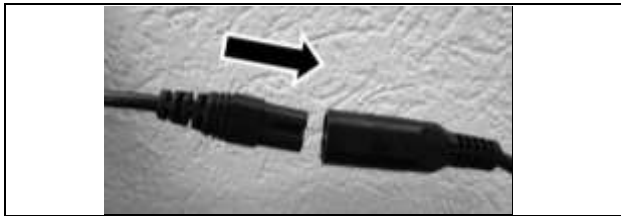

- ▶ Insert power cable
- ▶ Connect the cable to the mains
- ▶ Perform a function test before every use: All LED's in the light cone must illuminate.

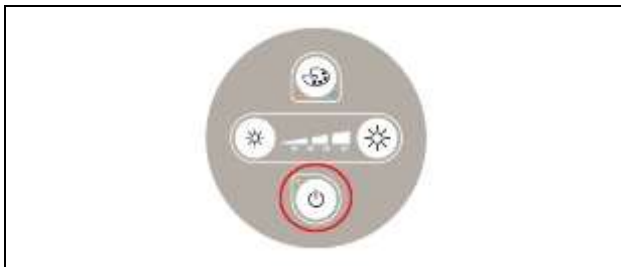

- ▶ Switch the LED module on/off



- ▶ Set the desired colour temperature according to the following table:

COLOUR	COL. TEMP.	RECOMMENDATION
blue	cold white	Ideal for identifying individual vessels for wound follow-up treatment and small procedures
orange	warm white	Ideal for various types of skin examinations

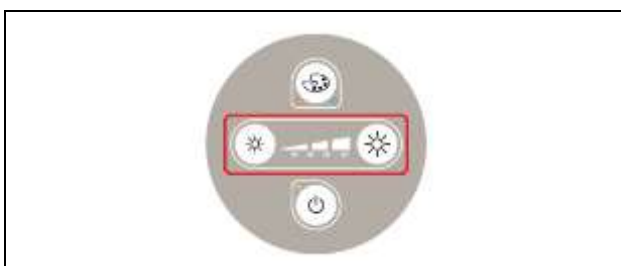

- ▶ Set the desired Illuminance in 25% dimmer steps

5.3 Transport position



- ▶ Only transport the light in this position.

6 DISINFECTION CLEANING

⚠ DANGER

Electric shocks are life-threatening

- ▶ Switch off the power and secure against unintended switching on before disinfectant cleaning.

CAUTION

Damage to property caused by incorrect cleaning

- ▶ Use only disinfectants that will not affect the functional capability of the light.
- ▶ No cleaning agents containing solvents, chlorine or abrasive products must be used. Those agents can cause damage to the plastic parts.
- ▶ The cleaning and disinfection agents must be suitable and approved for plastics like PC, PMMA, PA and ABS.
- ▶ Concentrated disinfectants may damage the light.
- ▶ Pay attention to the specifications from the data sheet of the agent for concentration and effectiveness time.
- ▶ Unsuitable cloths can cause scratches.

CAUTION

Dirt decreases luminosity

- ▶ Clean regularly to keep the screen clean.
- ▶ Disinfection only by wiping is permitted.



- ▶ Clean the PA screen with a non-abrasive cleaning cloth and a suitable cleaning agent.

CAUTION

To minimize the risk of disease transmission, in addition to complying with this instruction for use, you must also comply with the applicable occupational health and safety regulations and the requirements of national bodies with responsibilities for hygiene and disinfection.

7 SAFETY INSPECTIONS

⚠ DANGER

Electric shocks are life-threatening

- ▶ Remove the mains plug from the mains.
- ▶ The connecting cable must be checked for damage at least once per year.

CAUTION

- ▶ Maintenance and repairs must only be carried out by qualified electricians.
- ▶ The corresponding user profile is described in Chapter 1, Safety instructions

8 DISMANTLING

⚠ DANGER

Electric shocks are life-threatening

- ▶ Disconnect from the power supply and secure against unintended switching on before disassembling.

8.1 Disposal

Do not dispose of the light in household refuse. Dispose of the light at a disposal point in accordance with local regulations or take them to a dealer that provides an appropriate disposal service. Cut off the cable directly on the housing.



The products listed above are more than 95% recyclable. The lights have been constructed to be compatible with recycling so that a high proportion of the materials used in these products can be recycled or converted into energy after their end of service life. They contain no materials that are dangerous or that need to be monitored.

9 ACCESSORIES

Table clamp (Art. No.: D14.228.000 - black)



Universal mount (Art. No.: D13.430.000 - pure white)



Rail clamp (Art. No.: D13.269.000)



Wall bracket (Art. No.: D13.231.000 - pure white)



Roller stand (Art. No.: D14.022.000)



10 ADDITIONAL INSTRUCTIONS

The light itself is maintenance-free.

You can obtain additional documents about this product from the manufacturer upon request.

These lights do not affect any other devices.

To save energy, the light should only be switched on when actually needed.

11 TROUBLESHOOTING

Fault	Possible cause	Troubleshooting	User profiles
The light does not light	Contact problem	Switch on again	All
The light does not light	No mains voltage	Check mains voltage, check all connections	Electrician
The light does not light	LED module defective	Contact manufacturer service	By manufacturer service only

12 TECHNICAL DATA

Electrical data:

Rated input voltage	100 - 240VAC
Frequency range	50/60 Hz
Power consumption	21-25VA (21W)
Input current	0.1-0.22A
Power factor	0.88-0.99
Power supply secondary side	24VDC

Photometric values:

Central illuminance E_c at 0.5m (1.64 feet) distance	60'000 lx *
Light field diameter d_{10} at 0.5m (1.64 feet) distance	$\varnothing = 21 \text{ cm (8.3")} *$
Light field diameter d_{50} at 0.5m (1.64 feet) distance	$\varnothing = 12 \text{ cm (4.7")} *$
Colour temperature	4500K / 3500K *
Colour rendering index R_a	>95
Colour rendering index R_9	>90
Total irradiance E_e at maximum intensity	<240 W/m ²
Ratio irradiance E_e to illuminance E_c	4 mW/m ² /lx
	* -10% / +20% tolerance

Ambient conditions for transport, storage and operation:

Ambient temperature (storage and transport)	-20°C to +70°C (-4°F to +158°F)
Ambient temperature (operation)	+10°C to +35°C (+50°F to +95°F)
Relative humidity (non-condensing) (storage and transport)	max. 90%
Relative humidity (non-condensing) (operation)	max. 75%

Weight:

Light head	0.6kg (1.3 lb)
VISIANO 20-2 C T1	9kg (19.8 lb)
VISIANO 20-2 P TX	2kg (4.4 lb)

Mode of operation:

Mode of operation	Continuous operation
-------------------	----------------------

Classification:	
VISIANO 20-2 C T1	Protection class I (C-version)
VISIANO 20-2 P TX	Protection class II (P-version)
Degree of protection according to IEC 60529	IP 20
Classification according to directive 93/42/EEG – annex IX (medical device class)	Class I
U.S. FDA Device Class	Class I
Electrical safety test and EMC according to:	IEC 60601-1 IEC 60601-2-41 IEC 60601-1-2
GMDN-Code	12276
Service life of the light source:	
Service life LED	30'000h (L70/B50)

13 ELECTROMAGNETIC COMPATIBILITY (EMC)

Electromagnetic interference guidelines		
The medical device is intended for operation in an electromagnetic environment such as the one specified below. The user must ensure that it is operated in such an environment.		
Emissions	In accordance	Electromagnetic environment
High-frequency emissions (CISPR 11)	Group 1	The medical device uses HF energy exclusively for its internal function. This means that its HF emissions are very low, and it is unlikely that adjacent electronic devices will receive any interference.
High-frequency emissions (CISPR 11)	Class B	The medical device is intended for use in all facilities, including residential buildings and facilities that are directly connected (without a transformer) to the same low voltage network as residential buildings.
Emissions from harmonics (IEC 61000-3-2)	Class C	
Emissions from voltage fluctuations/flicker (IEC 61000-3-3)	Compliance	

Electromagnetic interference resistance guidelines			
The medical device is intended for operation in an electromagnetic environment such as the one specified below. The user must ensure that it is operated in such an environment.			
Interference resistance to	IEC 60601-1-2 testing level	Conformity level of the medical device	Electromagnetic environment
Electrostatic discharge (ESD) (IEC 61000-4-2)	Contact discharge: ± 6 kV Air discharge: ± 8 kV	± 6 kV ± 15 kV	Floors made of timber, concrete or ceramics tiles are preferred. Where synthetic floor covering is used, the relative humidity should be at least 30%.
Fast transients/electrical disturbance variables/bursts (IEC 61000-4-4)	Power supply cables: ± 2 kV Longer input and output cables: ± 1 kV	± 2 kV Not applicable	The quality of the mains power supply should match that of a typical business or hospital environment.
Surge voltages/surges (IEC 61000-4-5)	±1 kV phase-to-phase voltage ±2 kV phase-to-earth voltage	±2 kV ±1 kV	The quality of the mains power supply should match that of a typical business or hospital environment.
Magnetic field in the power supply frequency (50/60 Hz) (IEC 61000-4-8)	3 A/m	100 A/m	In proximity of this medical device, do not operate devices with unusually strong network-frequency magnetic fields (transformer stations etc.).
Voltage dips and short interruptions to the power voltage (IEC 61000-4-11)	Cut >95 %, 0.5 periods Cut 60 %, 5 periods Cut 30 %, 25 periods Cut >95 %, 5 seconds	Cut >95 %, 0.5 periods Cut 60 %, 5 periods Cut 30 %, 25 periods Cut >95 %, 5 seconds	The supply voltage quality should be that of a typical business or hospital environment. If the user requires continued function during any interruption of the energy supply system, we recommend that the medical device be powered by an uninterrupted power supply or a battery.
Radiated HF disturbance variable (IEC 61000-4-3)	3 V/m 80 MHz - 2.5 GHz	10 V/m	Recommended minimum distance of portable and mobile radio devices of PEIRP radiated power to the medical device, including its cables: $d = 0.35\sqrt{P}$
Conducted HF disturbance values (IEC 61000-4-6)	3 V _{rms-value} 150 kHz - 80 MHz:	10 V _{rms-value}	Recommended minimum distance of portable and mobile radio devices of PEIRP radiated power to the medical device, including its cables: 80 MHz – 800 MHz: $d = 0.35\sqrt{P}$ 800 MHz - 2.5 GHz: $d = 0.7\sqrt{P}$
d = recommended safe distance [m], P = Rated power of the sender [W]. Field strengths from fixed RF transmitters, as determined by an electromagnetic site survey should be less than the compliance level in each frequency range.			
Interference may occur in the vicinity of equipment marked with: 			

Recommended safe distances from portable and mobile HF communications equipment		
Rated Power of the sender [W]	150 kHz - 800 MHz	800 MHz - 2.5 GHz
0.01	0.035 m (0.11 ft)	0.07 m (0.23 ft)
0.1	0.11 m (0.36 ft)	0.22 m (0.72 ft)
1	0.35 m (1.15 ft)	0.7 m (2.30 ft)
10	1.11 m (3.64 ft)	2.21 m (7.25 ft)
50	2.47 m (8.10 ft)	4.95 m (16.24 ft)
100	3.5 m (11.48 ft)	7 m (22.97 ft)