

---

**VISIANO 10-1**  
EXAMINATION LIGHT





## VISIANO 10-1

VISIANO 10-1 was designed to be used universally for exams and procedures in the clinical sector. Seven premium LEDs and unique diamond optic technology offer low energy consumption and glare-free, shadow-free and heat-free high illumination. The sealed construction protects against contamination from outside sources. And the ergonomic handle and intuitive on/off switch allow for precise, reliable positioning and easy handling.

- Neutral daylight color rendering index of >93
- 34" reach with flexible arm
- 280° rotation of the light head
- 4400K color temperature
- Unique diamond optics and Premium LEDs for professional-grade light quality
- 7-inch illuminated field with 50,000 lux at .5 meter
- Various mounting options available for wall, rail or table mounting as well as for use with a rolling floor stand
- Electronics integrated for maximum safety and energy efficiency
- Sealed construction for contaminant- and maintenance-free operation
- Robust arm and friction joints ensure accurate positioning and durability



Timeless, slimline design with ergonomic handle



Diamond cluster optics for bright, consistent light





7 inches  
 ø 180 mm  
 approx. 50,000 lx/0.5 m

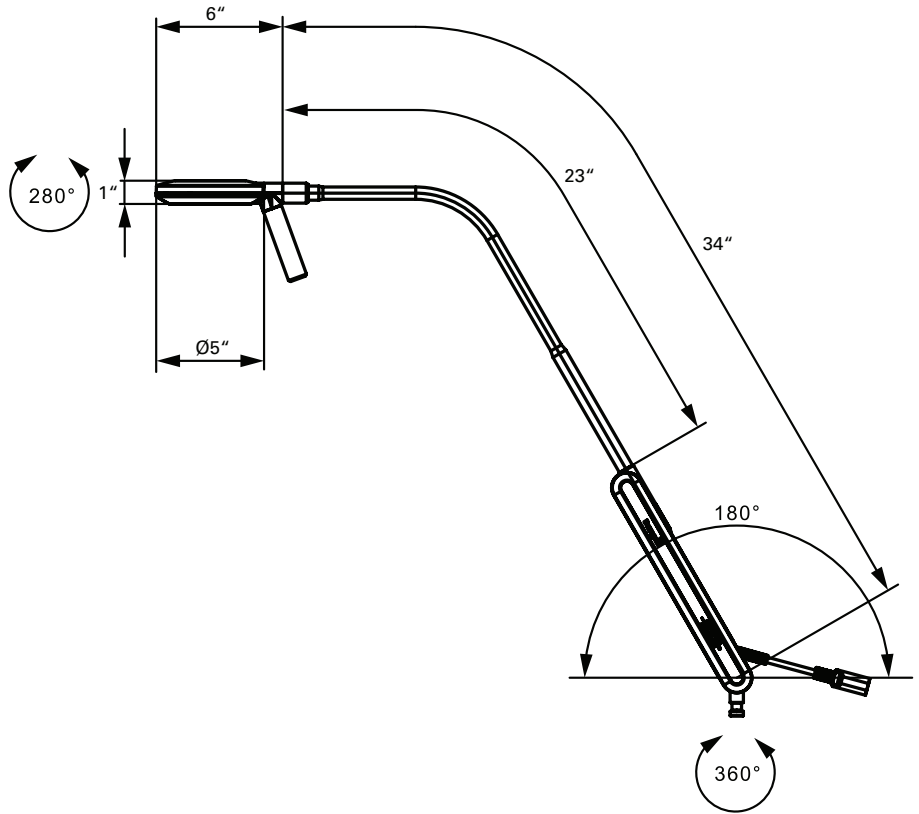
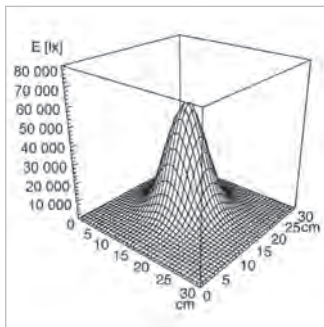

TECHNICAL		PRODUCT NUMBER	DESCRIPTION
Illumination intensity	approx. 50,000 lx / 0.5m	D15757100	VISIANO 10-1 P S10, gooseneck arm - clamp
Color rendering	Ra > 93	D15757110	VISIANO 10-1 P S10, gooseneck arm - floor stand
Color temperature	4400K	D15757120	VISIANO 10-1 P S10, gooseneck arm - wall mount
Illumination field 0.5m	Ø 7 inches	D15757150	VISIANO 10-1 P S10, gooseneck arm - rail mount
Operation	I/O switch on the arm		
Standards	IEC 60601-1		

## ACCESSORIES

ROLLER STAND		EXTENSION ARM	
Material	steel/plastic	Material	steel
Dimensions	39" pole, Ø 27.6" base	Weight (net)	1 lbs
Weight (net)	16.5 lbs	for stud Ø	16mm
for stud Ø	16mm-W with removal protection with cable suspension device	PRODUCT NO.	D13363000 - white
PRODUCT NO.	D15595000 - gray/white		

TABLE CLAMP		RAIL MOUNTING		WALL BRACKET	
Material	steel/polyresin	Material	anodized aluminum	Material	polyamide GF
Weight (net)	1 lb	Weight (net)	0.4 lbs	Weight (net)	0.3 lbs
for stud Ø	16mm	for stud Ø	16mm	for stud Ø	16mm
PRODUCT NO.	D14228000 - black	PRODUCT NO.	D13269000 - silver	PRODUCT NO.	D13231000 - white