

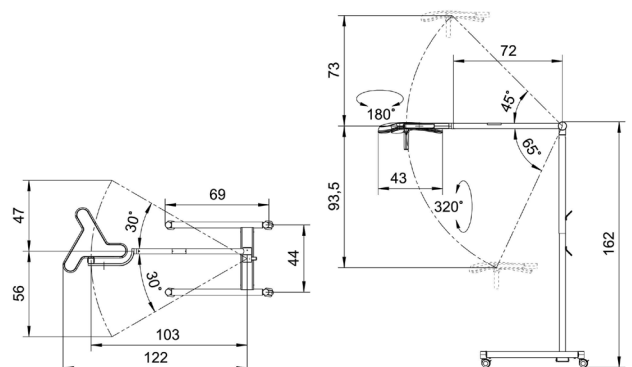

fitted with	LED - Energy efficiency category A+
Illuminancefield @ 100 cm	Ø 18 cm, (7 in)
illuminance @ 100 cm	100 000 lx
color rendering index (CRI)	>95
colour temperatur	3700/4300/4700 K
work equipment	electronic converter
mains lead	3 m, (9.84 ft)
luminaire body	polyamide (PA)
weight (net)	20 kg, (44 lb)
Power consumption	40 W
usage	keypad at luminaire head
balance of articulation joints	spring
class of protection	I
Accessory	sterilizable handle
norms	EN 60601-1, EN 60601-2-41
special features	3 color shades, 4 dimming levels, Diamond optics, High-quality arm system, sterilisable grip, maintenance free
Fastening	roller stand
System of protection	IP 20 (43)
order number	D15916000 - pure white

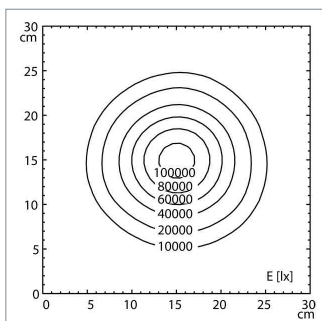

light distribution

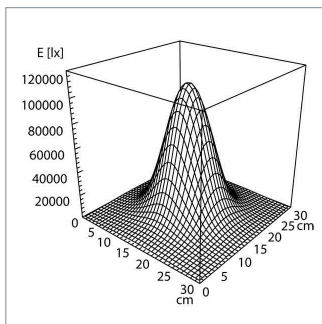

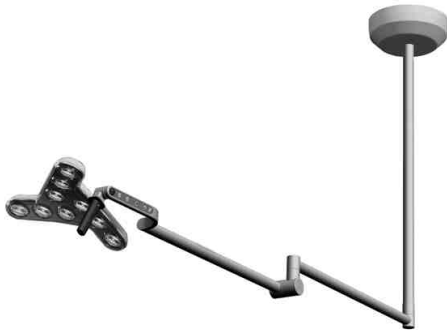

fitted with	LED - Energy efficiency category A+
Illuminancefield @ 100 cm	Ø 18 cm, (7 in)
illuminance @ 100 cm	100 000 lx
color rendering index (CRI)	>95
colour temperatur	3700/4300/4700 K
work equipment	electronic converter
luminaire body	polyamide (PA)
weight (net)	15.9 kg, (35 lb)
Power consumption	40 W
usage	keypad at luminaire head
balance of articulation joints	spring
class of protection	I
Accessory	sterilizable handle, adapter for suspended ceiling
norms	EN 60601-1, EN 60601-2-41
special features	3 color shades, 4 dimming levels, Diamond optics, High-quality arm system, sterilisable grip, maintenance free
Fastening	ceiling mount, when mounting ceiling tube could be cut to length 25-120 cm, intermediate ceiling adapter (on request)
System of protection	IP 20 (43)
order number	D16073000 - pure white



light distribution

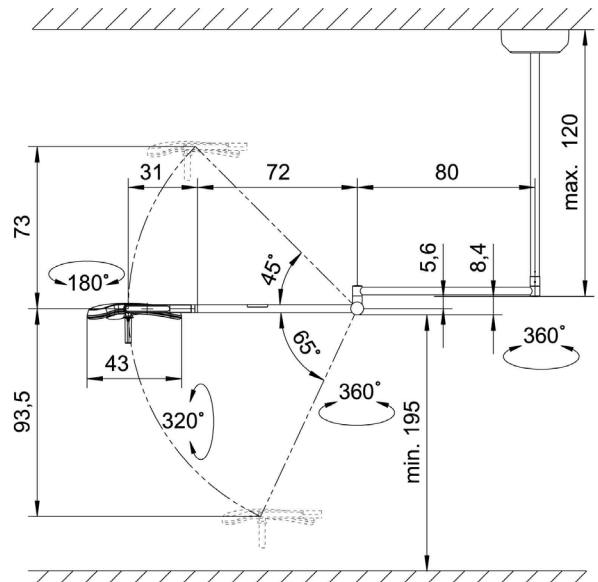
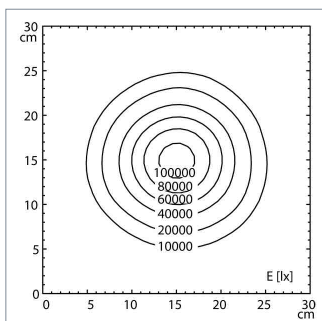
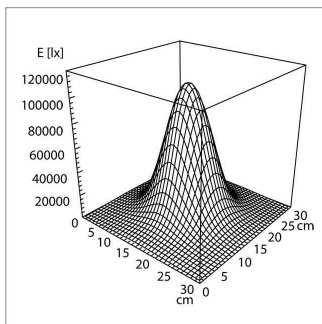



fitted with	LED - Energy efficiency category A+
Illuminancefield @ 100 cm	Ø 18 cm, (7 in)
illuminance @ 100 cm	100 000 lx
color rendering index (CRI)	> 95
colour temperatur	3700/4300/4700 K
work equipment	electronic converter
luminaire body	polyamide (PA)
weight (net)	15.3 kg, (33.7 lb)
Power consumption	40 W
usage	keypad at luminaire head
balance of articulation joints	spring
class of protection	I
Accessory	sterilizable handle
norms	EN 60601-1, EN 60601-2-41
special features	3 color shades, 4 dimming levels, Diamond optics, High-quality arm system, sterilisable grip, maintenance free
Fastening	wall
System of protection	IP 20 (43)
order number	D16078000 - pure white



light distribution

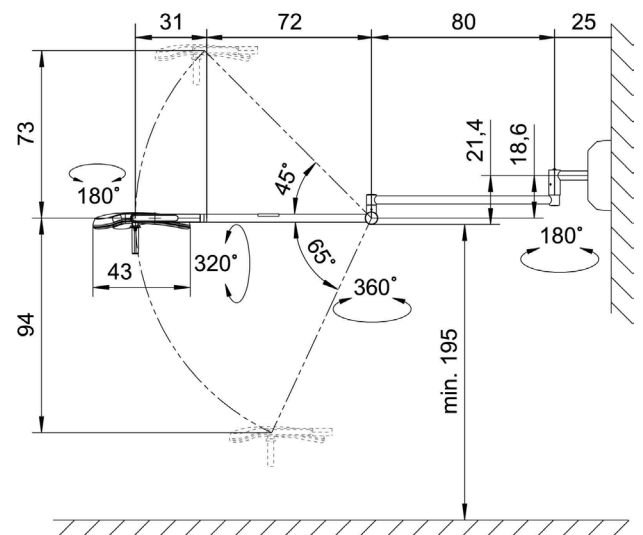
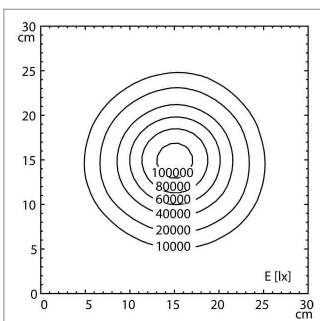
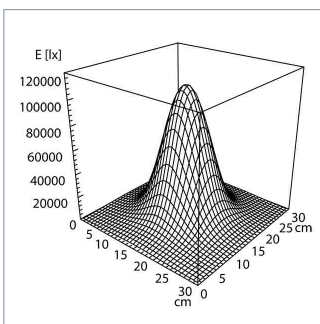

TRIANGO 100-3 F Battery

SKU: D16233000



- light source
- work equipment
- connected load
- power consumption
- color temperature
- color rendering index (CRI)
- luminous power
- illumination area
- luminaire body
- weight (net)
- usage
- balance of articulation joints
- protection rating
- class of protection
- standards met
- mains lead
- accessories
- mounting
- special features
- medical device class
- battery life cycle up to 70%
- battery type

- LED module
- electronic plug-in transformer
- 100-240 V, 50/60 Hz
- 40 W
- 3700K; 4300 K; 4700K
- >96
- 100 000 lux / 1.0 m
- 18 - 25 cm (7.1 - 9.8 in) @ 1.0m
- polyamide (PA)
- 70.5 lbs (32 kgs)
- keypad at luminaire head
- spring (weight compensation)
- IP 43 (luminaire head)
- IP 20 (UPSmed pack)
- I
- EN 60601-1, EN 60601-2-41
- 3 m cord (9.8 ft)
- sterilizable hand, handle cover
- roller stand
- diamond optics, sterilizable handle, 4 dimming levels
- I according to MDR
- 1,200 cycles
- NP17-12I industrial VRLA battery

light distribution

