

Examination Luminaire HALUX N30-1 P SVG

D15992100

Waldmann **W**

ENGINEER OF LIGHT.



Derungs
LIGHT FOR PEOPLE

fitted with
illuminance field @ 50cm
illuminance @ 50cm
color rendering index (CRI)
color temperature
work equipment
mains lead
luminaire body

weight (net)
power consumption
usage
balance of articulation joints
class of protection
accessory

norms
special features
fastening
mounting included
order number

LED module - energy efficiency category A+
Ø 18cm
30,000lx
> 93
4400K
electronic plug-in transformer
approx. 5.6ft (1.7m)
polycarbonate & acrylonitrile butadiene
styrene copolymer (PC & ABS)
approx. 3.5lbs (1.6kg)
8W
keypad at luminaire head
friction
II
roll support, rail fastening with removal
protection, table clamp with removal
protection, universal fastening with removal
protection, extension arm with removal
protection, wall bracket with removal
protection
EN 60601-1; EN 60601-2-41
continuously dimmable, maintenance free
fastening pin (Ø 16mm)
table clamp
D15992100 - pure white

light distribution

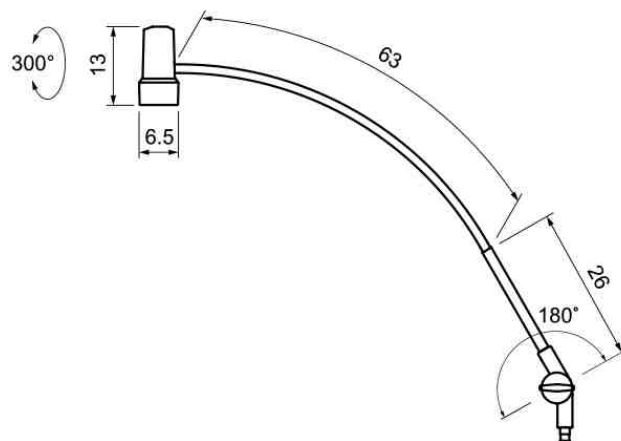
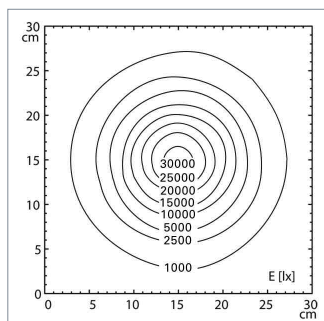
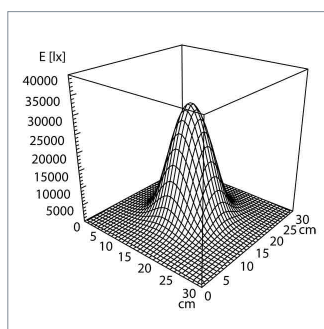

Examination Luminaire HALUX N30-1 P SVG

D15992110

Waldmann **W**

ENGINEER OF LIGHT.



Derungs
LIGHT FOR PEOPLE

fitted with
illuminance field @ 50cm
illuminance @ 50cm
color rendering index (CRI)
color temperature
work equipment
mains lead
luminaire body

weight (net)
power consumption
usage
balance of articulation joints
class of protection
accessory

norms
special features
fastening
mounting included
order number

LED module - energy efficiency category A+
Ø 18cm
30,000lx
> 93
4400K
electronic plug-in transformer
approx. 5.6ft (1.7m)
polycarbonate & acrylonitrile butadiene
styrene copolymer (PC & ABS)

approx. 3.5lbs (1.6kg)
8W
keypad at luminaire head
friction
II

roll support, rail fastening with removal
protection, table clamp with removal
protection, universal fastening with removal
protection, extension arm with removal
protection, wall bracket with removal
protection

EN 60601-1; EN 60601-2-41
continuously dimmable, maintenance free
fastening pin (Ø 16mm)
floorstand
D15992110 - pure white

light distribution

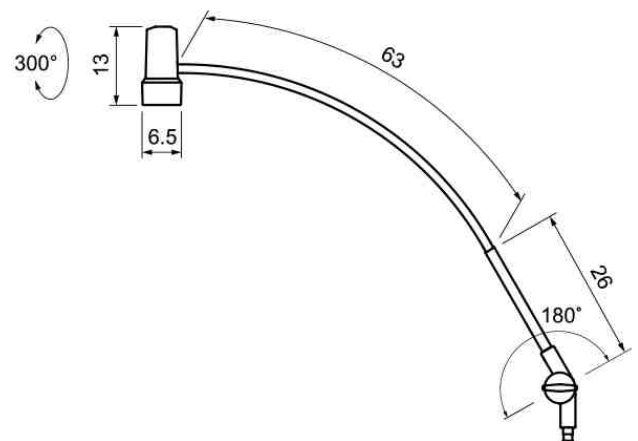
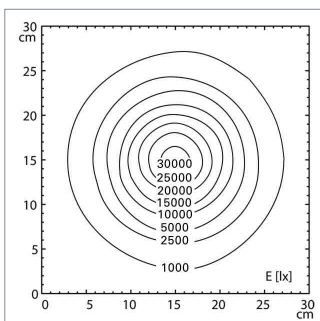
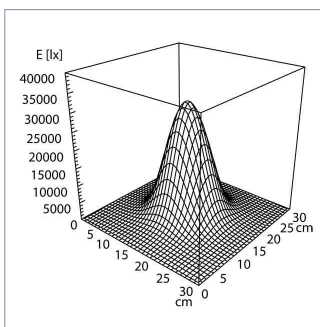

Examination Luminaire HALUX N30-1 P SVG

D15992120

Waldmann **W**

ENGINEER OF LIGHT.



Derungs **D**
LIGHT FOR PEOPLE

fitted with
illuminance field @ 50cm
illuminance @ 50cm
color rendering index (CRI)
color temperature
work equipment
mains lead
luminaire body

weight (net)
power consumption
usage
balance of articulation joints
class of protection
accessory

norms
special features
fastening
mounting included
order number

LED module - energy efficiency category A+
Ø 18cm
30,000lx
> 93
4400K
electronic plug-in transformer
approx. 5.6ft (1.7m)
polycarbonate & acrylonitrile butadiene
styrene copolymer (PC & ABS)
approx. 3.5lbs (1.6kg)
8W
keypad at luminaire head
friction
II
roll support, rail fastening with removal
protection, table clamp with removal
protection, universal fastening with removal
protection, extension arm with removal
protection, wall bracket with removal
protection
EN 60601-1; EN 60601-2-41
continuously dimmable, maintenance free
fastening pin (Ø 16mm)
wall mount
D15992120 - pure white

light distribution

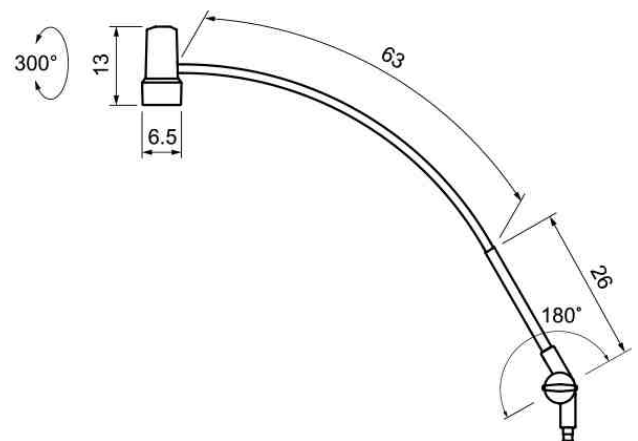
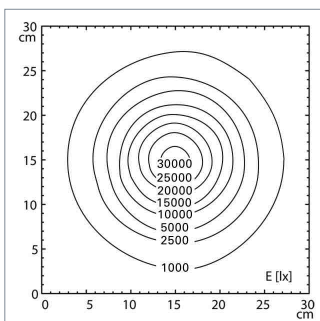
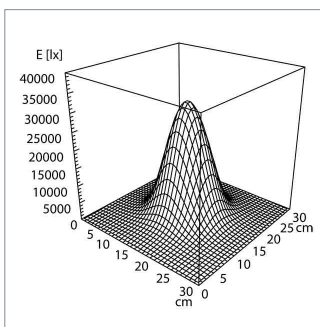

Examination Luminaire HALUX N30-1 P SVG

D15992130

Waldmann **W**

ENGINEER OF LIGHT.



Derungs
LIGHT FOR PEOPLE

fitted with
illuminance field @ 50cm
illuminance @ 50cm
color rendering index (CRI)
color temperature
work equipment
mains lead
luminaire body

weight (net)
power consumption
usage
balance of articulation joints
class of protection
accessory

norms
special features
fastening
mounting included
order number

LED module - energy efficiency category A+
Ø 18cm
30,000lx
> 93
4400K
electronic plug-in transformer
approx. 5.6ft (1.7m)
polycarbonate & acrylonitrile butadiene
styrene copolymer (PC & ABS)
approx. 3.5lbs (1.6kg)
8W
keypad at luminaire head
friction
II
roll support, rail fastening with removal
protection, table clamp with removal
protection, universal fastening with removal
protection, extension arm with removal
protection, wall bracket with removal
protection
EN 60601-1; EN 60601-2-41
continuously dimmable, maintenance free
fastening pin (Ø 16mm)
wall mount, extended arm
D15992130 - pure white

light distribution

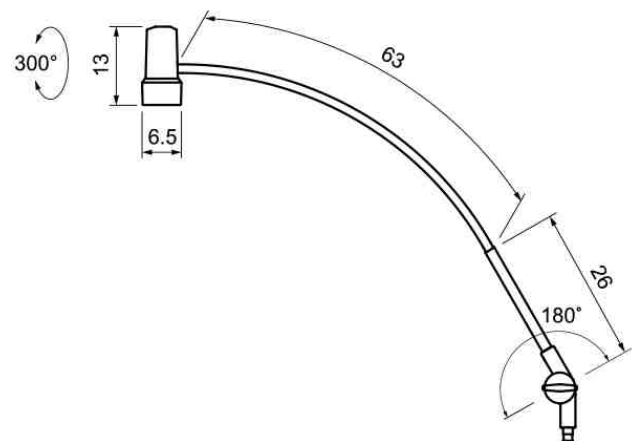
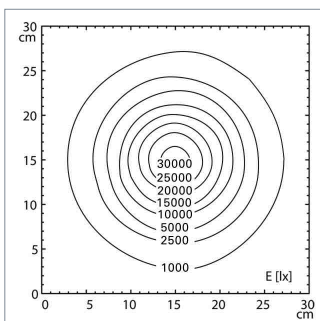
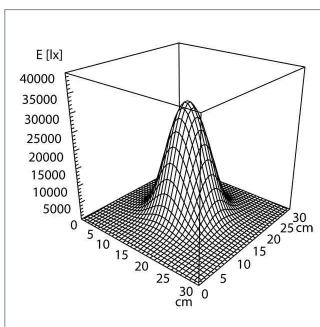

Examination Luminaire HALUX N30-1 P SVG

D15992150

Waldmann **W**

ENGINEER OF LIGHT.



Derungs
LIGHT FOR PEOPLE

fitted with
illuminance field @ 50cm
illuminance @ 50cm
color rendering index (CRI)
color temperature
work equipment
mains lead
luminaire body

weight (net)
power consumption
usage
balance of articulation joints
class of protection
accessory

norms
special features
fastening
mounting included
order number

LED module - energy efficiency category A+
Ø 18cm
30,000lx
> 93
4400K
electronic plug-in transformer
approx. 5.6ft (1.7m)
polycarbonate & acrylonitrile butadiene
styrene copolymer (PC & ABS)
approx. 3.5lbs (1.6kg)
8W
keypad at luminaire head
friction
II
roll support, rail fastening with removal
protection, table clamp with removal
protection, universal fastening with removal
protection, extension arm with removal
protection, wall bracket with removal
protection
EN 60601-1; EN 60601-2-41
continuously dimmable, maintenance free
fastening pin (Ø 16mm)
rail mount
D15992150 - pure white

light distribution

