

**Waldmann** **W**

ENGINEER OF LIGHT.

Instructions For Use **ENG**



**TANEO**  
STZL 12/24/36 (A)(R)

Column light

## Table of Contents

1.	<b>For your safety</b> .....	17
1.1	Designated use .....	17
1.2	Safety instructions.....	17
1.3	Warning levels.....	18
2.	<b>Model overview</b> .....	19
3.	<b>Mounting</b> .....	20
3.1	Mounting the fastening element.....	20
3.2	Mounting the light to the fastening element .....	20
4.	<b>Positioning</b> .....	21
4.1	Adjusting the column .....	21
4.2	Fastening the light head.....	21
5.	<b>Connection</b> .....	22
5.1	Connecting the grounding cable .....	22
5.2	Connecting the light to the mains voltage .....	22
5.3	Connecting the light to the 24 V supply voltage (SELV) .....	23
6.	<b>Functions of the light</b> .....	24
6.1	Operating functions.....	24
7.	<b>Operation</b> .....	24
7.1	Switch-on and switch-off.....	24
7.2	Dimming.....	24
8.	<b>What to do if?</b> .....	25
9.	<b>Replacing the lamp</b> .....	26
10.	<b>Cleaning</b> .....	26
11.	<b>Repair</b> .....	26
12.	<b>Disposal</b> .....	26
13.	<b>Technical Data</b> .....	27
13.1	Dimensions .....	27
13.2	Electrical values.....	27
13.3	Classifications .....	27
13.4	Symbols .....	27

## 1. For your safety

The light has been designed in accordance with state-of-the-art standards, manufactured with utmost care using high-quality materials, and tested.

Nevertheless, its use may constitute a risk to persons or cause material damage.



- ▶ Read all enclosed instructions and information.
- ▶ Please observe the warnings included in the documentation and attached to the unit.
- ▶ The device must only be used in technically perfect condition, and only by persons being aware of the risks and dangers involved in operating the device.
- ▶ Keep this document available near the device.

### 1.1 Designated use

The light is a workplace light and is designed for single workplace lighting. The light is used in addition to general lighting.

The light model STZL 24 **AR** has been especially designed for use in electrostatically protected areas (EPA).

### 1.2 Safety instructions

#### Explosion hazard

Operating the light in rooms subject to explosion hazards can trigger an explosion and result in serious injuries or death.

- ▶ **Do not** operate the light in rooms subject to explosion hazards.

#### Danger due to electric current

Improper use and faulty work on the light may result in injuries and material damage.

- ▶ Compare the mains voltage with the nominal voltage and the frequency specified on the rating plate and make sure that they are identical.
- ▶ Disconnect a damaged connecting cable immediately from the power supply and have it replaced by the manufacturer or by a qualified electrician.
- ▶ Have maintenance and repair work carried out by a skilled electrician only.
- ▶ Before performing work on the light, disconnect the light from the power supply.

#### Mount the light in a stable position.

A toppling light can result in personal injuries and material damage.

- ▶ Mount the light in a stable position.

#### Hazard caused by unsuitable spare parts

Unsuitable spare parts can result in injuries and material damage.

- ▶ Only spare parts released by the manufacturer may be used as spare parts.

#### Risk of corrosion

Operating the light in moist rooms can result in material damage.

- ▶ Operate in dry rooms only.

### 1.3 Warning levels

#### **DANGER!**

Warnings against hazards that result **directly in serious injuries or death** in case of non-observance.

#### **WARNING**

Warnings against hazards that may result in **serious injuries or death** in case of non-observance.

#### **CAUTION**

Warning against hazards that may result in **injuries** in case of non-observance.

#### **NOTICE**

Warning against hazards that may result in **material damage** in case of non-observance.

## 2. Model overview

For optimum installation and use of the light, you have to identify the light model unambiguously. To do so, you will require the model number of the light.

**NOTE:** The model number can be found on the column of the light.

- ▶ Check which model number the light has.
- ▶ Determine the light model by referring to the following table, see Tab. 1. For an explanation of the functions, see chapter 6 "Functions of the light", page 24.

**Example:** The model number **STZL 24 R** stands for the following light model:

<b>STZL</b>	<b>24</b>	<b>R</b>
TANEO column light	24 LED	Version R Functions: <ul style="list-style-type: none"> <li>▪ Switchable</li> <li>▪ Dimmable</li> </ul>

Type	Number of LEDs	Version	Functions
<b>STZL</b> TANEO column light	<b>12</b>	-	Switchable
	<b>24</b>	<b>R</b>	Switchable Dimmable
	<b>36</b>	<b>AR</b>	Switchable Dimmable Suitable for EPA

Tab. 1: Model overview.

### 3. Mounting

#### **CAUTION**

**Risk of injury caused by a falling or tilting light.**

Personal injury and material damage.

► Mount fastening elements correctly.

#### 3.1 Mounting the fastening element

##### **NOTICE**

**Material damage caused by missing ESD protection.**

Electrostatic discharge and damage to electronic components.

- In electrostatically protected areas (EPA), only lights suitable for EPA must be used.
- Use only fastening elements suitable for EPA.

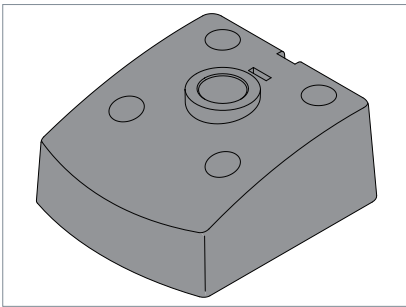

Fig. 1: Fastening element.

- Screw the fastening element to the mounting surface using four suitable screws.

#### 3.2 Mounting the light to the fastening element

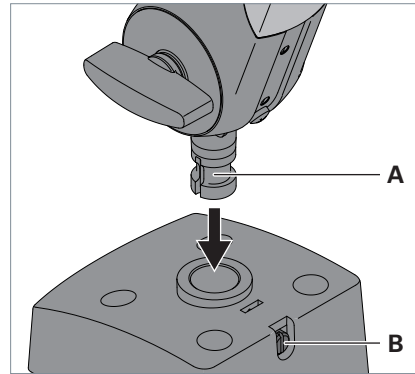

Fig. 2: Mounting the light to the fastening element.

- Insert the stud **A** on the light column into the opening of the fastening element, see Fig. 2.
- Tighten the screw **B** to fix the column, see Fig. 2.

## 4. Positioning

### 4.1 Adjusting the column

#### CAUTION

**Risk of injury caused by a falling or tilting light.**

Personal injury and material damage.

- ▶ Hold the light head when unscrewing the pivot screws.
- ▶ After positioning the column, tighten the pivot screws.

#### NOTICE

**Material damage caused by wrong handling.**

Damage to the light.

- ▶ Do **not** move the joints opposite to the intended direction of rotation.

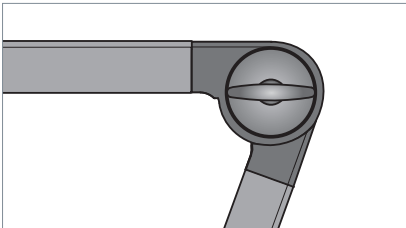

Fig. 3: Joint and pivot screw.

- ▶ Place the light in the desired position.
- ▶ Tighten each pivot screw until the light is fixed in the desired position.

### 4.2 Fastening the light head

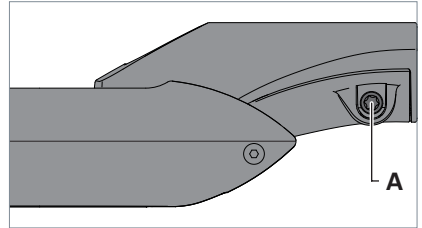

Fig. 4: Fastening the light head.

- ▶ Place the light head in the desired position.
- ▶ Tighten the friction screw **A** on the light head.

## 5. Connection

### NOTICE

#### Material damage caused by wrong handling.

Omission of the ESD protection and damage to electronic components.

- ▶ Lights suitable for EPA must remain plugged in in electrostatically protected areas (EPA).

### 5.1 Connecting the grounding cable

**NOTE:** This chapter applies only to lights suitable for EPA.

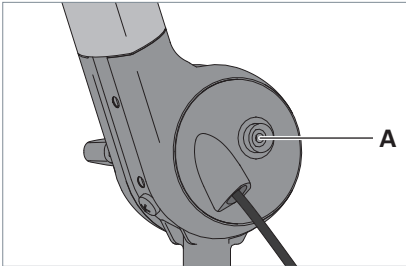

Fig. 5: Pushbutton for grounding cable.

- ▶ Connect one end of the provided grounding cable to the pushbutton **A** of the light, see Fig. 5.
- ▶ Connect the other end of the grounding cable to a grounding contact point.

### 5.2 Connecting the light to the mains voltage

### NOTICE

#### Material damage caused by wrong mains voltage.

Damage or destruction of the light.

- ▶ Compare the mains voltage with the nominal voltage and the frequency specified on the rating plate and make sure that they are identical.
- ▶ Connect the connecting cable of the light to the power supply unit.
- ▶ Plug the power supply unit into a socket.



### 5.3 Connecting the light to the 24 V supply voltage (SELV)

**NOTICE**

**Material damage caused by wrong mains voltage.**

Damage or destruction of the light.

- ▶ The connection must be made by a skilled electrician only.
- ▶ Compare the mains voltage with the nominal voltage and the frequency specified on the rating plate and make sure that they are identical.
- ▶ Operate the light with safety extra low voltage (SELV) only.

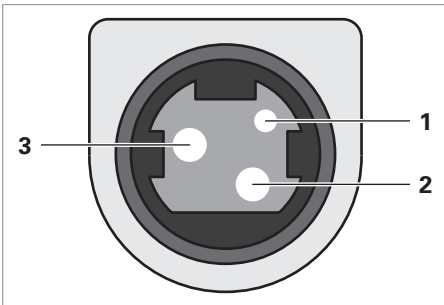

Fig. 6: Pin assignment.

No.	Designation
1	Not connected
2	DC +
3	DC -

**NOTE:** Please observe the pin assignment and the socket assignment.

- ▶ Plug the plug into the socket provided for this purpose.

## 6. Functions of the light

Depending on the light model, the light has different functions. If you want to find out which functions the light has, see chapter 2 "Model overview", page 19.

### 6.1 Operating functions

#### Switchable

This function can be used to switch the light on and off.

#### Dimmable

This function is used to change the brightness of the light.

#### Suitable for EPA

Lights with this function can be grounded and are suitable for use in electrostatically protected areas (EPA).

## 7. Operation

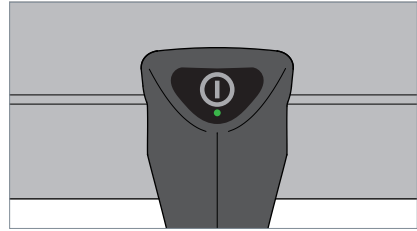

Fig. 7: Key.

### 7.1 Switch-on and switch-off

- ▶ Press the key, see Fig. 7

### 7.2 Dimming

- ▶ Press the key and keep it depressed, see Fig. 7.

After about one second, the light will change its brightness.

As soon as the maximum or minimum dimming value is reached, the LED in the key will flash.

- ▶ To change the dimming direction, press the key again and keep it depressed.

This will save the set brightness. The next time the light is switched on, the brightness saved last will be set.

## 8. What to do if?

Problem	Possible causes	Corrective action
Light is not lit.	Plug not plugged in.	▶ Plug the plug into a socket or into the socket provided for this purpose, see chapter 5 "Connection", page 22.
	Light is defective.	▶ Contact our service team.
Light does not respond to inputs.	Software function is defective.	▶ Unplug the plug for a few seconds.
		▶ If the light still doesn't respond, contact our service team.
The connecting cable is damaged.	Mechanical impact on the connecting cable.	▶ Disconnect a damaged connecting cable immediately from the power supply and have it replaced by the manufacturer or by a qualified electrician.

Tab. 2: What to do if?

## 9. Replacing the lamp

**NOTE:** The light is maintenance-free. A lamp replacement is not required.

## 10. Cleaning

### **WARNING**

#### **Danger of death due to electric shock.**

- ▶ Disconnect the light from the mains.
- ▶ Do **not** clean with a wet cloth.

### **NOTICE**

#### **Material damage caused by using wrong cleaning agents.**

Damage to the light.

- ▶ Make sure the cleaning agent is compatible with the surface.
- ▶ Clean the light with a cloth and a mild detergent.

## 11. Repair

### **NOTICE**

#### **Material damage caused by improper repair.**

Damage or destruction of the light.

- ▶ Have repairs performed only by the manufacturer or skilled personnel trained by the manufacturer.
- ▶ Only spare parts released by the manufacturer may be used as spare parts.

## 12. Disposal



The light is subject to European Directive 2002/96/EC.

- ▶ Dispose of the light separately from domestic waste using the agencies responsible for disposal and designated by the authorities.
- Proper disposal avoids adverse effects on man and the environment.

### 13. Technical Data

**NOTE:** The data given on the rating plate attached to the column of the light apply.

#### 13.1 Dimensions

Designation	Value
Light head	STZL 12 R: 218 x 136 x 33 mm STZL 24 (A)(R): 398 x 136 x 33 mm STZL 36 R: 577 x 136 x 33 mm
Column	400 + 384 + 252 mm
(variants)	450 + 244 + 252 mm 500 + 484 + 252 mm

Tab. 3: Dimensions.

#### 13.2 Electrical values

Designation	Value
Voltage range	
- Light	24 V DC
- Light + operating unit	100-240 V AC
Frequency range	
light + operating unit	50/60 Hz
Power consumption	Light: STZL 12 R: 13 W STZL 24 (A)(R): 26 W STZL 36 R: 37 W
	Light + operating unit: STZL 12 R: 15 W STZL 24 (A)(R): 31 W STZL 36 R: 47 W
Operating unit	Power supply unit





Tab. 4: Electrical values.

#### 13.3 Classifications

Designation	Value
Protection class	
- Light	III
- Light + operating unit	II
Type of protection	IP 20
Operating mode	Continuous operation
Technical safety check	EN 60598-1

Tab. 5: Classifications.

#### 13.4 Symbols

Symbol	Designation
	Protection class II Operation with protective insulation
	Protection class III Operation with safety extra low voltage (SELV)
	Suitable for the electrostatically protected area (EPA)
	CE conformity mark
	Disposal in accordance with European Directive 2002/96/EC

Tab. 6: Symbols.