

NOTES:

FRAME MATERIAL:
STEEL WITH 2.0mm LEAD EQUIVALENCE

GLASS WINDOW:
2.0mm LEAD EQUIVALENCE GLASS

FRAME COLOR:
TAN

NOT TO SCALE

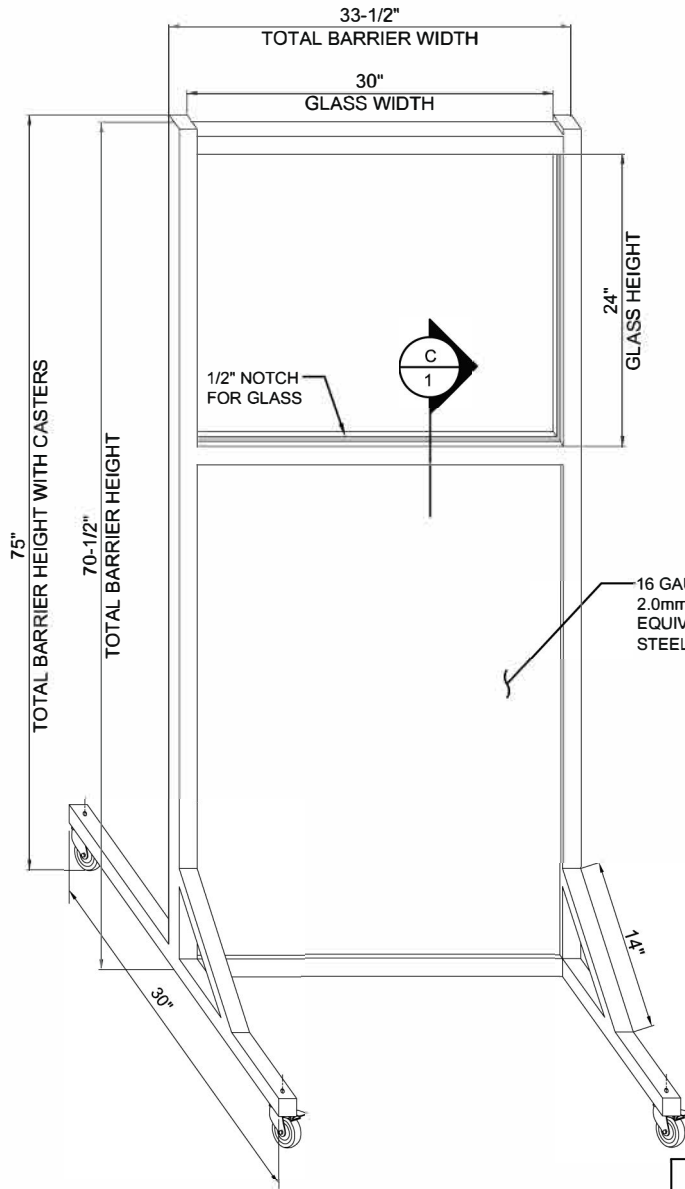

(A)
1 BARRIER ELEVATION

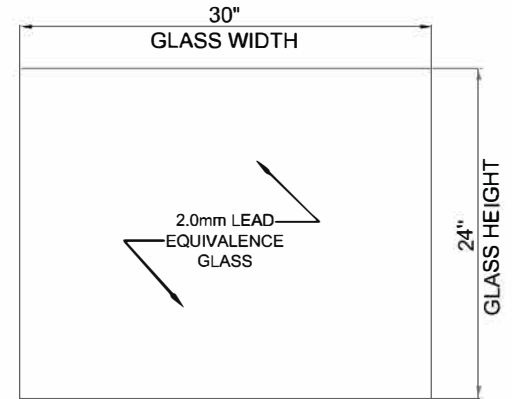

(B)
1 GLASS ELEVATION

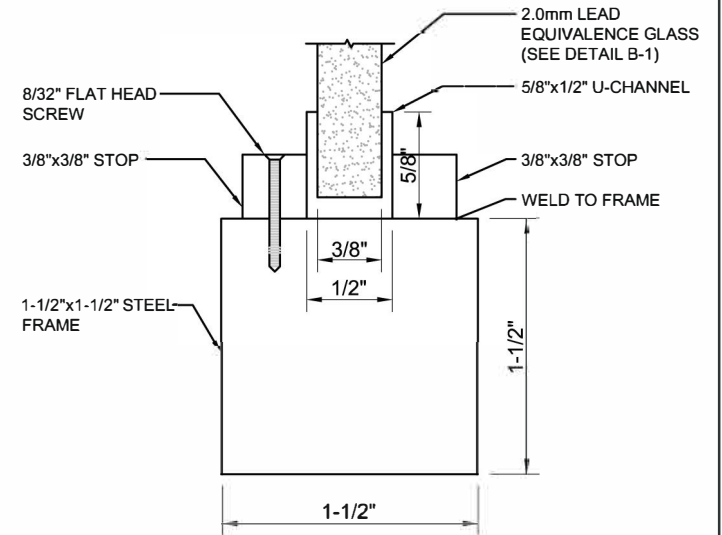

(C)
1 SECTION AT FRAME

DWG No.	LB-2430	Rev.
P/N:	LB-2430	
DESC.	Mobile Leaded Barrier w/24 inch Window	