

NOTES:

MATERIAL:
STEEL WITH 2.0mm LEAD EQUIVALENCE

PAD PRINT COLOR:
2.0mm LEAD EQUIVALENCE GLASS

FRAME COLOR:
TAN

NOT TO SCALE

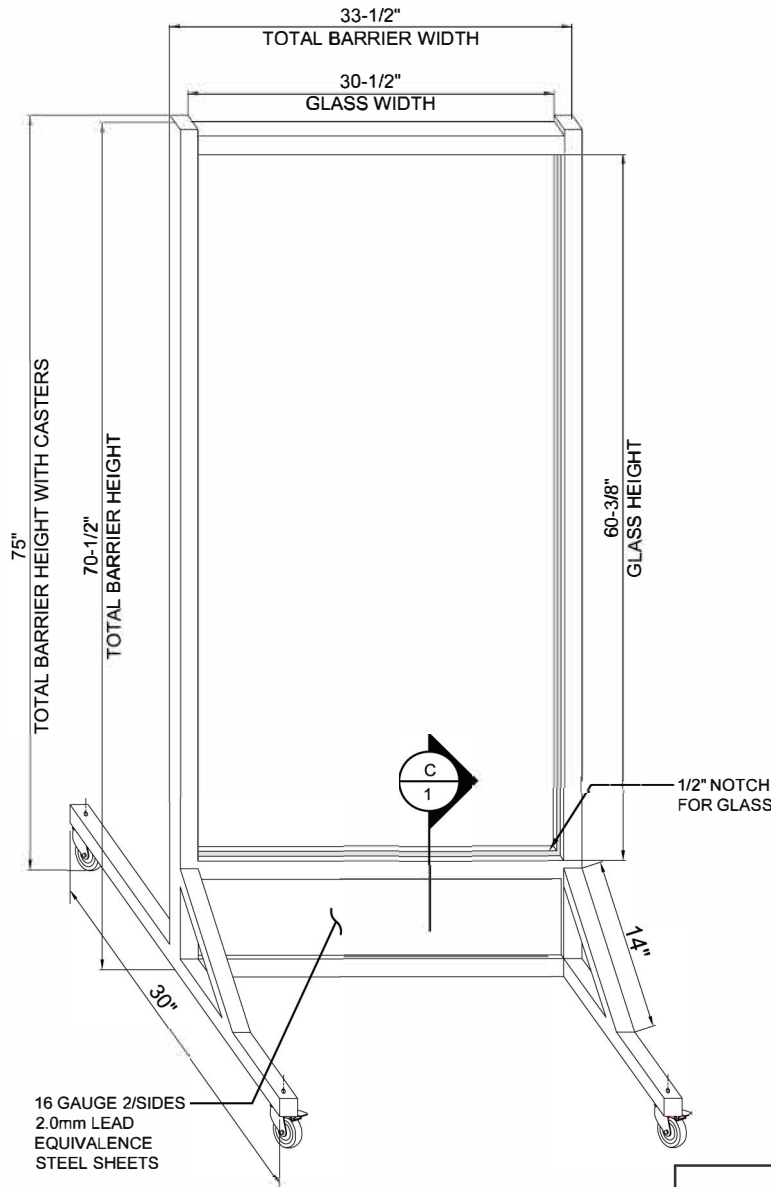

B GLASS ELEVATION

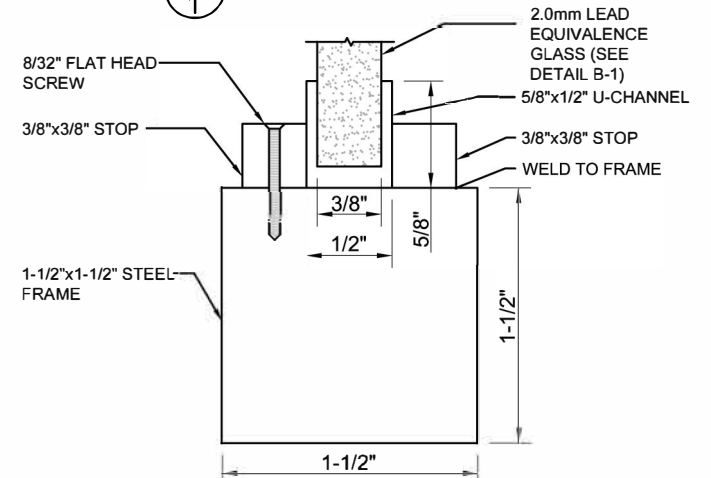
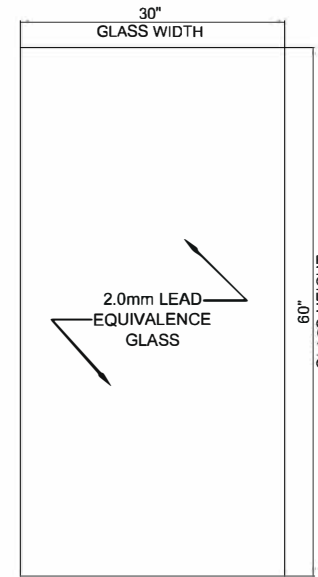

C SECTION AT FRAME

DWG No.	LB-3060	Rev.
P/N:	LB-3060	
DESC.	Mobile Leaded Barrier w/60 inch Window	