

# ECHO PRO ECHOCARDIOGRAPHY TABLE

---

OPERATION MANUAL

058-700  
058-705



---

# Echo Pro Echocardiography Table



**This manual covers operation procedures for the following products:**

058-700      Table, Echo Pro Echocardiography, 115 VAC  
058-705      Table, Echo Pro Echocardiography, 230 VAC

















---

# Table of Contents

Definition of Symbols .....	IV
Before Proceeding .....	V
Important Safety Information.....	VII
Warranty .....	IX
<b>CHAPTER 1: INTRODUCTION.....</b>	<b>1</b>
Intended Use.....	1
Indications for Use .....	1
General Cleaning and Maintenance Instructions.....	1
Table Parts and Adjustments.....	2
<b>CHAPTER 2: ASSEMBLY AND TABLE OPERATION .....</b>	<b>3</b>
Relocating the Table .....	3
Height Adjustment.....	3
Trendelenburg/Reverse Trendelenburg .....	3
Fowler Back Adjustment.....	4
Leveling The Table .....	4
Adjustable Sonographer Cutout Cushion .....	4
Cardiac Scanning Cutout .....	4
Installing and Using Optional Accessories.....	5
Foot Controller.....	5
Articulating Scanning Arm Board .....	6
Side Rails.....	7
Headrest Extension.....	8
Paper Dispenser .....	9
I.V. Pole.....	10
<b>APPENDIX A – SPECIFICATIONS.....</b>	<b>11</b>
<b>APPENDIX B - CONFORMANCE TO STANDARDS.....</b>	<b>12</b>
<b>APPENDIX C – SCHEMATICS.....</b>	<b>16</b>

# Definition of Symbols

The following symbols and their associated definitions are used and implied throughout this manual.

Symbol	Definition
	Carefully read these instructions prior to use
	Caution
	General Warning
	General Mandatory Action
	Dangerous Voltage
	“On” Power
	“Off” Power
	Earth (ground)
	Alternating Current
	Fuse
	USB Connector/Cable
	Waste in Electrical Equipment
	Date of Manufacture
	Type B Applied Part
	CE Mark
	CE Mark for products with EC Certificate
	Certified for Safety by ETL Intertek

---

## Before Proceeding



*NOTE: The warnings, cautions and instructions provided in this manual must be read, followed and kept available for consultation at all times. Observing the information, instructions and procedures presented throughout this manual is essential for using this product both properly and safely.*



### **SPECIFIC CAUTIONS**

- *Allow only qualified, trained personnel to operate or service this product.*
- *If the equipment is used in a manner other than specified in this operation manual, the protection provided by the equipment may be impaired and results could be compromised.*
- *Never leave patient unattended on table.*



### **EN GARDE SPÉCIFIQUES**

- *Permettez au personnel seulement autorisé, entraîné de faire marcher ou assurer l'entretien de ce produit.*
- *Si l'équipement est utilisé dans une manière autre qu'indiqué dans ce manuel d'opération, la protection fournie par l'équipement peut être diminuée et les résultats pourraient être compromis.*
- *Ne quittent Jamais le patient sans surveillance sur la table.*



**CAUTION:** *Unauthorized modifications to this product are not permitted and will void the manufacturer's warranty. Unauthorized modification of the product may result in a hazard to the user and/or patient. Do not modify this equipment without authorization from the manufacturer.*



**ATTENTION:** *Les modifications faites sans autorisation à ce produit ne sont pas permises et va faire le vide la garantie du fabricant. La modification faite sans autorisation du produit peut s'ensuivre dans un hasard à l'utilisateur et-ou le patient. Ne modifiez pas cet équipement sans autorisation du fabricant.*



**CAUTION:** *Before moving the table with a patient, make sure side rails are in the up position and body straps are in place to secure the patient.*



**ATTENTION:** *Avant le fait de déplacer la table avec un patient, assurez-vous que les rails de côté sont dans en haut la position et les courroies de corps dans l'endroit pour protéger le patient.*

---

## Training

This operation manual includes assembly and operating instructions. Operating/assembly questions can be directed to the service department during business hours.

## User Profile

### Patient

The product (without accessories) shall accommodate patients fitting the following profile:

Height: From infant to 74 inches (6ft - 2in)

Weight: Up to 500 lbs

Age: Infant to 65 years of age

### Sonographer

The product shall accommodate sonographers fitting the following profile:

5th percentile female, 20-65 years of age

95th percentile male, 20-65 years of age

## Product Certifications and Classifications

The Echo Pro Echocardiography Table has received the following certifications, and falls within the following classifications:

- ETL Listed Electrical Equipment, General Requirements for Safety conforms to EN 60601-1, 2nd ED, EN 60601-1:1998, EN 61000-6-1, EN 61000-6-2, EN 61000-6-3, EN 61000-6-4, EN 60601-1-2, EN 1970, UL 60601-1, 1st ED, 4-25-2003 rev 2006/04/26 and CAN/CSA C22.2 no.: 601.1M9.
- Type B Applied Part 
- Electromagnetic Compatibility: This equipment complies with the medical equipment IEC60601-1-2 EMC Standard.

## Authorized European Community Representative:



Emergo Europe  
Molenstraat 15  
2513 BH, The Hague  
The Netherlands

---

# Important Safety Information



**CAUTION:** Federal Law restricts this device to sale by or on the order of a physician, sonographer or other licensed professional.



**ATTENTION:** La Loi Fédérale restreint cet artifice à la vente par ou sur l'ordre d'un docteur, sonographe ou d'autre professionnel agréé.



Follow the unpacking and assembly instructions document.



Before using this equipment, read the entire operation manual carefully. Failure to read the manual may result in user error or injury. Be sure to save all provided documents for future reference.



Make certain to understand all warning and caution labels as explained in the Before Proceeding section of this manual.



This product should be used only as specified in the operation manual.



Biodex Ultrasound Tables are designed for use in a patient environment.



Les Tables d'Ultrasons de Biodex sont conçues à l'utilisation dans un environnement patient.



For product specifications, refer to the Table of Contents.



This medical electrical equipment requires special precautions regarding EMC and must be assembled and placed into service according to EMC information provided in this manual. For electromagnetic compliance definition, refer to the Table of Contents.



Reference Cleaning and Maintenance instructions in Table of Contents.



**CAUTION:** Operation for 058-700: 120 VAC, 60 Hz; 058-705: 230 VAC, 50 Hz.



**ATTENTION:** Opération pour 058-700: 120 VAC, 60 Hz; 058-705: 230 VAC, 50 Hz.



**WARNING:** Only use approved power supplies.



**AVERTISSEMENT:** N'utiliser que les alimentations homologuées



**CAUTION:** To avoid risk of electric shock, this equipment must only be connected to supply mains with protective earth.



**ATTENTION:** Pour éviter le risque de choc électrique, cet équipement doit uniquement être connecté à un approvisionnement conduites avec la terre protectrice.



**CAUTION:** The plug is considered the method of disconnecting the product from main power. Do not place the product in a position where the plug is not easily accessible.



**ATTENTION:** Le bouchon est considérée comme la méthode de déconnexion du produit d'alimentation. Ne placez pas le produit dans une position où le bouchon n'est pas facilement accessible.



**CAUTION:** This product is intended to remain in one location during operation. The product is provided with wheels for relocation and should be used when performing this operation. Once positioned, engage the central locking system lever to ensure stability.



**ATTENTION:** Le produit est voulu rester dans un emplacement pendant l'opération. Le produit est fourni avec les roues pour la relocalisation, et devrait être utilisé en exécutant cette opération. Une personne peut déplacer le produit.



---

# Biodex Medical Imaging Table Warranty

## 1. Product Warranty

- A. This equipment and its accessories (excluding cushions), are warranted by BIODEX MEDICAL SYSTEMS, INC. against defects in materials and workmanship for a period of two years from the date of shipment from BIODEX MEDICAL SYSTEMS, INC. During the warranty period, BIODEX MEDICAL SYSTEMS, INC. will in its sole discretion, repair (on-site), send replacement parts or replace the equipment found to have such defects, at no charge to the customer.

EXCEPT AS STATED ABOVE, THERE ARE NO WARRANTIES, EXPRESSED OR IMPLIED, INCLUDING WITHOUT LIMITATION WARRANTIES OR MERCHANTABILITY OR FITNESS FOR USE. BIODEX DOES NOT ASSUME LIABILITY FOR INCIDENTAL, CONSEQUENTIAL OR INDIRECT DAMAGES INCLUDING LOSS OF USE, SALES, PROFITS OR BUSINESS INTERRUPTION.

- B. This warranty does not apply if the product, as determined by BIODEX MEDICAL SYSTEMS, INC., is defective due to abuse, misuse, modification or service performed by other than a BIODEX MEDICAL SYSTEMS, INC. authorized repair representative. Misuse and abuse include, but are not limited to, subjecting limits and allowing the equipment to become contaminated by fluid materials.
- C. In order to obtain warranty repair service and to expedite repair process, please contact BIODEX MEDICAL SYSTEMS, INC. Support Services Dept. at 800-224-6339, and select product support as prompted.

## 2. Warranty is non-transferable.

## 3. Non-Warranty Service

- A. Repairs and/or replacements not covered by this warranty may be performed by BIODEX MEDICAL SYSTEMS, INC. authorized service representatives.
- B. The cost of transportation to and from the service location will be the responsibility of the customer.

---

## Service Procedure

If you think you have a service problem, take the following action:

1. Check to see that the problem occurs more than once.
2. Refer to the instruction manual and operations procedure.

If you still think you have a service problem, call BIODEX MEDICAL SYSTEMS, INC., Service Department at (800) 224-6339 and select product service as prompted.

Keep yourself and the phone next to the equipment.

1. Service will ask you for a brief description of the problem. We will ask specific questions about the malfunction that occurred. This diagnostic process may take a few minutes, so call us when you can set aside an uninterrupted block of time.
2. After taking the information, we will advise on the action we will take.
3. Sometimes service personnel must consult with engineering and it may take time to get back to you. Be sure to let the service representative know your schedule so that we can call at a convenient time.
4. The return call may be from a person other than whom you first reported the problem to.
5. After analyzing the problem, we will decide if the unit can be repaired on site, or replacement parts will be sent.
6. If the unit must be returned, Biodex will provide a return materials authorization number (R.M.A. #.) Pack the table in the carton that it was originally shipped in. It is the customer's responsibility for any damage that occurs during shipping.
7. Non-warranty/non-service contract charges for repair are as follows:
  - a. Materials  
+
  - b. Time  
+
  - c. Travel Zone

---

# 1. INTRODUCTION

## **Intended Use**

The Echo Pro Echocardiography Table is designed to provide a safe ergonomic environment for the sonographer and patient. The design features are intended to relieve musculoskeletal stress on the sonographer while scanning, and to provide the utmost patient comfort.

## **Indications For Use**

The Echo Pro Echocardiography Table is typically used in radiology departments, cardiovascular facilities, diagnostic imaging centers and private practice clinics to achieve quality images for a variety of procedures and patient applications.

## **General Cleaning and Maintenance**

1. As required, cleanse all exterior surfaces and tabletop pads with a mild detergent solution such as Parker Laboratories Protex Disinfectant or any one-step disinfectant that does not contain bleach.
2. Keep wheel assemblies free of foreign materials and dirt accumulation.
3. Periodically inspect all welds.
4. Periodically check bolts on table, tighten if necessary.
5. Periodically inspect all strap holders. Any holder that feels loose should be removed and reattached after adding a spot of Loctite® Threadlocker (Blue #242) to the bolt threads. This should ensure that the bolt will not loosen again in the future.

## Table Parts and Adjustments

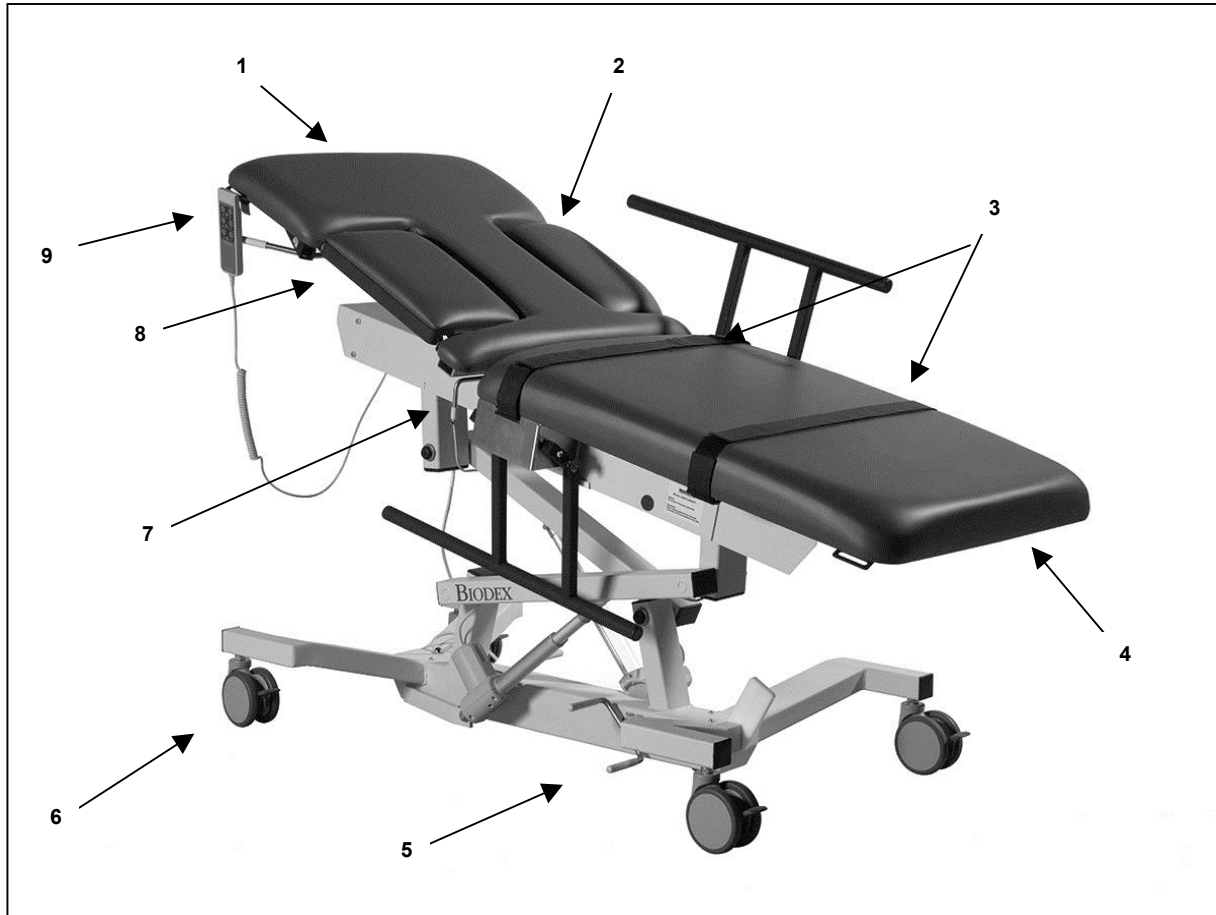

**Figure 1.** The Echo Pro Echocardiography Table parts and adjustment include:

**Standard Parts and Adjustments:**

1. Fowler Back
2. Cardiac Scanning Cutout Cushion
3. Restraining Straps
4. Extra-Wide Tabletop With 500-Lb Patient Capacity
5. Central Floor Locking System Lever
6. 5" Locking Swivel Casters
7. Return Cardiac Scanning Cushion to Level Lever
8. Adjustable Sonographer Cutout Cushion
9. Hand-Held Controller

**Optional:**

- 058-740 Foot Controller
- 058-633 Side Rails, Folding
- 058-736 Arm Board, Vascular Scanning
- 058-737 I.V. Pole
- 058-611 Dispenser, Paper, With Cutter Strap
- 058-738 Extension, Headrest

---

## 2. ASSEMBLY AND TABLE OPERATION

### Relocating The Table



**CAUTION:** Before moving the table with a patient, make sure side rails are in the up position and restraining straps are in place to secure the patient.



**ATTENTION:** Avant de déplacer la table avec un patient, assurez-vous que les rails latéraux sont dans les courroies hautes de position et de corps en place pour fixer le patient

This table can be easily moved across smooth surfaces.

To move the table, release the central locking system by pressing with your foot on the short end of the central locking lever. All four wheels release at the same time.

Once positioned, depress the end of the lever to engage the central locking system, ensuring stability.

**NOTE:** In addition to the central locking system, each wheel can be locked individually by stepping down on the individual wheel lock lever.

### Height Adjustment

Table height is conveniently adjusted with the hand-held or optional foot controller. D-ring holders are provided on the end of the straps at each side of the table frame to hold the hand-held controller when it is not in use. The hand-held controller can be moved to either side of the table. A power light on the controller indicates that power from the control box is on.

- To raise the table: press and hold down the table UP button.
- To lower the table: press and hold down the table DOWN button.

**NOTE:** The control box, located underneath the tabletop, is labeled with controller specific information.



**Figure 2.**  
Hand-held  
Controller  
activates table  
positions.

### Trendelenburg/Reverse Trendelenburg Positioning

The table can provide up to 15° Trendelenburg or -15° Reverse Trendelenburg positioning by raising or lowering either the head or foot end of the table with the hand-held or optional foot controller.

- For Trendelenburg positioning: press and hold down the foot-end button on the hand-held controller. This will simultaneously raise the foot end and lower the head end of the table. Release the button when the desired angle is achieved.

- 
- For Reverse Trendelenburg positioning: press and hold down the head-end button on the hand-held controller. This will simultaneously lower the foot end and raise the head end of the table. Release the button when desired angle is achieved.

### **Fowler Back Adjustment**

The motorized Fowler back is infinitely adjustable to 80° via the hand-held or optional foot controller.

### **Leveling The Table**

The table has a self-leveling feature which can be used when the table is in a Trendelenburg or Reverse Trendelenburg position.

- To level the table, press and hold both Fowler back buttons on the hand-held control.

### **Adjustable Sonographer Cutout Cushion**

To assure both patient and sonographer comfort, the adjustable sonographer cutout cushion can be fully lowered or raised to either of two positions.

- To fully lower the cushion, reach under the cushion and squeeze together the two sonographer cutout cushion release handles. This will release the cushion, which can now be lowered. To return the cushion back to the level position, squeeze the handles together and lift up on the cushion until it is higher than level and then lower the cushion back down until it locks in the level position.
- To raise the cushion, lift up on the cushion. There are two positions in which the raised cushion can be set. To set the cushion in the first raised position, lift the cushion two-thirds of the way to vertical and then allow it to slide back down slightly until you feel it lock into position. To raise the cushion to the fully raised position, lift the cushion all the way up to vertical and then allow it to move back slightly until it locks into place. To lower the cushion from either raised position, lift up on the sonographer cutout cushion release lever (located along the head-end of the cushion) and then lower the cushion.

### **Cardiac Scanning Cutout**

The cardiac drop-down cushion can be released by pressing the yellow release handle which can be found toward the lower end of the Fowler back section on each side of the table.

The cushion can be returned from either side of the table. From the right side you will find a handle located toward the head end of the table. By pressing this handle down, the cardiac cushion will return to level. From the left side of the table, simply push the cushion back up to level.

---

## Installing And Using Optional Accessories

**NOTE:** The tools needed to install all table accessories are provided with the table. These include a 7/16" wrench, a 9/16" wrench and a Phillips screwdriver.

### Foot Controller (058-740)

The optional foot controller uses three separate rocker style pedals to control tabletop height, Trendelenburg/Reverse Trendelenburg and Fowler positioning. (See Figure 3.)



**CAUTION:** When the table is used in a wet environment, it is recommended that the foot controller be covered with a plastic bag and sealed as watertight as possible.



**ATTENTION:** Quand la table est utilisée dans un environnement mouillé, il est recommandé que le contrôleur de pied soit couvert avec un sac de plastique et cacheté si inattaquable que possible.

To install the foot controller:

1. Locate the foot control port on the frame underneath the seat cushion.
2. Insert the foot controller plug into the port (labeled "foot control") so that the plug key faces up and slides fully into the port slot. The foot controller should now be ready for use.

Using the foot controller:

To use the foot controller, simply press and hold down the appropriate rocker switch with your foot to adjust the table as desired. Releasing the rocker switch at any time immediately stops the motion.



**Figure 3.** The optional foot controller can be used to adjust tabletop height, Trendelenburg/Reverse Trendelenburg, and Fowler positioning.

---

## Articulating Scanning Arm Board (058-736)

The optional Articulating Scanning Arm Board is installed by inserting the arm board tube into the receiving tube located on each side of the table below the Fowler back section. The arm board pivot is adjustable at any point along its 130° arc. To adjust, press the yellow button on the arm board and move to the desired location; release yellow button. (See Figures 4-7.)

To remove the arm board, press the release button beneath the receiving tube and pull to remove.

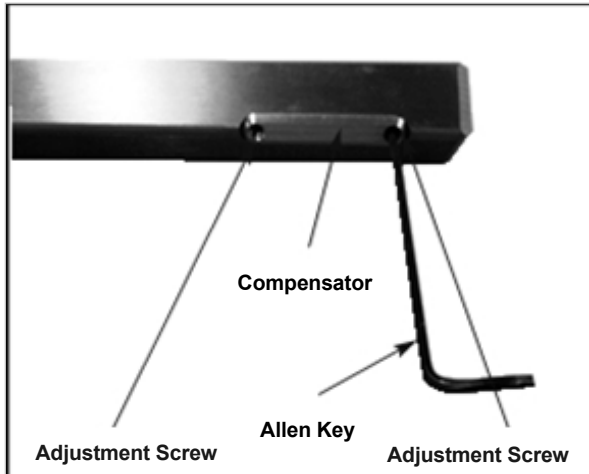

Figure 4.



Figure 5. The articulating scanning arm board.

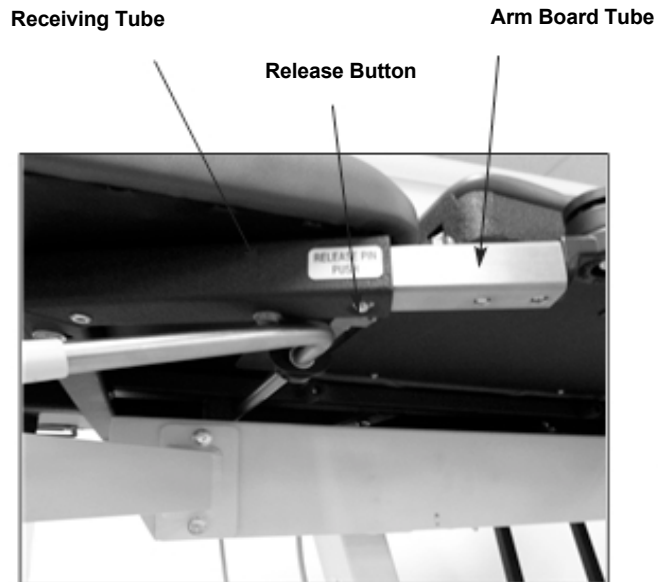

Figure 6.

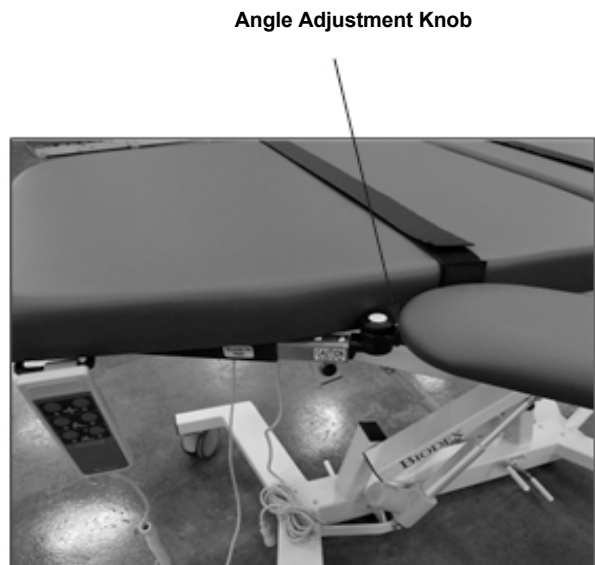

Figure 7.



## Side Rails (058-633)

The optional side rails can be installed on both sides of the table. Each rail pivots individually to either the raised or lowered position. Two rails are supplied; one for each side of the table.

### To install the side rails:

1. Using a 7/16" wrench, remove the four 1/4-20" hex head screws from under the abdominal cushion (toward the rear of the cushion) on the side of the table to which the side rail will be installed. Remove the strap bracket and save the screws to reinstall in step 3.
2. Position the side rail support bracket against the bottom of the cushion so the four pre-drilled screw holes in the bracket align with the screw holes under the seat cushion.
3. Using a 7/16" wrench install the four screws removed in step 1 through the side rail support bracket. Tighten securely.
4. Press the small piece of vinyl trim bumper onto the lower frame edge beneath the mid-point of the seat.
5. Install the straps into the side rails strap brackets.

### Using the side rails:

1. To raise either side rail, pull out the side rail pull pin and gently swing the rail upward so that it locks fully into position.
2. To lower either side rail, pull out the side rail pull pin and, while supporting the side rail, allow it to gently swing down and under the table until the rail locks in place.

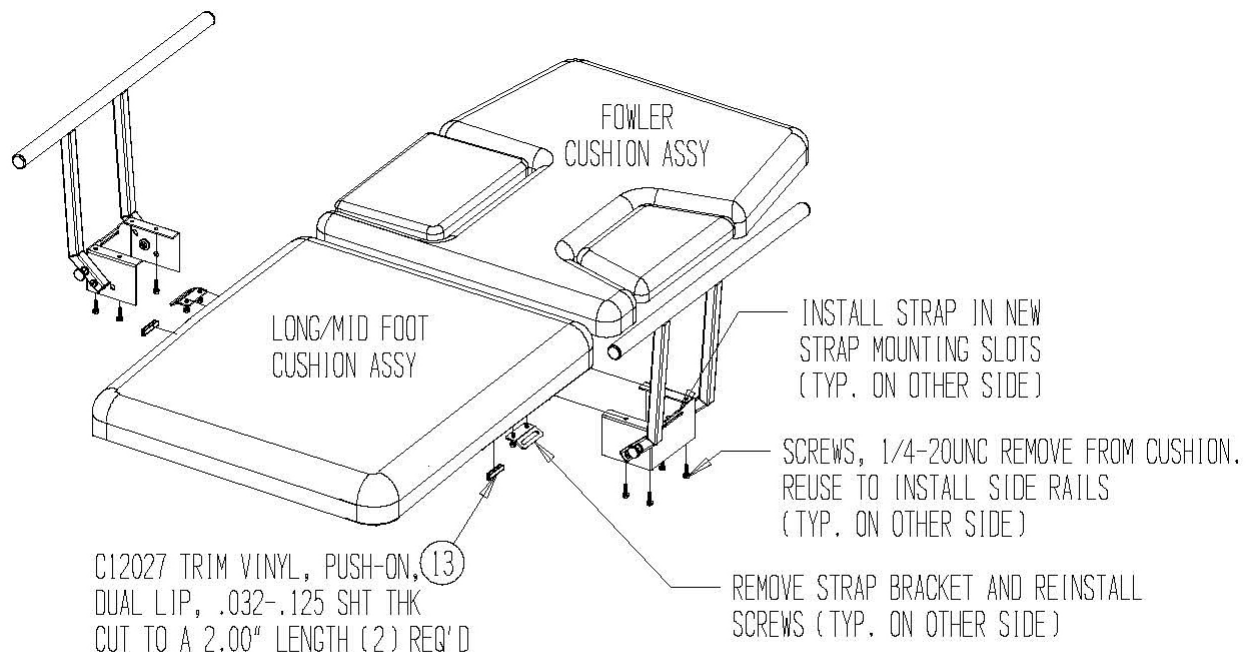

**Figure 8.** Installing the side rails.

---

## Headrest Extension (058-738)

The optional headrest is removable and adjustable. To install the headrest, simply slide it into the receiving tube at the head end of the table until it clicks into place.



*Figure 9. The optional headrest.*



*Figure 10. Headrest adjustments.*

## Paper Dispenser (058-611)

Manufactured to accommodate a roll of hygienic table paper (sold separately,) the optional paper dispenser is mounted to the head end of the table.

### Installing the paper dispenser:

1. Raise the Fowler back section of the table completely.
2. Using a 7/16" wrench, remove the two 1/4-20" hex head screws from under one side of the head end of the Fowler back cushion. (See Figure 11.)
3. Position the appropriate paper dispenser mounting bracket on the bottom of the Fowler back cushion as shown below. Ensure the pre-drilled screw holes align with the screw holes from step 2.
4. Using a 7/16" wrench, install the two 1/4-20" hex head screws removed in step 1 through the dispenser mounting bracket and tighten to secure the paper dispenser bracket in place.
5. Repeat steps 1 - 4 for the opposite side.
6. Place a role of paper on the paper dispenser rod and install the rod between the brackets. Press in on either spring-loaded end of the paper dispenser bar in order to slide it into the brackets.
7. Pull the paper over the cushions.
8. Pull unused paper through the cutter strap which mounts at the foot end of the table.
9. After use, cut the paper and dispose of used portions.



Mounting Bracket

Mounting Bracket

*Figure 11. Using a 7/16" wrench, install the two 1/4-20" hex head screws removed in step 1 through the dispenser mounting bracket and tighten to secure the paper dispenser bracket in place. Repeat steps 1 - 4 for the opposite side.*



*Figure 12. Place a roll of paper on the paper dispenser rod and install the rod between the brackets. Press in on either spring-loaded end of the paper dispenser bar in order to slide it into the brackets.*

## I.V. Pole (058-737)

The optional I.V. pole must be installed on the patient's right side of the table.

### Installing the I.V. pole:

1. Using a 7/16" wrench, remove the two 1/4-20" hex head screws from the end of the tabletop frame on the side of the table to which the I.V. pole will be installed.
2. Position the I.V. pole support bracket against the side frame so the two pre-drilled screw holes in the bracket align with the screw holes on the tabletop frame. The I.V. pole should face up and toward the head end of the table.
3. Using a 7/16" wrench, install the two screws removed in step 1 through the I.V. pole mounting bracket. Tighten the screws to secure.
4. Insert the I.V. pole into the I.V. pole mounting bracket. Ensure that the I.V. pole passes through both the top and bottom holes in the mounting bracket to ensure I.V. pole stability.

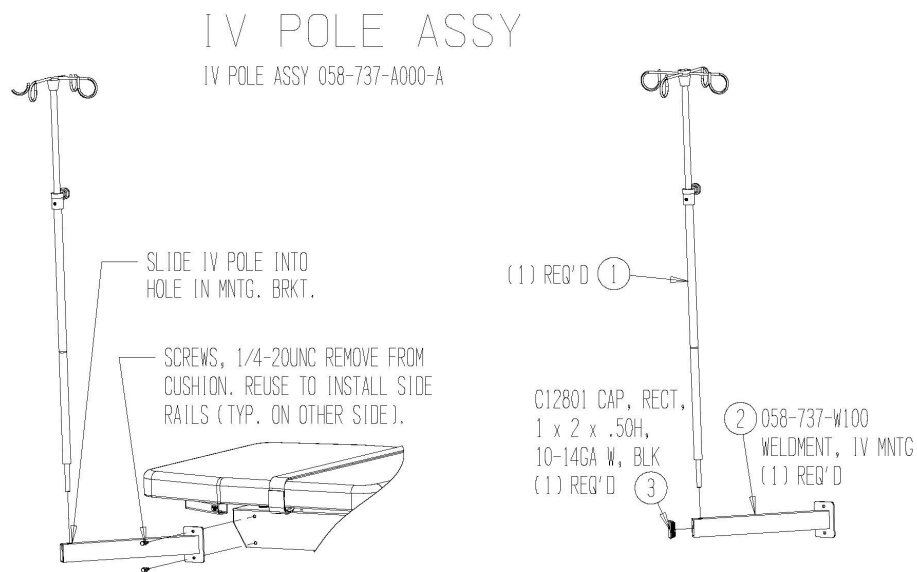

*Figure 13. Installing the I.V. pole.*

---

# APPENDIX A - SPECIFICATIONS

**Dimensions:** 73" l x 30" w (185.4 x 76.2 cm); 35" w (88.9 cm) with optional side rails

**Height Adjustable:** 23" to 39" (58.4 to 99 cm)

**Tabletop:** Two primary sections: torso section features sonographer and patient cutouts with Fowler positioning; lower body section remains fixed

**Cardiac Scanning Cutout:** 15.75" l x 9.5" w (40 x 24.1 cm) drop-down cushion releases from either side of the table

**Sonographer Cutout:** 8" w x 14.75" l (20.3 x 37.4 cm) adjustable sonographer cushion drops down or folds up for maximum access to the patient.

**Mattress:** Torso section 2" (5 cm) thick, lower body section 3" (7.6 cm) thick; foam rubber pad covered with seamless, durable Naugahyde®

**Upholstery Color:** Graphite

**Motions:**

**Height Adjustable:** 23" to 39" (58.4 to 99 cm)

**Trendelenburg:** 0° to 15°

**Reverse Trendelenburg:** 0° to -15°

**Fowler Back:** 0° to 80° infinitely adjustable

**Controls:**

**Hand Control:** Activates height, Trendelenburg motions, Fowler positioning and auto level motions

**Foot Control (optional):** Activates height, Trendelenburg motions, and Fowler positioning

**Wheels:** 5" (12.7 cm) individual locking swivel casters; central floor locking system

**Patient Restraints:** Two body straps

**Finish:** Powder coat

**Patient Capacity:** 500 lb (227 kg); Weight tested to four times the patient load rating

**Weight:** 335 lb (152 kg)

**Power:** 115 VAC or 230 VAC

**Warranty:** Two years parts and labor

**Certifications:** ETL and CETL listed to UL60601-1 and CAN/CSA C22.2 No. 601.1-M90 and EN60601-1 standards



**Authorized European Community Representative:**

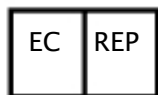

Emergo Europe  
Molenstraat 15  
2513 BH, The Hague  
The Netherlands

---

# APPENDIX B – CONFORMANCE TO STANDARDS

This equipment conforms to the following safety standards:

<i>Standard</i>	<i>Edition and/or date</i>
IEC60601-1-2	First edition, 2007

**Table 1.1 Safety standards**

## **Accompanying EMC Documents**

This medical electrical equipment needs special precautions regarding EMC and needs to be installed and put into service according to the EMC information provided in this manual.

- Portable and mobile RF communications equipment can affect medical electrical equipment.
- Use of accessories, transducers and cables other than those specified with the exception of accessories, transducers and cables sold by the manufacturer of this equipment, as replacement parts for internal and external components, may result in increased emissions or decreased immunity of the equipment.
- The Ultrasound Table should not be used adjacent to or stacked with other equipment. If the Ultrasound Table is used while positioned adjacent to other equipment, it should be observed to verify normal operation in the configuration in which it will be used.

## **List of Cable Accessories**

The list in Table 1.2 includes all accessory cables supplied with the Ultrasound Table for which the manufacturer of this equipment claims compliance to EN 60601-1-2 when used with the Ultrasound Table.

<i>Cable description</i>	<i>Part no.</i>	<i>Cable length</i>
N/A		

**Table 1.2 Ultrasound Table cables**

## Declaration of Conformity

### Emissions

<i>Manufacturer's declaration on electromagnetic emissions</i>		
The Ultrasound Table is intended for use in the electromagnetic environment specified below. The customer or the user of the Ultrasound Table should assure that it is used in such an environment		
<i>Emission test</i>	<i>Compliance</i>	<i>Electromagnetic environment</i>
RF emissions CISPR 11	Group 1	The Ultrasound Table generates RF energy only for its internal functions. Therefore, its RF emission is very low and is not likely to cause any interference in nearby electronic equipment
RF emissions CISPR 11	Class BB	The Ultrasound Table is suitable for use in all establishments including domestic establishments and those directly connected to the public low-voltage power supply network supplying buildings used for domestic purposes.

### Immunity

<i>Manufacturer's declaration on electromagnetic immunity</i>			
The Ultrasound Table is intended for use in the electromagnetic environment specified below. The customer or the user of the Ultrasound Table should assure that it is used in such an environment.			
<i>Immunity test</i>	<i>IEC 60601-1-2 Test level</i>	<i>IEC 60601-1-2 Compliance level</i>	<i>Electromagnetic environment – guidance</i>
Electrostatic discharge (ESD) IEC 61000-4-2	± 4 kV contact ± 8 kV air	Contact±4 kV Air ± 8 kV	Floor should be wood, concrete or ceramic tiles. If floor is covered with synthetic material, the relative humidity should be at least 30%

<i>Immunity test</i>	<i>IEC 60601-1-2 Test level</i>	<i>IEC 60601-1-2 Compliance level</i>	<i>Electromagnetic environment – guidance</i>
Conducted RF IEC 61000-4-6 Radiated RF IEC 61000-4-3	3 Vrms, 150 KHz to 80 MHz 3 V/m, 80 MHz to 2.5 GHz	3 Vrms, 150 KHz to 80 MHz 3 V/m, 80 MHz to 2.5 GHz	<p>Portable and mobile RF communications equipment should be used no closer to any part of the Ultrasound Table, including cables, than the recommended separation distance calculated from the equation applicable to the frequency of the transmitter.</p> <p>Recommended separation distance:  <math>d = 1.2 \sqrt{P}</math> P 150 KHz to 80 MHz  <math>d = 1.2 \sqrt{P}</math> P 80 MHz to 800 MHz  <math>d = 2.3 \sqrt{P}</math> P 800 MHz to 2.5 GHz            where P is the maximum output power rating of the transmitter in watt (W) according to the transmitter manufacturer, and d is the recommended separation distance in meters (m).</p> <p>Field strengths from fixed RF transmitters, as determined by an electromagnetic site survey,<sup>a</sup> should be less than the compliance level in each frequency range.<sup>b</sup></p> <p>Interference may occur in the vicinity of equipment marked with the following symbol:</p> 

**Note 1.** UT is the a.c. mains voltage prior to application of the test level.

**Note 2.** At 80 MHz and 800 MHz, the higher frequency range applies.

**Note 3.** These guidelines may not apply in all situations. Electromagnetic propagation is affected by absorption and reflections from structures, objects and people.

<sup>a</sup> Field strength from mixed transmitters, such as base stations for radio telephones and land mobile radios, amateur radio, AM or FM broadcast and TV broadcast cannot be predicted theoretically with accuracy. To assess the electromagnetic environment due to fixed RF transmitters, an electromagnetic site survey should be considered. If the measured field strength in the location in which the Ultrasound Table is used exceeds the applicable RF compliance levels above, the Ultrasound Table should be observed to verify normal operation. If abnormal performance is observed, additional measures may be necessary, such as reorienting or relocating the Ultrasound Table.

<sup>b</sup> Over the frequency range 150 KHz to 80 MHz, field strengths should be less than 3 V/m.



## Recommended Separation Distances

<i>Recommended separation distances between portable and mobile RF communications equipment and the Ultrasound Table.</i>			
The Ultrasound Table is intended for use in the electromagnetic environment in which radiated RF disturbance are controlled. The customer or the user of the Ultrasound Table can help prevent electromagnetic interference by maintaining a minimum distance between portable and mobile RF communication equipment (transmitters) and the Ultrasound Table as recommended below, according to the maximum output power of the communication equipment.			
<i>Rated maximum output power of transmitter [W]</i>	<i>Separation distance according to frequency of transmitter [m]</i>		
	150 kHz to 80 MHz $d = 1.2! P$	80 MHz to 800 MHz $d = 1.2! P$	800 MHz to 2.5 GHz $d = 2.3! P$
0.01	0.12	0.12	0.23
0.1	0.38	0.38	0.73
1	1.2	1.2	2.3
10	3.8	3.8	7.3
100	12	12	23
For transmitters rated at a maximum output power not listed above, the recommended separation distance in meters (m) can be estimated using the equation applicable to the frequency of the transmitter, where P is the maximum output power rating of the transmitter in watts (W) according to the transmitter manufacturer.			
<b>Note 1.</b> At 80 MHz and 800 MHz, the separation distance for the higher frequency range applies.			
<b>Note 2.</b> These guidelines may not apply in all situations. Electromagnetic propagation is affected by absorption and reflection from structures, objects and people.			

## Operating Temperature

Do not expose the equipment to a temperature change of more than 5° F (3° C) per hour.

Limits of low and high operating temperature ranges are 59° to 86° F (15° C to 30° C).

# APPENDIX C – PARTS AND ASSEMBLY ILLUSTRATIONS

## TABLE, ECHO ECONOMY TBLECHDECON058-700-A005-B1

NOTES:  
1-THIS DRAWING IS FOR THE FOLLOWING ASSY:  
058-701-A005, TABLE ECHO PRO (120V)  
058-706-A005, TABLE ECHO PRO (220V)

### ELECTRICAL RATINGS

MODEL	VOLTAGE	AMPS	CYCLES	WATTS
058-700 DUFF NORTON	115 VAC	2.4 A	50/60 Hz	175 W
058-705 DUFF NORTON	230 VAC	1.2 A	50/60 Hz	175 W

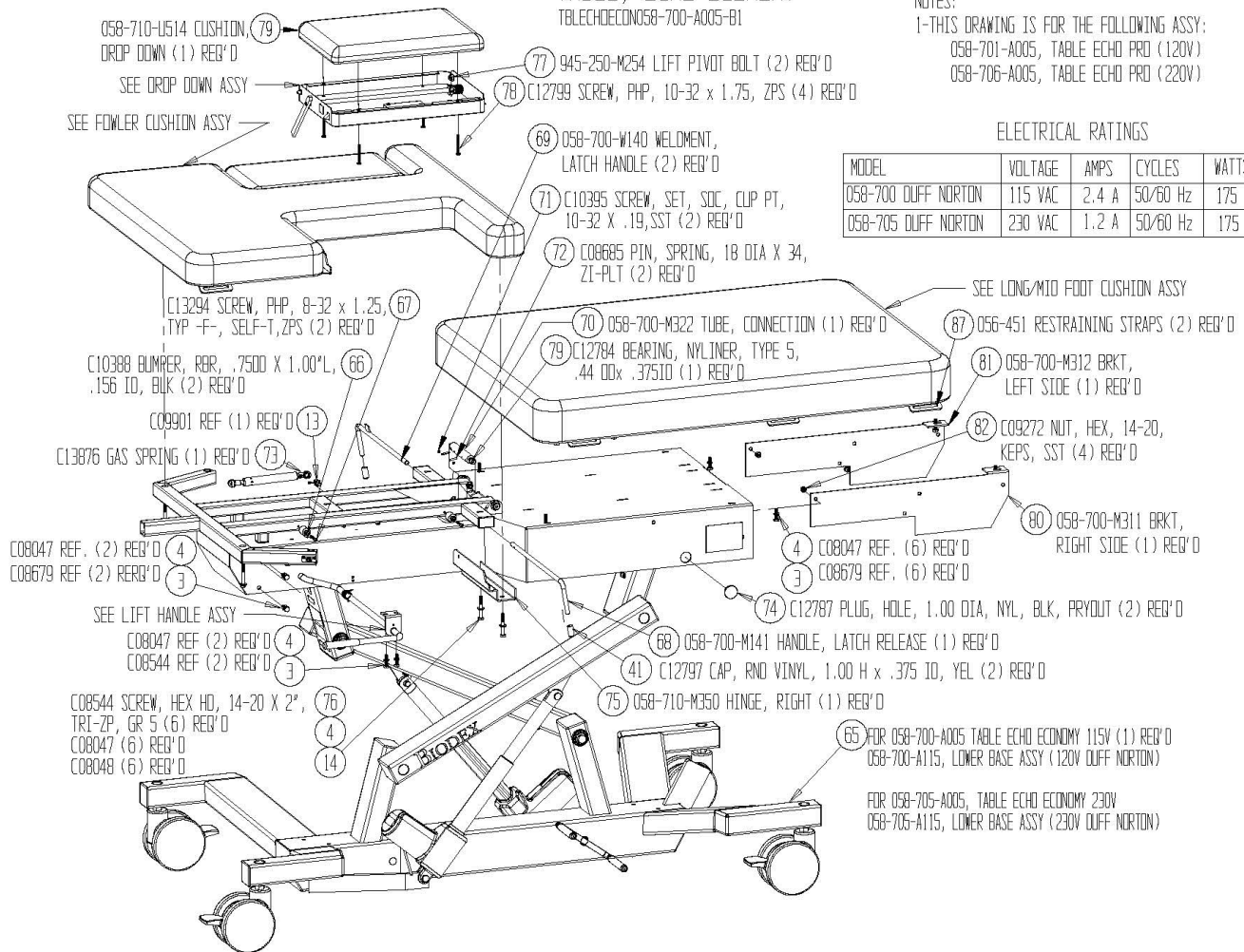



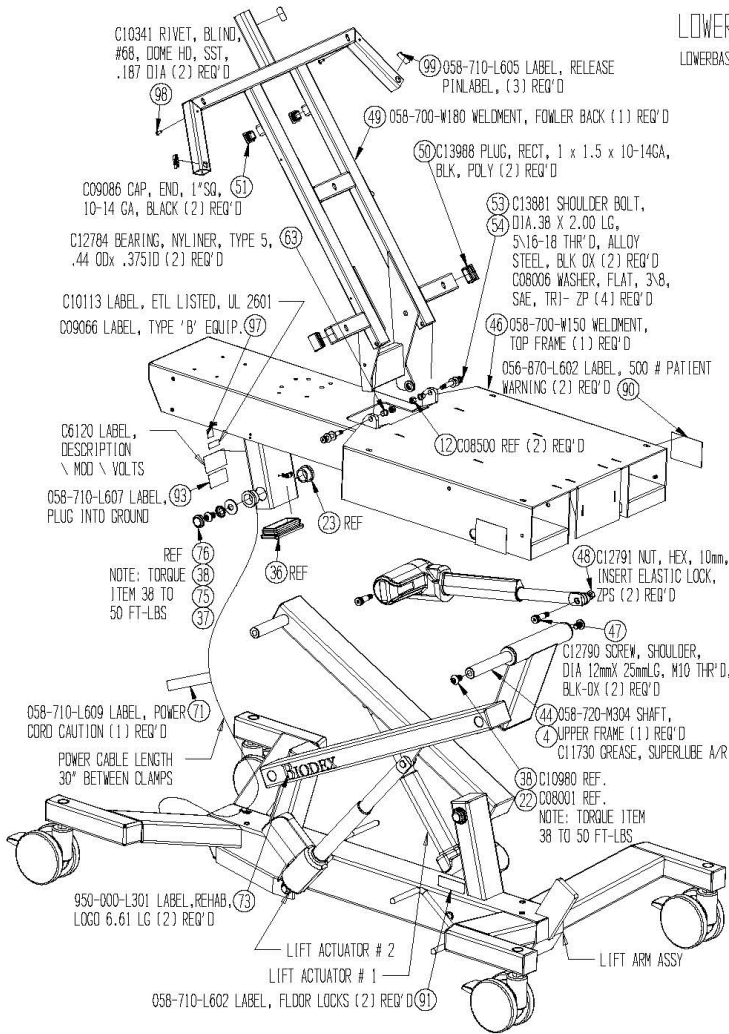

## LOWER BASE ASSY

LOWERBASEASSY058-700-A115-01

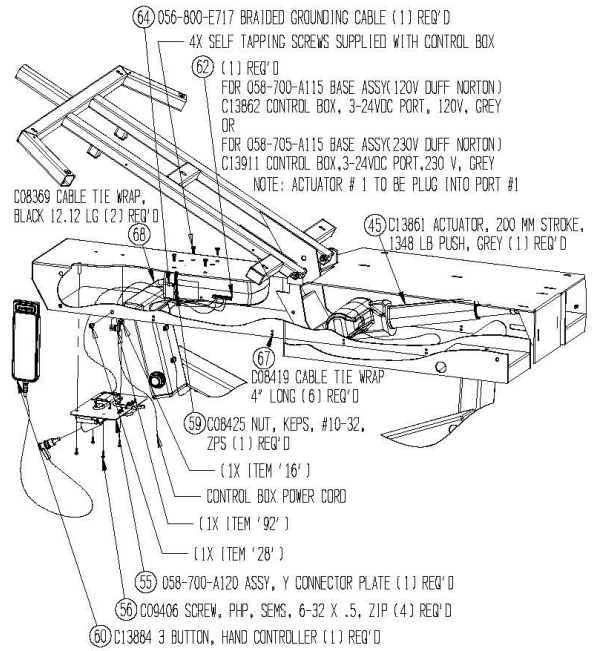

NOTES:  
 1-THIS DRAWING IS FOR THE FOLLOWING ASSY:  
 058-700-A115 LOWER BASE ASSY (120V DUFF NORTON)  
 058-705-A115 LOWER BASE ASSY (230V DUFF NORTON)



# FOOT SWITCH ASSY FOR TIMOTION ACTUATORS

FOOTSWITCHASSY058-741-A000-A

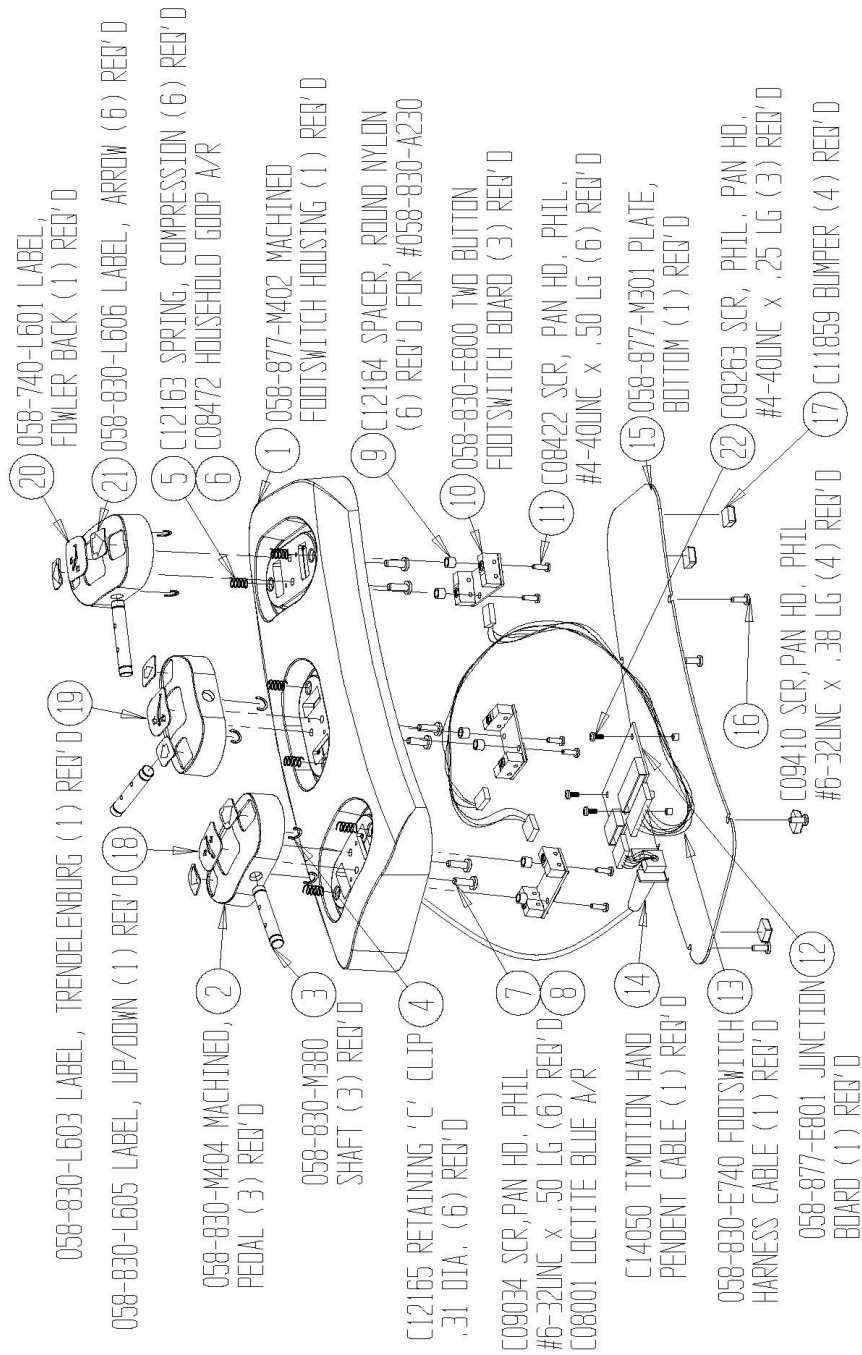

# HEAD REST ASSY

HEADREST ASSY 058-738-A000-A

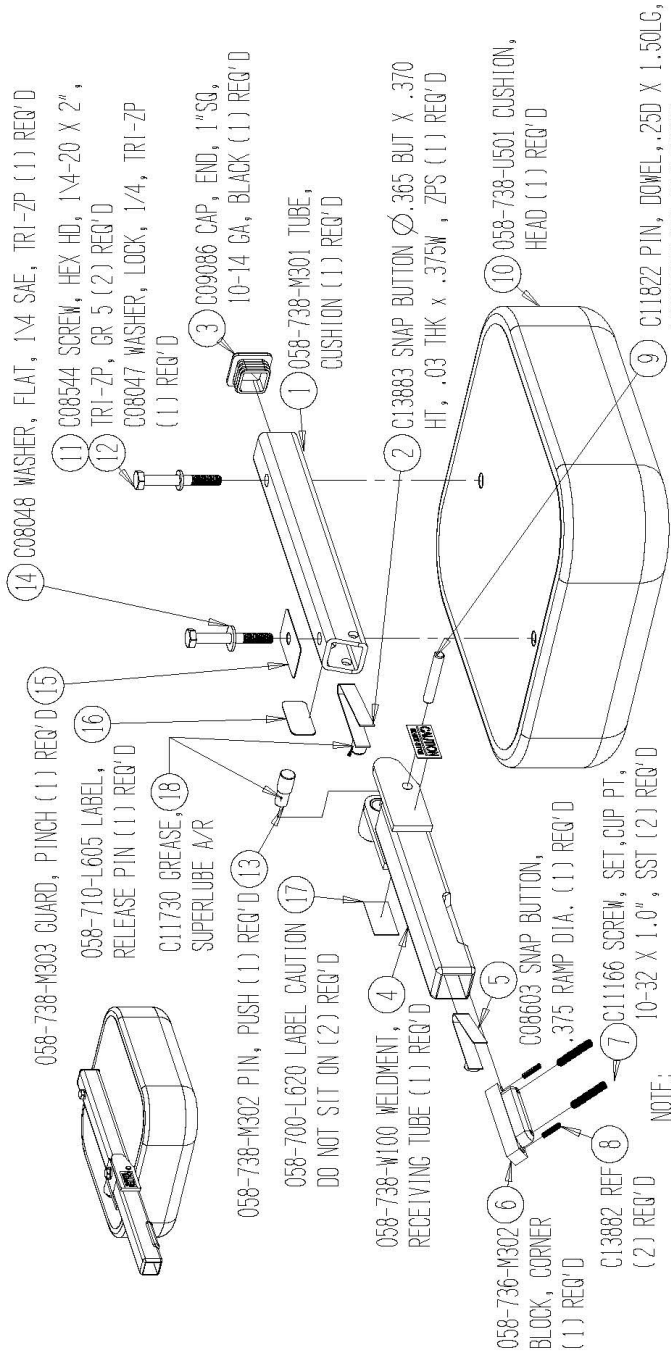

NOTE:  
ADJUST SET SCREWS SO THAT CORNER BLOCK IS POSITIONED SO THAT IT SLIDES INTO RECEIVING TUBE ON THE TABLE FOWLER BACK FRAME WITH MIN. AMOUNT OF PLAY

# PAPER DISPENSER ASSY

PAPERDISASSY058-611-A000-A

REMOVE SCREWS 1/4-20HEX HD. FROM  
BOTTOM OF CUSHION. ALIGN HOLE IN MNTG.  
BRKT. WITH HOLES IN CUSHION. REUSE SCREWS  
TO MOUNT BRACKETS

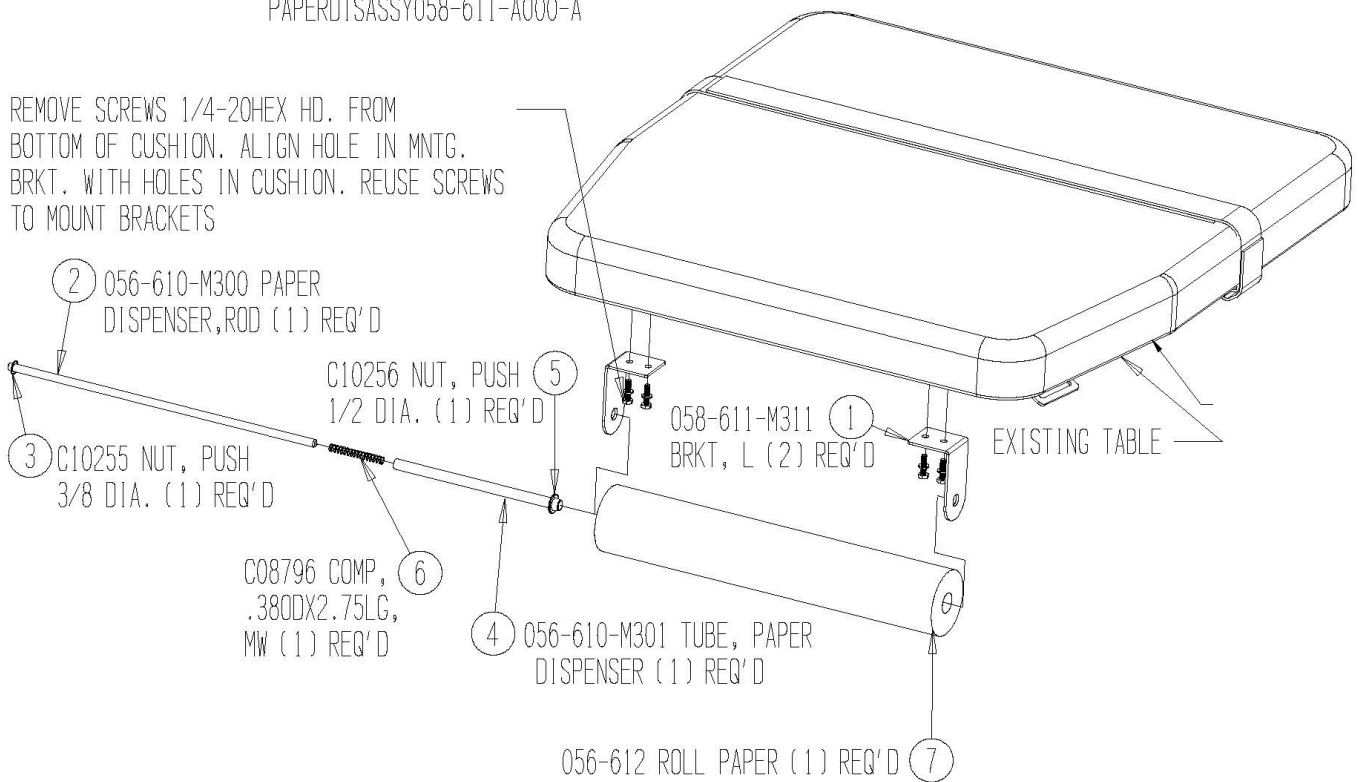



# SIDE RAIL ASSY

SIDERAILASSY 058-633-A000-B

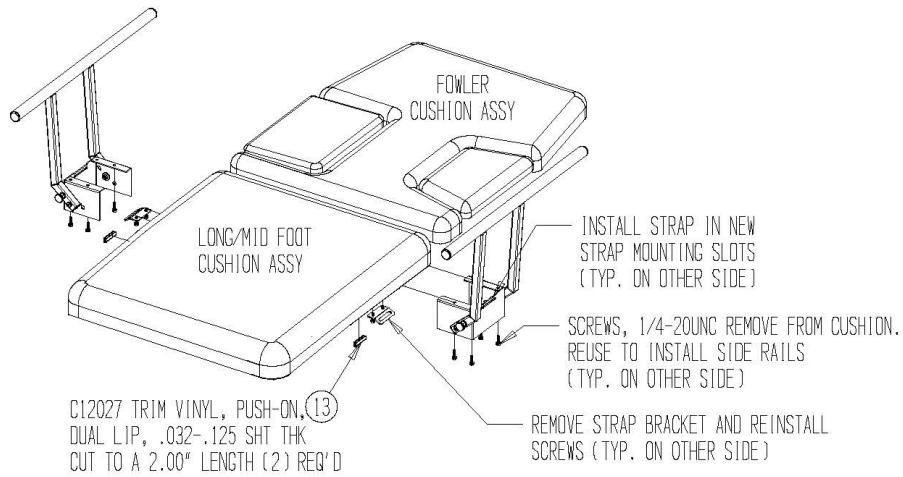
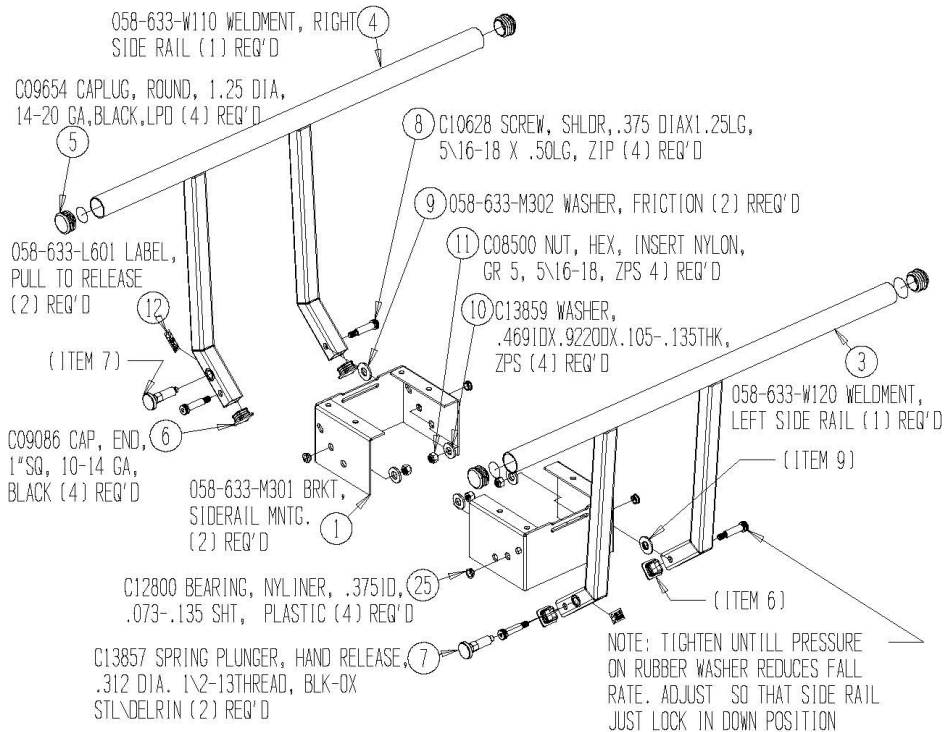

# ARM BOARD ASSY

ARMBDASSY058-736-A000-A

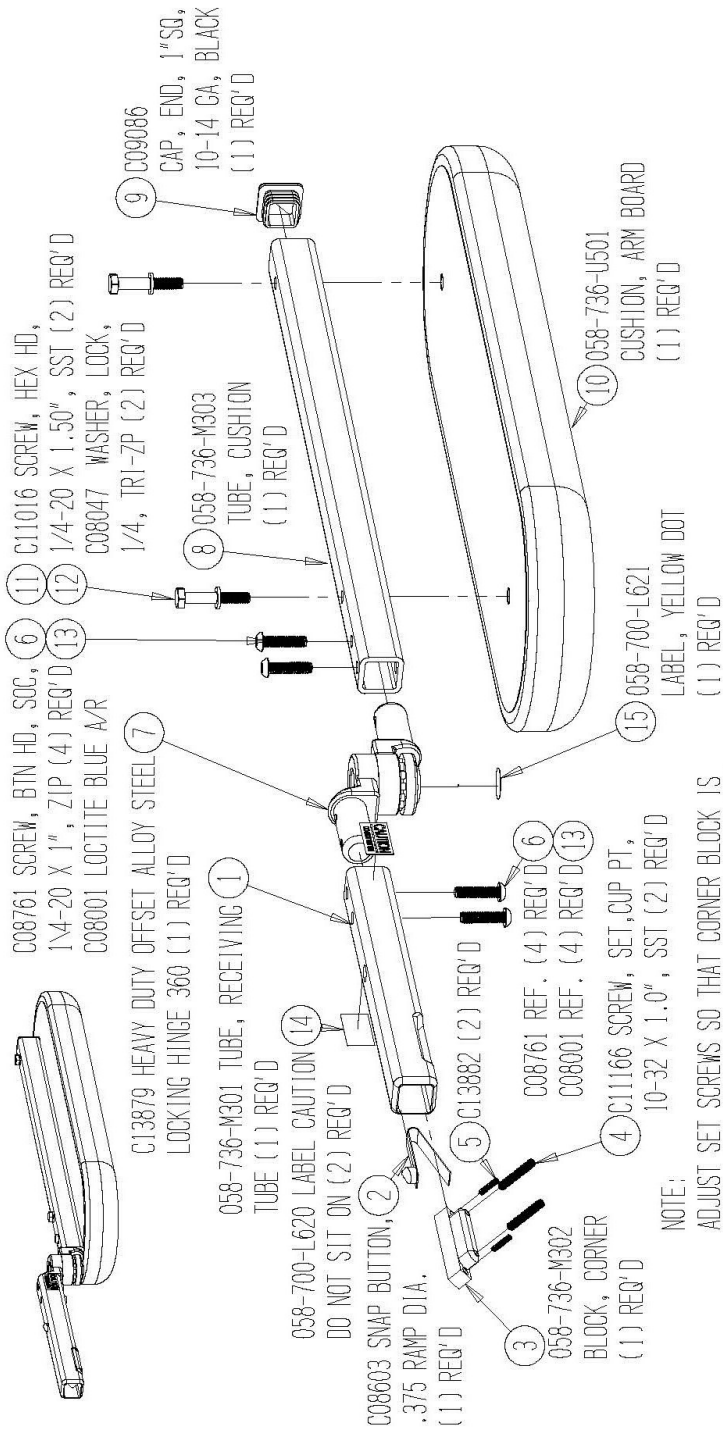

NOTE:  
 ADJUST SET SCREWS SO THAT CORNER BLOCK IS POSITIONED SO THAT IT SLIDES INTO RECEIVING TUBE ON THE TABLE FOWLER BACK FRAME WITH MIN. AMOUNT OF PLAY