

NOTES:

MATERIAL:
STEEL WITH 2.0mm LEAD
EQUIVALENCE

PAD PRINT COLOR:
2.0mm LEAD
EQUIVALENCE GLASS

FRAME COLOR:
TAN

NOT TO SCALE

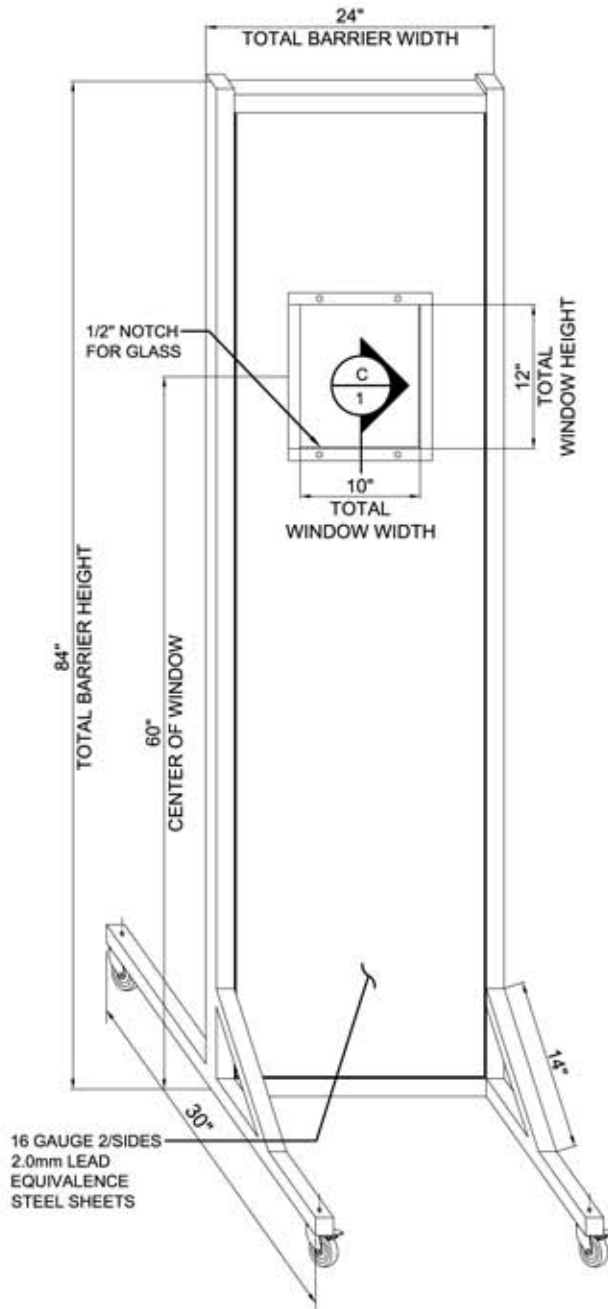

(A)
1 BARRIER ELEVATION

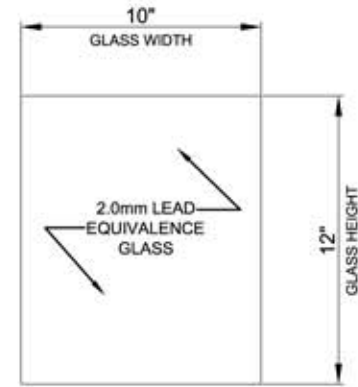

(B)
1 GLASS ELEVATION

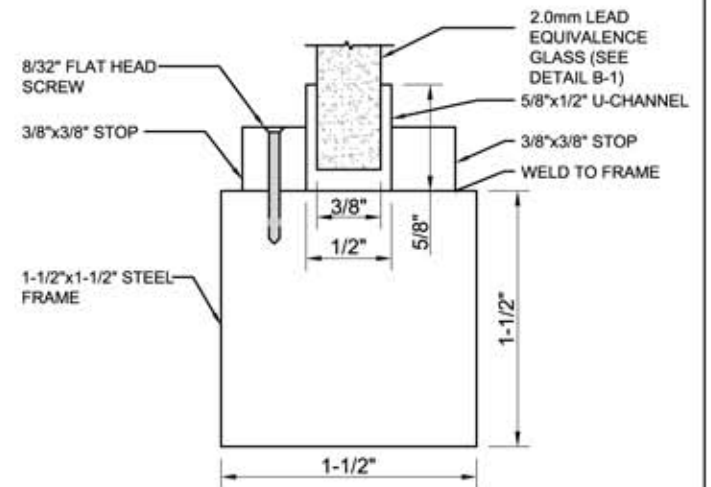

(C)
1 SECTION AT FRAME

	DWG No.	LB-2484	Rev.
	P/N:	LB-2484	
	DESC.	Opaque Mobile Leaded Barrier 24 in. x 84 in	