

vacuubrand

Technology for Vacuum Systems

Instructions for use

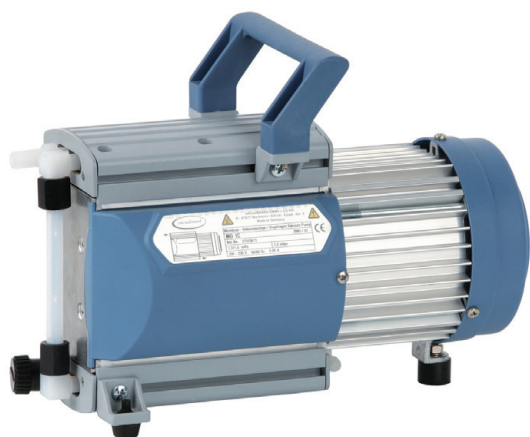

MD 1C
MD 1C + AK + EK
MD 1C VARIO-SP

Chemistry diaphragm pumps



Dear customer,

Your VACUUBRAND diaphragm pumps are designed to provide you with many years of trouble-free service with optimal performance. Our many years of practical experience allow us to provide a wealth of application and safety information. Please read these instructions for use before the initial operation of your pump.

VACUUBRAND diaphragm pumps combine our many years of experience in design, construction and practical operation, with the latest developments in material and manufacturing technology.

Our quality maxim is the "zero defect" principle:

Every diaphragm pump, before leaving our factory, is tested intensively, including an endurance run of 14 hours. Any faults, even those which occur rarely, are identified and can be eliminated immediately.

After completion of the endurance run, every pump is tested, and must achieve specifications before shipment.

We are committed to providing our customers only pumps that meet this high quality standard.

While our pumps cannot eliminate all of your work, we design, manufacture and test them to ensure that they will be an effective and trouble-free tool to assist you in that work.

Yours,

VACUUBRAND GMBH + CO KG

After sales service:

Contact your local dealer or call +49 9342 808-5500.

Trademark index:

VACUU·LAN® (US-Reg.No 3,704,401), VACUU·BUS®, VACUU·CONTROL®, VACUU·SELECT® (US-Reg.No 5,522,260), VARIO® (US-Reg.No 3,833,788), VACUUBRAND® (US-Reg.No 3,733,388), VACUU·VIEW®, GREEN VAC® (US-Reg.No. 4,924,553), VACUU·PURE® (US-Reg.No. 5,559,614) and also the shown company logos are registered trademarks of VACUUBRAND GMBH + CO KG in Germany and/or other countries.

DE

Achtung: Die vorliegende Betriebsanleitung ist nicht in allen EU-Sprachen verfügbar. Der Anwender darf die beschriebenen Geräte nur dann in Betrieb nehmen, wenn er die vorliegende Anleitung versteht oder eine fachlich korrekte Übersetzung der vollständigen Anleitung vorliegen hat. Die Betriebsanleitung muss vor Inbetriebnahme der Geräte vollständig gelesen und verstanden werden, und alle geforderten Maßnahmen müssen eingehalten werden.

 "Sicherheitshinweise für Vakuumgeräte"

EN

Attention: This manual is not available in all languages of the EU. The user must not operate the device if he does not understand this manual. In this case a technically correct translation of the complete manual has to be available. The manual must be completely read and understood before operation of the device and all required measures must be applied.

 "Safety instructions for vacuum equipment"

FR

Attention: Le mode d'emploi présent n'est pas disponible dans toutes les langues d'Union Européenne. L'utilisateur ne doit mettre le dispositif en marche que s'il comprend le mode d'emploi présent ou si une traduction complète et correcte du mode d'emploi est sous ses yeux. Le dispositif ne doit pas être mis en marche avant que le mode d'emploi ait été lu et compris complètement et seulement si le mode d'emploi est observé et tous les mesures demandées sont prises.

 «Avis de sécurité pour des dispositifs à vide»

BG

Внимание: Тези инструкции не са преведени на всички езици от ЕО. Потребителят не бива да работи с уреда, ако не разбира инструкциите за ползване. В този случай е необходимо да бъде предоставен пълен технически превод на инструкциите за ползване. Преди работа с уреда е задължително потребителят да прочете изцяло инструкциите за работа.

 "Указания за безопасност за вакуумни уреди"

CN

注意：该操作手册不提供所有的语言版本。操作者在没有理解手册之前，不能操作该设备。在这种情况下，需要有一个整个操作手册技术上正确的翻译。在操作该设备前，必须完全阅读并理解该操作手册，必须实施所有需要的测量。

 真空设备的安全信息

CZ

Upozornění :Tento návod k použití není k dispozici ve všech jazycích Evropské unie. Uživatel není oprávněn požit přístroj pokud nerozumí tomuto návodu. V takovém případě je nutno zajistit technicky korektní překlad manuálu do češtiny. Návod musí být uživatelem prostudován a uživatel mu musí plně porozumět před tím než začne přístroj používat. Uživatel musí dodržet všechna příslušná a požadovaná opatření.

 "Bezpečnostní upozornění pro vakuové přístroje".

DA

Bemærk: Denne manual foreligger ikke på alle EU sprog. Brugeren må ikke betjene apparatet hvis manualen ikke er forstået. I det tilfælde skal en teknisk korrekt oversættelse af hele manual stilles til rådighed. Manual skal være gennemlæst og forstået før apparatet betjenes og alle nødvendige forholdsregler skal tages.

 »Sikkerhedsregler for vakuumudstyr«

EE

Tähelepanu! Käesolev kasutusjuhend ei ole kõigis EL keeltes saadaval. Kasutaja ei tohi seadet käsitseda, kui ta ei saa kasutusjuhendist aru. Sel juhul peab saadaval olema kogu kasutusjuhendi tehniliselt korrektne tõlge. Enne seadme kasutamist tuleb kogu juhend läbi lugeda, see peab olema arusaadav ning kõik nõutud meetmed peavad olema rakendatud.

 "Ohutusnõuded vaakumseadmetele"

ES

Atención: Este manual no está disponible en todos los idiomas de UE. El usuario no debe manejar el instrumento si no entiende este manual. En este caso se debe disponer de una traducción técnicamente correcta del manual completo. El manual debe ser leído y entendido completamente y deben aplicarse todas las medidas de seguridad antes de manejar el instrumento.

 "Notas sobre la seguridad para equipos de vacío"

FI

Huomio: Tämä käyttöohje ei ole saatavilla kaikilla EU:n kielillä. Käyttäjä ei saa käyttää laitetta, jos hän ei ymmärrä tätä ohjekirjaa. Tässä tapauksessa on saatavilla oltava teknisesti oikein tehty ja täydellinen ohjekirjan käännös. Ennen laitteen käyttöä on ohjekirja luettava ja ymmärrettävä kokonaan sekä suoritettava kaikki tarvittavat valmistelut ja muut toimenpiteet.

 "Vakuumlaitteen turvallisuustiedot"

GR

Προσοχή! : Οι οδηγίες αυτές δεν είναι διαθέσιμες σε όλες τις γλώσσες της Ευρωπαϊκής Ένωσης. Ο χρήστης δεν πρέπει να θέσει σε λειτουργία την συσκευή αν δεν κατανοήσει πλήρως τις οδηγίες αυτές. Σε τέτοια περίπτωση ο χρήστης πρέπει να προμηθευτεί ακριβή μετάφραση του βιβλίου οδηγιών. Ο χρήστης πρέπει να διαβάσει και να κατανοήσει πλήρως τις οδηγίες χρήσης και να λάβει όλα τα απαραίτητα μέτρα πριν θέσει σε λειτουργία την συσκευή.

 "Υποδείξεις ασφάλειας για αντλίες κενού"

HR

Pažnja: ove upute ne postoje na svim jezicima Europske Unije. Korisnik nemora raditi sa aparatom ako ne razumije ove upute. U tom slučaju tehnički ispravni prijevod cijelih uputstava mora biti na raspolaganju. Uputstva moraju biti cijela procitana i razumljiva prije rada sa aparatom i sve zahtijevane mjere moraju biti primjenjene.

 "Sigurnosne napomene za vakuumske uređaje"

HU

Figyelem! Ez a kezelési utasítás nem áll rendelkezésre az EU összes nyelvén. Ha a felhasználó nem érti jelen használati utasítás szövegét, nem üzemeltetheti a készüléket. Ez esetben a teljes gépkönyv fordításáról gondoskodni kell. Üzembe helyezés előtt a kezelőnek végig kell olvasnia, meg kell értenie azt, továbbá az üzemeltetéshez szükséges összes mérést el kell végeznie.

 "A vákuum-készülékekkel kapcsolatos biztonsági tudnivalók"

IT

Attenzione: Questo manuale non è disponibile in tutte le lingue della Comunità Europea (CE). L'utilizzatore non deve operare con lo strumento se non comprende questo manuale. In questo caso deve essere resa disponibile una traduzione tecnicamente corretta del manuale completo. Il manuale deve essere completamente letto e compreso prima di operare con lo strumento e devono essere applicati tutti gli accorgimenti richiesti.

 "Istruzioni di sicurezza per apparecchi a vuoto"

JP

注意：この取扱説明書はすべての言語で利用可能ではありません。もしこの取扱説明書を理解できないならば、ユーザーは装置を操作してはなりません。この場合、技術的に正しい翻訳がなされた完全なマニュアルを用意しなければなりません。装置を作動する前にマニュアルを完全に読み、そして理解されなくてはなりません。そして、すべての要求される対策を講じなければなりません。

 真空装置を安全に取り扱うために

KR

주의 : 이 매뉴얼은 모든 언어로 번역되지는 않습니다. 만약 이 매뉴얼의 내용을 충분히 인지하지 못했다면 기기를 작동하지 마십시오. 매뉴얼의 내용을 기술적으로 정확하게 번역한 경우에 이용하십시오. 기기를 사용하기 전에 이 매뉴얼을 충분히 읽고 이해하고 모든 요구되는 사항들을 적용해야 합니다.

 진공 장비에 대한 안전 정보

LT

Dėmesio: šis vadovas nėra pateikiamas visomis ES kalbomis. Naudotojui draudžiama eksploatuoti įtaisą, jeigu jis nesupranta šio vadovo. Tokiu atveju reikia turėti viso vadovo techniškai taisyklingą vertimą. Vadovą būtina visą perskaityti ir suprasti pateikiamas instrukcijas prieš pradėdant eksploatuoti įtaisą, bei imtis visų reikiamų priemonių.

 "Vakuuminės įrangos saugos informacija"

LV

Uzmanību: Lietotāja instrukcija nav pieejama visās ES valodās. Lietotājs nedrīkst lietot iekārtu, ja viņš nesaprot lietotāja instrukcijā rakstīto. Šādā gadījumā, ir nepieciešams nodrošināt tehniski pareizu visas lietotāja instrukcijas tulkojumu. Pirms sākt lietot iekārtu, un, lai izpildītu visas nepieciešamās prasības, iekārtas lietotāja instrukcija ir pilnībā jāizlasa un jāsaprot.

 "Vakuuma iekārtu drošības noteikumi"

NL

Attentie: Deze gebruiksaanwijzing is niet in alle talen van de EU verkrijgbaar. De gebruiker moet niet met dit apparaat gaan werken als voor hem/haar de gebruiksaanwijzing niet voldoende duidelijk is. Bij gebruik van deze apparatuur is het noodzakelijk een technisch correcte vertaling van de complete gebruiksaanwijzing te hebben. Voor het in gebruik nemen van het apparaat moet de gebruiksaanwijzing volledig gelezen en duidelijk zijn en dienen alle benodigde maatregelen te zijn genomen.

 "Veiligheidsvoorschriften voor vacuümapparaten"

PL

Uwaga!! Ta instrukcja nie jest dostępna we wszystkich językach Unii Europejskiej. Użytkownik nie może rozpocząć pracy z urządzeniem dopóki nie przeczytał instrukcji i nie jest pewien wszystkich informacji w niej zawartych. Instrukcja musi być w całości przeczytana i zrozumiana przed podjęciem pracy z urządzeniem oraz należy podjąć wszystkie niezbędne kroki związane z prawidłowym użytkowaniem.

 "Wskazówki bezpieczeństwa do urządzeń próżniowych"

PT

Atenção: Este manual não está disponível em todas as línguas da UE. O usuário não deve utilizar o dispositivo, se não entender este manual. Neste caso, uma tradução tecnicamente correta do manual completo tem de estar disponível. O manual deve ser lido e entendido completamente antes da utilização do equipamento e todas as medidas necessárias devem ser aplicadas.

 "Informação de Segurança para Equipamento que funciona a Vácuo"

RO

Atentie: Acest manual nu este disponibil in toate limbile EU. Utilizatorul nu trebuie sa lucreze cu aparatul daca nu intelege manualul. Astfel, va fi disponibile o traducere corecta si completa a manualului. Manualul trebuie citit si inteles in intregime inainte de a lucra cu aparatul si a luat toate masurile care se impun.

 "Instrucțiuni de siguranță pentru aparatele de vidare"

RU

Внимание: Эта инструкция по эксплуатации не имеется на всех языках. Потребителю не дозволено эксплуатировать данный прибор, если он не понимает эту инструкцию. В этом случае нужен технически правильный перевод полной инструкции. Прежде чем использовать этот прибор, необходимо полностью прочитать и понять эту инструкцию и принять все необходимые меры.

 "Указания по технике безопасности при работе с вакуумными устройствами"

SE

Varning: Denna instruktion är inte tillgänglig på alla språk inom EU. Användaren får inte starta utrustningen om hon/han inte förstår denna instruktion. Om så är fallet måste en tekniskt korrekt instruktion göras tillgänglig. Instruktionen måste läsas och förstås helt före utrustningen tas i drift och nödvändiga åtgärder göres.

 "Säkerhetsinformation för vakuumpårustning"

SI

Pozor: Ta navodila niso na voljo v vseh jezikih EU. Uporabnik ne sme upravljati z napravo, če ne razume teh navodil. V primeru nerazumljivosti mora biti na voljo tehnično pravilen prevod. Navodila se morajo prebrati in razumeti pred uporaba naprave, opravljene pa moraja biti tudi vse potrebne meritve.

 "Varnostni nasveti za vakuumske naprave"

SK

Upozornenie: Tento manuál nie je k dispozícii vo všetkých jazykoch EÚ. Užívateľ nesmie obsluhovať zariadenie, pokiaľ nerozumie tomuto manuálu. V takomto prípade musí byť k dispozícii technicky správny preklad celého manuálu. Pred obsluhou zariadenia je potrebné si prečítať celý manuál a porozumieť mu, a musia byť prijaté všetky opatrenia.

 "Bezpečnostné pokyny pre vákuové zariadenia"

TR

Dikkat : Bu kullanım kitabı, tüm dillerde mevcut değildir. Kullanıcı, bu kullanım kitabını anlayamadıysa cihazı çalıştırmamalıdır. Bu durumda, komple kullanım kitabının, teknik olarak düzgün çevirisinin bulunması gerekir. Cihazın çalıştırılmasından önce kullanım kitabının komple okunması ve anlaşılması ve tüm gerekli ölçümlerin uygulanması gerekir.

 "Vakumlu cihazlar için güvenlik uyarıları"

Contents

Safety information!	9
Important information!	9
General information	11
Intended use.....	11
Setting up and installing the equipment	12
Ambient conditions	15
Operating conditions	16
Safety during operation	17
Maintenance and repair.....	20
⊕ Important information: Equipment marking (ATEX).....	23
Technical data	25
Gas inlet temperatures	27
Wetted parts	28
Abbreviations.....	29
Pump parts	29
Replacing the device fuse (only MD 1C C/US)	34
Replacing the fuse on the circuit board (only MD 1C VARIO-SP)	35
Use and operation	37
Installation	37
Vacuum connection (inlet)	38
Separator (AK) at the inlet.....	39
Connecting the outlet	40
Exhaust waste vapor condenser (EK) at the outlet	41
Electrical connection	43
Controlling the MD 1C VARIO-SP	45
During operation.....	50
Important notes regarding the use of gas ballast	52
In case of condensation	54
Shutdown & storage	55
Accessories	55
Troubleshooting	57
Replacing diaphragms and valves	58
Checking diaphragms and valves	61
Replacing the diaphragm	65
Replacing the valves and assembling the pump heads	68

Assembling the connecting hose (MD 1C + AK + EK)..... 72

Replacing the overpressure safety relief device 74

Spare parts MD 1C + AK + EK 76

Repair - Maintenance - Return - Calibration..... 77

Warranty 78

Health and safety clearance form 79

Declarations and certificates..... 80

Safety information!

Important information!

WARNING

- ☞ Keep this manual complete and accessible to personnel at all times!
- ☞ Read this manual carefully before installing or operating the equipment. Observe the instructions contained in this manual.
- ☞ Do not modify the equipment without authorization.

NOTICE

This manual is an integral part of the equipment described therein. It describes the safe and proper use of the vacuum pump.

Make operating personnel aware of dangers arising from the pump and the pumped substances.

VACUUBRAND disclaims any liability for inappropriate use of these pumps and for damage from failure to follow instructions contained in this manual.

This manual is only to be used and distributed in its complete and original form. It is strictly the users' responsibility to check carefully the validity of this manual with respect to his product.

Manual-no.: 20901056

The following signal word panels and safety symbols are used throughout this manual:



This is the safety alert symbol. It is used to alert you to potential personal injury hazards. Obey all safety messages that follow this symbol to avoid possible injury or death.



➔ DANGER indicates a hazardous situation which, if not avoided, will result in death or serious injury.



☞ WARNING indicates a hazardous situation which, if not avoided, could result in death or serious injury.



• CAUTION indicates a hazardous situation which, if not avoided, could result in minor or moderate injury.



NOTICE is used to address practices not related to personal injury.



Caution! Hot surface!



Disconnect equipment from AC power.



Electronic components must not be disposed of in the domestic waste at the end of their service life. Used electronic devices contain harmful substances that can cause damage to the environment or human health. End users are legally obliged to take used electric and electronic devices to a licensed collection point.

Formatting used in this manual:

Note: The signal word panels in all sections of this manual always refer to all paragraphs of the same format (➔ / ☞ / • / plain text) following each signal word panel.

The document "Safety information for vacuum equipment" is part of this manual! Read the "Safety information for vacuum equipment" and observe the instructions contained therein!

General information

NOTICE

Remove all packing material from the packing box. Remove the product from its packing-box and retain all packaging until the equipment is inspected and tested. Remove the protective caps from the inlet and outlet ports and retain for future use. Inspect the equipment promptly and carefully.

If the equipment is damaged, notify the supplier and the carrier in writing within three days. Retain all packing material for inspection. State the item number of the product together with the order number and the supplier's invoice number. Failure to check and give notice of damage will void any and all warranty claims for those deficiencies.

Replace the protective caps, if the equipment is not used immediately. Store the equipment in dry and non-corrosive conditions (see also „Technical data“, pg. 25).

WARNING

☞ **Do not use any damaged equipment.**

CAUTION

- Use the mounted handle or the recessed grips when moving the pump.

Intended use

WARNING

☞ Do not use the pump or any system parts on humans or animals.

☞ Ensure that the individual components are only connected, combined and operated according to their design and as indicated in the instructions for use. Use only **original manufacturer's parts and accessories**. Otherwise the safety and performance of the equipment, as well as the electromagnetic compatibility of the equipment might be reduced.

The CE mark or the cTÜVus mark may be voided if not using original manufacturer's spare parts.

☞ Comply with all notes on correct vacuum and electrical connections; see section „Use and operation“, pg. 37.

- ☞ Do not use the pump to generate pressure.
- ☞ The pumps are designed for **ambient temperatures** during operation between +50°F and +104°F (+10°C and +40°C). Periodically check maximum temperatures if installing the pump in a cabinet or a housing. Make sure ventilation is adequate to maintain recommended operating temperature. Install an external automatic ventilation system if necessary. If pumping hot process gases, make sure that the maximum permitted gas inlet temperature is not exceeded. The maximum permitted gas inlet temperature depends on several parameters like inlet pressure and ambient temperature (see „Technical data“, pg. 25).
- ☞ Particles and dust must not enter the pump.
- ☞ Do not pump liquids.

CAUTION

- Ensure that the pump is chemically resistant to the pumped substances prior to operation.

NOTICE

Use the equipment **only as intended**, that is, for generation of vacuum in vessels designed for that purpose. Any other use will automatically invalidate all warranty and liability claims. Remain aware of safety and risks.

Setting up and installing the equipment

DANGER

- ➔ Equipment must be connected only to a **suitable electrical supply** and a suitable ground point. As such, the plug (pumps with AC motor) must be plugged into an outlet that is properly grounded. Provide a slow blow fuse according to the electrical supply (see „Technical data“, pg. 25). Failure to connect the motor to ground may result in deadly electrical shock.
- ➔ Pumps with 24 V DC motor: The pump has no on/off switch. The user has to provide a suitable line disconnect.

- ➔ The supply cable (pumps with AC motor) may be fitted with a molded European IEC plug or a plug suitable for your local electrical supply. The cable contains wires color coded as follows: green or green and yellow: ground; blue or white: neutral; brown or black: hot.

⚠ WARNING

- ☞ Due to the high compression ratio, the pump may generate overpressure at the outlet. Check pressure compatibility with system components (e.g., exhaust pipeline or exhaust valve) at the outlet.
- ☞ Do not permit any **uncontrolled pressurizing**. Make sure that the exhaust pipeline cannot become blocked. If there is an exhaust isolation valve, make sure that you cannot operate the equipment with the valve closed to avoid a **risk of bursting!**
- ☞ Keep the electrical power cord away from heated surfaces.
- ☞ Keep the electrical power cord away from hot surfaces.

⚠ CAUTION

- Provide a firm, level platform for the equipment. Check that the system which you are going to evacuate is mechanically stable. Check that all fittings are secure. Ensure a stable position of the pump without any mechanical contact other than the pump feet.
- Comply with **maximum permissible pressures** at inlet and outlet and with **maximum permissible pressure differences** between inlet and outlet. See section „Technical data“, pg. 25. Do not operate the pump with overpressure at the inlet.
- Avoid overpressure of more than 17.5 psi absolute (1.2 bar absolute) in the event that gas or inert gas is connected to the pump, to the gas ballast or to a venting valve.
- **Note:** Flexible elements will shrink when evacuated.
- Connect hoses gas tight at inlet and outlet of the pump.
- Ensure that no foreign objects can be drawn into the pump.



- Risk of burns from hot surfaces.
In case of failure the pump surface can heat up to temperatures $> 105\text{ }^{\circ}\text{C}$. Provide a suitable contact guard to protect yourself from accidental contact with hot surfaces.
Ensure the cooling-down of the pump prior to any further work. Wear adequate personal protective equipment, if necessary.
- Check the power source and the pump's rating plate to be sure that the power source and the equipment match in voltage, phase, and frequency.
- On pumps with a dual-voltage motor (100-120V / 200-230V; 50/60 Hz), check that the voltage selection switch is set correctly. Do not change the setting of the voltage selection switch while the pump is connected to AC power. Unplug the pump before setting the voltage selection switch. **Note:** If the pump is switched on with wrong voltage selection, the motor may be damaged!
- Ensure that no liquids can flow on or into the pump motor when assembling or disassembling vacuum lines at the pump. Risk of corrosion and/or short circuit!
- Ensure that the **coolant outlet pipe** is always free and that it cannot get blocked. If installing an optional coolant valve, it must always be in the supply line of the exhaust waste vapor condenser.

NOTICE

Make sure ventilation is adequate to maintain recommended operating temperature. Keep a minimum distance of 2 in (5 cm) between the cooling fan and surrounding items (e.g., housing, walls, etc.), or else install an external automatic ventilation system. Clean fan guard grill if necessary to avoid a reduction of ventilation.

The mains plug is a disconnecting device to separate the pump from the supply voltage. Ensure that the mains plug is easily accessible at all times to allow the separation of the device from the power supply.

Use only hoses at the inlet and outlet of the pump with an inner diameter at least as large as the diameter of the pump's tubing (to avoid overpressure at the outlet, and reduction of pumping speed at the inlet).

Allow the equipment to equilibrate to ambient temperature if you bring it from cold environment into a room prior to operation. Notice if there is water condensation on cold surfaces.

Secure coolant hoses at the hose nozzles (e.g., with hose clamp) to prevent their accidental slipping.

Comply with all **applicable and relevant safety requirements** (regulations and guidelines). **Implement the required actions and adopt suitable safety measures.**

Ambient conditions

! DANGER

- ➔ Do not reach for this product if it has fallen into liquid. There is a risk of deadly electrical shock. Unplug the system immediately.

! WARNING

- ☞ Do not use this product in an area where it can fall or be pulled into water or other liquids.

! CAUTION

- This product may only be used indoors in a non-explosive atmosphere, and in a dry environment. Adopt suitable measures in case of differences from recommended conditions, e.g., installation in higher altitudes (risk of insufficient cooling), conductive pollution or external condensation on the pump.
- Do not operate this product near flames.

NOTICE

To the best of our knowledge the equipment is in compliance with the requirements of the applicable EC-directives and harmonized standards (see "Declaration of Conformity") with regard to design, type and model. Standard EN 61010-1 gives in detail the conditions under which the equipment can be operated safely (see also IP degree of protection, „Technical data“, pg. 25).

Operating conditions

DANGER

- ➔ These pumps are not approved for operation in potentially explosive atmospheres. **Do not operate the pumps in potentially explosive atmospheres.**
- ➔ Pumps **without the "Ex" mark on the rating plate are not approved for the pumping of potentially explosive atmospheres. Do not pump potentially explosive atmospheres** with those pumps.
- ➔ Pumps **bearing the "Ex" mark on their rating plates are approved for the pumping of potentially explosive atmospheres** according to their ATEX classification imprinted on their rating plate, but they are **not approved for operation in potentially explosive atmospheres** (see section „Ex Important information: Equipment marking (ATEX)“, pg. 23).
- ➔ The pumps are **not suitable** to pump any of the substances listed below.
Do not pump:
 - **unstable substances**
 - substances which react explosively under **impact** (mechanical stress) without air
 - substances which react explosively when being exposed to **elevated temperatures** without air,
 - substances subject to **auto-ignition**,
 - substances which are **flammable without air**
 - **explosive substances.**
- ➔ The pumps are **not approved** for operation below ground. **Do not operate** the pump **below ground.**

CAUTION

- **Do not pump** substances which may form **deposits** inside the pump. The pumps are not suitable for pumping substances which may form deposits inside the pump. Deposits and condensate in the pump may lead to increased temperatures even to the point of exceeding the maximum permitted temperatures.

- Check the inlet and outlet of the pump, if there is a danger of forming **deposits** inside the pump, e.g., in the pump chambers (the pump chamber is the part between diaphragm and head cover. See section „Replacing diaphragms and valves“, pg. 58). Inspect the pump chambers regularly and clean if necessary.
- **Consider interactions and chemical reactions of the pumped media.** Ensure that the materials of the pump's wetted parts are compatible with the pumped substances, see section „Technical data“, pg. 25. When changing the substances pumped, we recommend purging the pump with air or inert gas prior to changing the pumped media. Purging the pump will pump out residues and it will reduce the possibility of reactions of the pumped substances with each other and with the pump's materials.

Safety during operation



- ➔ Adopt suitable measures to prevent the release of dangerous, toxic, explosive, corrosive, noxious or polluting fluids, vapors and gases. To prevent any emission of such substances from the pump outlet, install an appropriate collecting and disposal system and take protective action for pump and environment.
- ➔ You must take suitable precautions to prevent any formation of explosive mixtures in the pump chamber or at the outlet of the pump. In case, e.g., of a diaphragm failure, mechanically generated sparks, hot surfaces or static electricity may ignite these mixtures. Use inert gas for gas ballast or venting, if necessary.
- ➔ Drain appropriately or otherwise remove any potentially explosive mixtures at the outlet of the pump, or dilute them to non-explosive concentrations.
- ➔ Never operate this pump if it has a damaged cord or plug.

 **WARNING**

- ☞ If the pump is not working properly, has been dropped or has fallen into water, contact your pump service provider.
- ☞ Prevent any part of the human body from coming into contact with vacuum.
- ☞ Make sure that the exhaust pipeline cannot become blocked.
- ☞ Check the overpressure safety relief device at the exhaust waste vapor condenser at appropriate intervals.
- ☞ Comply with applicable regulations when disposing of chemicals. Take into consideration that chemicals may be contaminated. Take adequate precautions to protect people from the effects of dangerous substances (chemicals, thermal decomposition products of fluoro-elastomers). Use appropriate protective clothing and safety goggles.
- ☞ Interruption of the pump (e.g., due to power failure), failure of connected components or of parts of the supply, or change in parameters must not be allowed to lead to dangerous conditions. In case of a diaphragm failure or in case of a leak in the manifold, pumped substances might be released into the environment or into the pump housing or motor.
Comply with all notes regarding proper use of the pumps, as well as operation and maintenance guidance.
- ☞ The residual **leak rate of the equipment** might render possible an exchange of gas, albeit extremely slight, between the environment and the vacuum system.
Adopt suitable measures to prevent contamination of the pumped substances or the environment.

 **CAUTION**

- Ensure that no parts of your clothing, hair or fingers can be caught or drawn in at the inlet of the pump. Never insert fingers or drop any other object into the inlet or outlet.
- Pumping at high inlet pressure may lead to overpressure at the gas ballast valve. Pumped gases or con-

densate might be expelled if the valve is open. If an inert gas supply is connected to the gas ballast, ensure that its inlet pipeline is not contaminated.



- Pay attention to the safety symbol "hot surfaces" on the equipment. Depending on operation conditions and ambient conditions dangers due to hot surfaces may arise. Hot parts may cause burns if touched. Adopt suitable measures to prevent any danger arising from hot surfaces. Ensure that hot surfaces of the pump do not cause burns. Provide a suitable contact guard if necessary.
- Risk of burns from hot surfaces.
In case of failure the pump surface can heat up to temperatures > 105 °C. Provide a suitable contact guard to protect yourself from accidental contact with hot surfaces.
Ensure the cooling-down of the pump prior to any further work. Wear adequate personal protective equipment, if necessary.
- Ensure that the **coolant outlet pipe** at the waste vapor condenser is always free and that it cannot get blocked.

NOTICE

Do not start the pump if the pressure difference between inlet and outlet exceeds 16 psi (1.1 bar) at maximum. Prevent the backpressure of gases and the backflow of condensates at the outlet.

Check the liquid level in the catchpots regularly and drain condensate in time to prevent overfilling.

Provide appropriate protective measures to allow for the possibility of failure and **malfunction**. The protective measures must also allow for the requirements of the respective application.

Pumps with AC motor:

In case of overload, the motor is shut down by a **self-hold thermal cutout** in the winding.

Note: Only manual reset is possible. Switch off the pump and disconnect from the power source.

Identify and eliminate the cause of failure. Wait approx. five minutes before restarting the pump.

CAUTION

- **Note:** In case of **supply voltage below 115 V**, the lock of the cutout might be impaired and the pump may restart on its own after sufficient cooling down. Take appropriate precautions, if an automatic restart of the pump may lead to a dangerous situation (e.g., switch off the pump and disconnect from the power source).

Pumps with DC motor:

A temperature sensor at the circuit board protects the motor of pumps with 24V DC motor. In case of excess temperature, the pump is switched off.

Note: Only manual reset is possible. Disconnect the pump from the power source. Identify and eliminate the cause of failure.

Maintenance and repair

NOTICE

In order to comply with laws (occupational, health and safety regulations, safety at work law and regulations for environmental protection) vacuum pumps, components and measuring instruments can only be returned when certain procedures (see section „Repair - Maintenance - Return - Calibration“, pg. 77) are followed.

Take advantage of our service seminars, which put special focus on the maintenance and repair of vacuum pumps. For details and for the online "Instructions for repair" manual see www.vacuubrand.com.

In normal use, the lifetime of the diaphragms and valves is typically 15,000 operating hours. Bearings have a typi-

cal durability of 40000 h. Motor capacitors have a typical durability in the range of 10000 to 40000 h depending strongly on operation conditions including ambient temperature, humidity or load.

! DANGER

➔ **Ensure that the pump cannot be operated accidentally. Never operate the pump if covers or other parts of the pump are disassembled.**



➔ **Switch off the pump. Disconnect the electrical power cord and wait five seconds** before starting maintenance to allow the capacitors to discharge.

➔ **Note:** The pump may be contaminated with process chemicals, which have been pumped during operation. Ensure that the pump is completely decontaminated before maintenance commences.

! WARNING

☞ Take adequate precautions to protect people from the effects of dangerous substances if contamination has occurred. Use appropriate protective clothing, safety goggles and protective gloves.

☞ **Wear parts have to be replaced regularly.**

☞ **Never operate a defective or damaged pump.**

☞ Check every motor capacitor regularly by measuring its capacity and estimating its time in operation. Replace old capacitors early enough to prevent a failure in operation. If an old motor capacitor fails, the capacitor may get hot. It may even melt or emit a flame, which could be **dangerous for persons and equipment in the vicinity**. The capacitors have to be replaced by an electrician.

☞ Vent the pump before starting maintenance. Isolate the pump and other components from the vacuum system. Allow sufficient cooling of the pump. Drain condensate, if applicable.

NOTICE

Clean polluted surface with a clean, slightly moistened cloth. To moisten the cloth we recommend water or mild soap.

Ensure that **maintenance** is done only by suitably trained and supervised technicians. Ensure that the maintenance technician is familiar with the safety procedures, which relate to the products processed by the pumping system. Only dismantle the pump as far as necessary.

Important information: Equipment marking (ATEX)

Only valid for products with ATEX marking. If the ATEX marking is shown on the rating plate of the respective product, VACUUBRAND GMBH + CO KG assures, that the device complies with the provisions of the directive 2014/34/EU. The applied harmonized standards are indicated in the EC Declaration of Conformity of the Machinery (see instructions for use).

VACUUBRAND equipment bearing the ATEX mark (see rating plate)

The classification according to ATEX is only valid for the inner part (wetted part, pumped gas or vapor) of the equipment. The equipment is not suitable for use in external, potentially explosive atmospheres (environment).

The overall category of the equipment depends on the connected components. If the connected components do not comply with the classification of the VACUUBRAND equipment, the specified category of the VACUUBRAND equipment is no longer valid.

Vacuum pumps and vacuum gauges in category 3 are intended for connection to equipment in which during normal operation explosive atmospheres caused by gases, vapors or mists normally don't occur; or, if they do occur, are likely to do so only infrequently and for a short period only. Equipment in this category ensures the requisite level of protection during normal operation.

The use of gas ballast or the operation of venting valves is only permitted if thereby explosive atmospheres normally don't occur in the interior of the equipment or, if they do occur, are likely to do so only infrequently and for a short period.

The pumps are marked with "X" (according to DIN EN ISO 80079-36:2016), i.e., restrictions of the operation conditions:

- The equipment is designated for an ambient and gas inlet temperature during operation of +10 to +40°C. Never exceed these ambient and gas inlet temperatures. If pumping / measuring gases which are not potentially explosive, extended gas inlet temperatures are permissible. See instructions for use, section “Gas inlet temperatures” or “Technical data”.

After any intervention at the equipment (e.g., repair / maintenance) the ultimate vacuum of the pump has to be checked. Only if the pump achieves its specified ultimate vacuum is the pump’s leak rate low enough to ensure that no explosive atmospheres will occur in the interior of the equipment.

After any intervention at the vacuum sensor, the leak rate of the equipment has to be checked.



Attention: This manual is not available in all languages of the EU. The user must not operate the device if he does not understand this manual. In this case a technically correct translation of the complete manual has to be available. The manual must be completely read and understood before operation of the device. All specified measures must be applied, or else must be replaced by equivalent measures at the user’s own risk.

Technical data

Type		MD 1C MD 1C + AK + EK	MD 1C VARIO-SP
ATEX approval if the ATEX marking is shown on the rating plate Inner part (pumped gases)		II 3/- G Ex h IIC T3 Gc X Internal Atm. only Tech.File: VAC-EX02	
Maximum pumping speed 50/60 Hz (ISO 21360)	cfm (m ³ /h)	0.77 / 0.88 ^(a) (1.3/ 1.5 ^(a))	1.1 (1.8)
Ultimate vacuum (absolute) without gas ballast	Torr (mbar)	1.5 (2)	1.5 ^(b) (2 ^(b))
Ultimate vacuum (absolute) with gas ballast	Torr (mbar)	3 (4)	3 ^(b) (4 ^(b))
Maximum permissible inlet pressure (absolute)	psi (bar)	16 (1.1)	
Maximum permissible outlet pressure (absolute)	psi (bar)	16 (1.1)	
Maximum pressure difference between inlet and outlet	psi (bar)	16 (1.1)	
Maximum permissible pressure (absolute) at gas ballast valve	psi (mbar)	17.5 (1.2)	
Permissible ambient tempera- ture storage / operation	°F (°C)	14 to 140 / 50 to 104 (-10 to +60 / +10 to +40)	
Permissible relative atmospher- ic moisture during operation (no condensation)	%	30 to 85	
Maximum permissible installation altitude above mean sea level	ft (m)	6500 (2000)	
Rated motor power	hp (kW)	0.01 (0.08)	0.086 (0.064)
No-load speed	rpm	1500 / 1800 ^(a)	0 - 2400 ^(c)
Maximum permissible range of supply voltage (±10%) Attention: Observe specifications of rating plate!		100-115 V~ 50/60 Hz 220-230 V~ 50/60 Hz 120 V~ 60 Hz	24 V DC safe extra low vol- tage (SELV) ^(d)

Type		MD 1C MD 1C + AK + EK	MD 1C VARIO-SP
Maximum rated current at:			
100-115 V~ 50/60 Hz	A	1.6 / 1.7	-
220-230 V~ 50/60 Hz	A	0.8 / 0.85	-
120 V~ 60 Hz	A	1.7	-
24 V DC	A	-	7
Motor protection		thermal cutout, manual reset ^(e) MD 1C C/US: additional fuse 250 V / 2,5 AT – 5x20	current limitation (temperature sensor on the circuit board) fuse 125 V / F 7 A – 2x7
Overvoltage category		II	-
Degree of protection IEC 60529		IP 40	IP 20
Degree of protection UL 50E		type 1	
Pollution degree		2	
Inlet		hose nozzle for tubing I.D. 3/8” (hose nozzle DN 10 mm)	
Outlet		hose nozzle for tubing I.D. 5/16” (hose nozzle DN 8 mm) MD 1C + AK + EK: hose nozzle for tubing I.D. 3/8” (hose nozzle DN 10 mm)	
Coolant connection (waste vapor condenser, only "AK + EK")		hose nozzle for tubing I.D. 1/4” - 5/16” (hose nozzle DN 6-8 mm)	
Maximum permissible pres- sure of coolant at waste vapor condenser (only "AK + EK")	psi (bar)	87 (absolute) (6 (absolute))	
Permissible range of coolant temperature (waste vapor condenser, only "AK + EK")	°F (°C)	5 to 68 (-15 to +20)	
Volume of catchpot (only "AK + EK")	quarts (ml)	0.52 (500)	
A-weighted emission sound pressure level ^(f) (uncertainty K_{pA} : 3 dB(A))		45	42
Weight approx. MD 1C	lbs. (kg)	17.4 (7.9)	9.3 (4.2)
MD 1C + AK + EK	lbs. (kg)	24.3 (11.0)	-

Type		MD 1C MD 1C + AK + EK	MD 1C VARIO-SP
Dimensions L x W x H approx.			
MD 1C	in (mm)	13.3 x 5.6 x 8.8 (338 x 142 x 223)	9.3 x 5.6 x 6.9 (235 x 143 x 175)
MD 1C + AK + EK	in (mm)	12.4 x 9.4 x 15.9 (316 x 239 x 405)	- -
Dimensions L x W x H without handle approx.			
MD 1C	in (mm)	13.3 x 5.6 x 6.9 (338 x 142 x 175)	- -

- (a) at 50/60 Hz
- (b) at 1500 rpm
- (c) running smoothly only at motor speeds higher than 200 rpm
- (d) The pump is designed for operation with safe extra low voltage. Accordingly only safe extra low voltage (SELV) may be connected to the voltage supply connections.
- (e) In case of supply voltage below 115 V, the lock of the cutout might be restricted.
- (f) Measurement according to EN ISO 2151:2004 and EN ISO 3744:1995 at 230 V / 50Hz or 1500 rpm (MD 1C VARIO-SP) and at ultimate vacuum with exhaust tube at outlet

Gas inlet temperatures

Operating condition	Inlet pressure	Permitted range of gas temperatures at inlet
Continuous operation	> 75 Torr (100 mbar) (high gas load)	➔ 50 °F to 104 °F (+10°C to +40°C)
Continuous operation	< 75 Torr (100 mbar) (low gas load)	➔ 32 °F to 140 °F* (0°C to +60°C*)
Short-time (< 5 minutes)	< 75 Torr (100 mbar) (low gas load)	➔ 14 °F to 176 °F* (-10°C to +80°C*)

* if pumping potentially explosive atmospheres: 50 °F to 104 °F (+10°C to +40°C)

We reserve the right for technical modification without prior notice!

Wetted parts

Components	Wetted materials
Pump	
Housing cover insert	PTFE carbon reinforced
Head cover	ETFE
Diaphragm clamping disc	ETFE carbon fiber reinforced
Diaphragm	PTFE
Valves	FFKM
Inlet / outlet	ETFE
Fittings	ETFE
Tubing	PTFE
Pumping unit	
Inlet pumping unit	PP
Outlet pumping unit	PET
Distribution head (inlet)	PPS glass fiber reinforced
Tubing	PTFE
Fittings	ETFE
O-ring at catchpot	Fluoroelastomer
Blind plug (inlet)	PP
Overpressure safety relief device	PTFE / silicone rubber
Exhaust waste vapor condenser / catchpot	Borosilicate glass

We reserve the right for technical modification without prior notice!

Abbreviations

- AK:** Separator for condensates, catchpot at inlet or outlet
EK: Exhaust vapor condenser
ETFE: Ethylene/Tetrafluoroethylene
FFKM: Perfluoro elastomer
GND: Ground
PET: Polyethylene terephthalate
PP: Polypropylene
PPS: Polyphenylene sulfide
PTFE: Polytetrafluoroethylene
PWM: Pulse width modulation

Pump parts

Position	Component
1	Chemistry diaphragm pump MD 1C
2	Power connection
3	ON/OFF switch
4	Voltage selection switch
5	Fuse holder
6	Pump rating plate
7	Inlet
8	Outlet
9	Fan
10	Gas ballast valve

Position	Component
11	Recessed grip / handle
12	Control line
13	Exhaust waste vapor condenser
14	Catchpot
15	Coolant inlet
16	Coolant outlet
17	Overpressure safety relief device
18	Distribution head
19	Blind plug

MD 1C

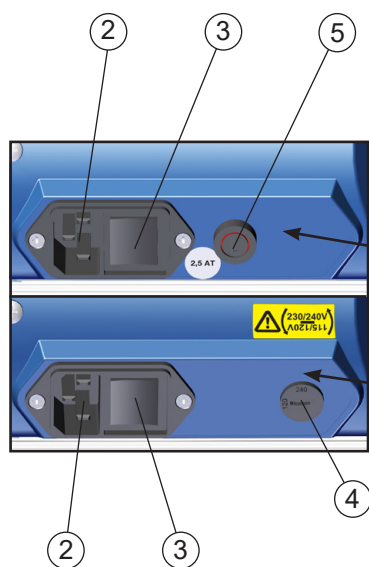
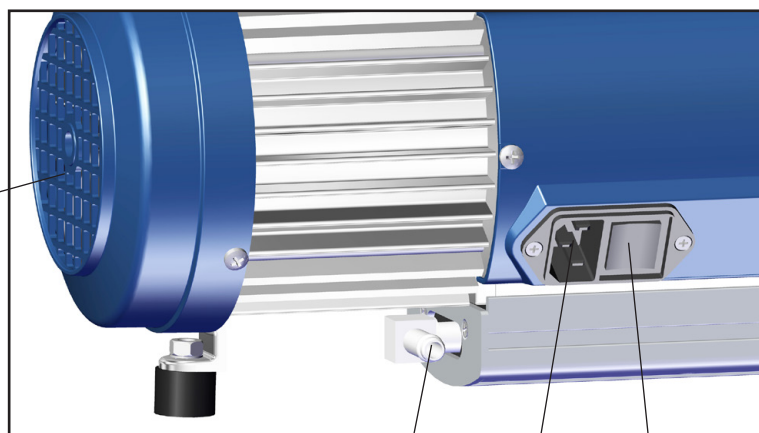
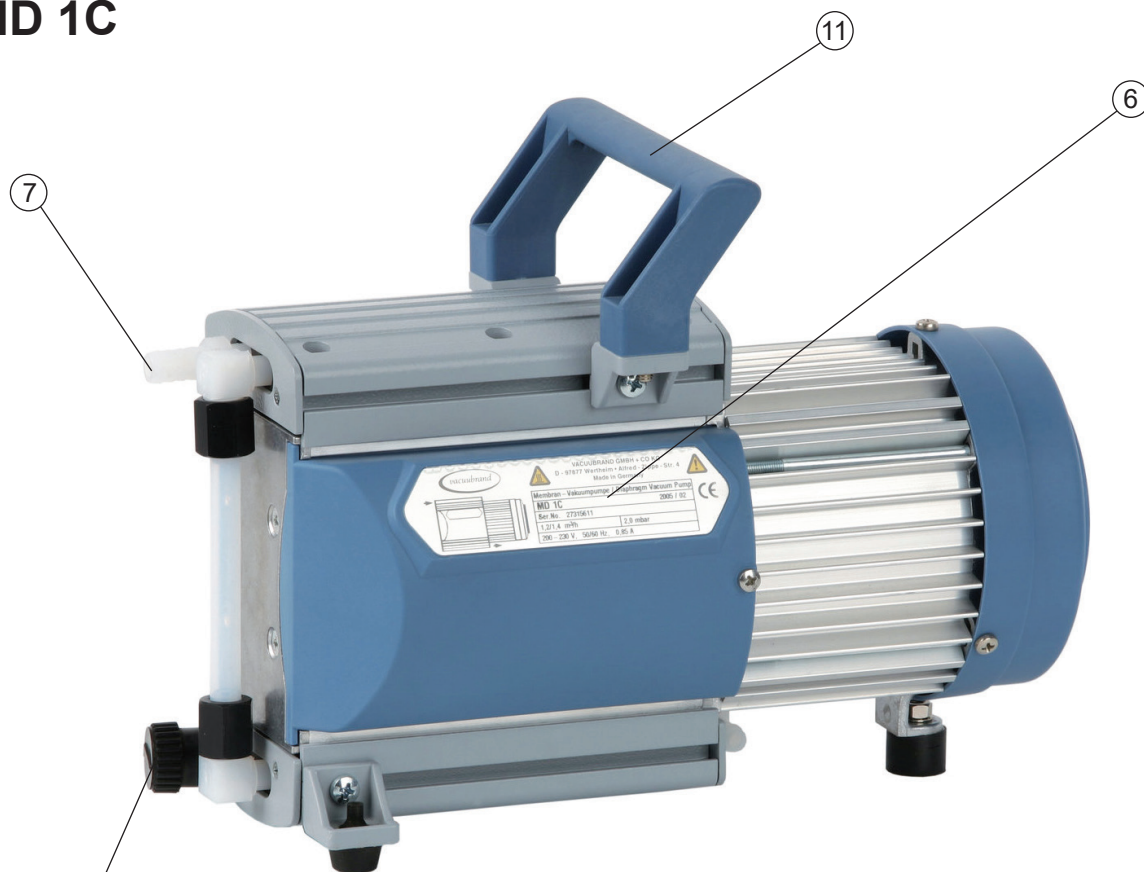

MD 1C C/US

only pump with dual-voltage motor

MD 1C + AK + EK

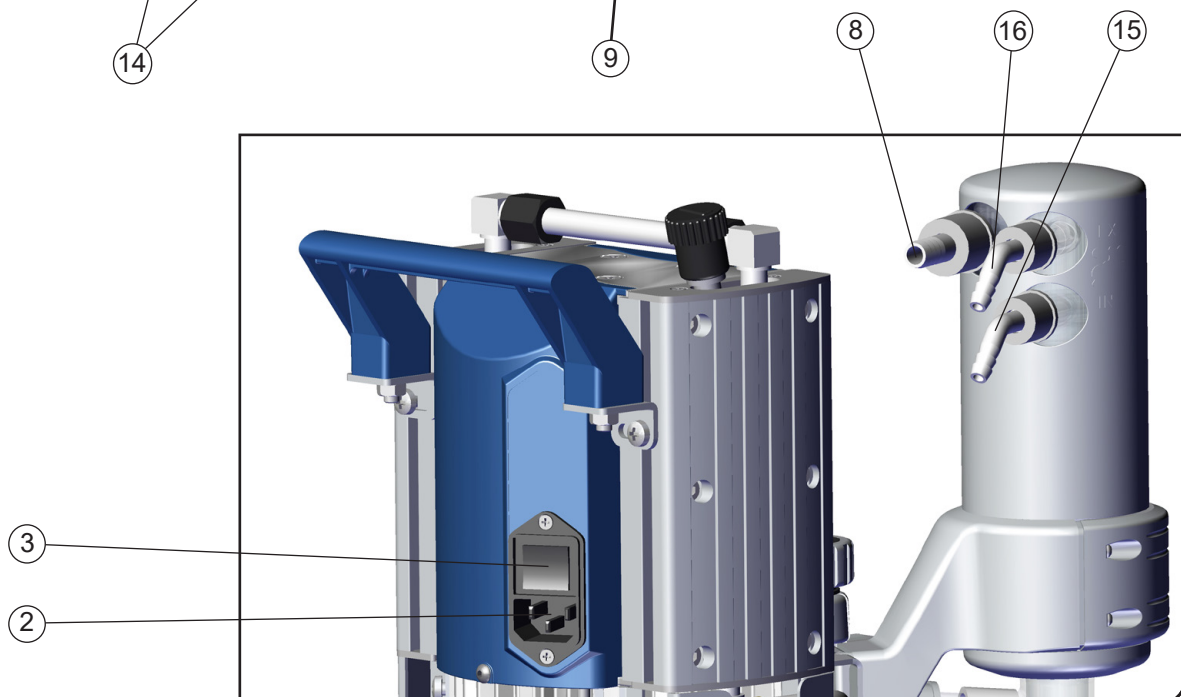
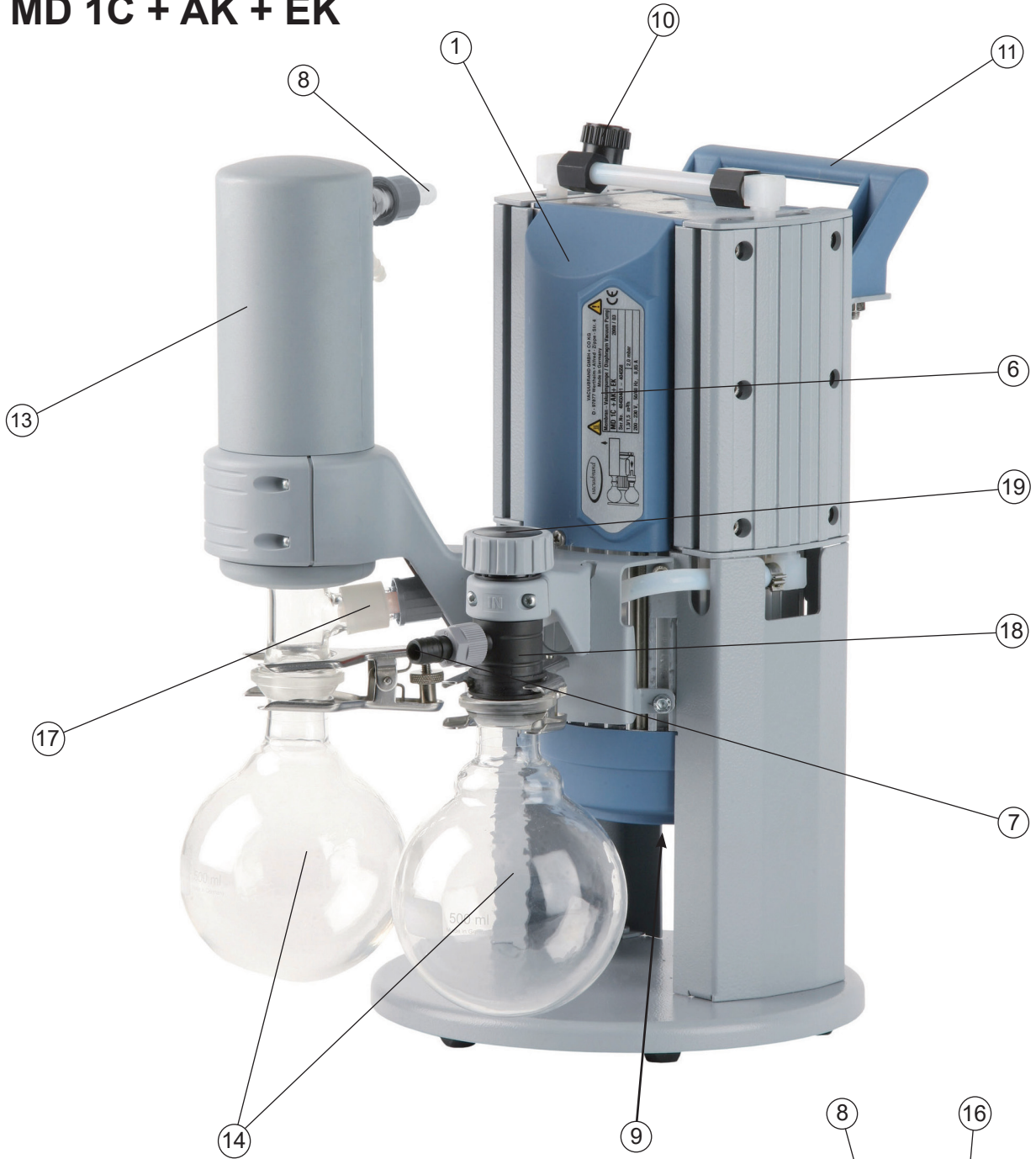

MD 1C VARIO-SP

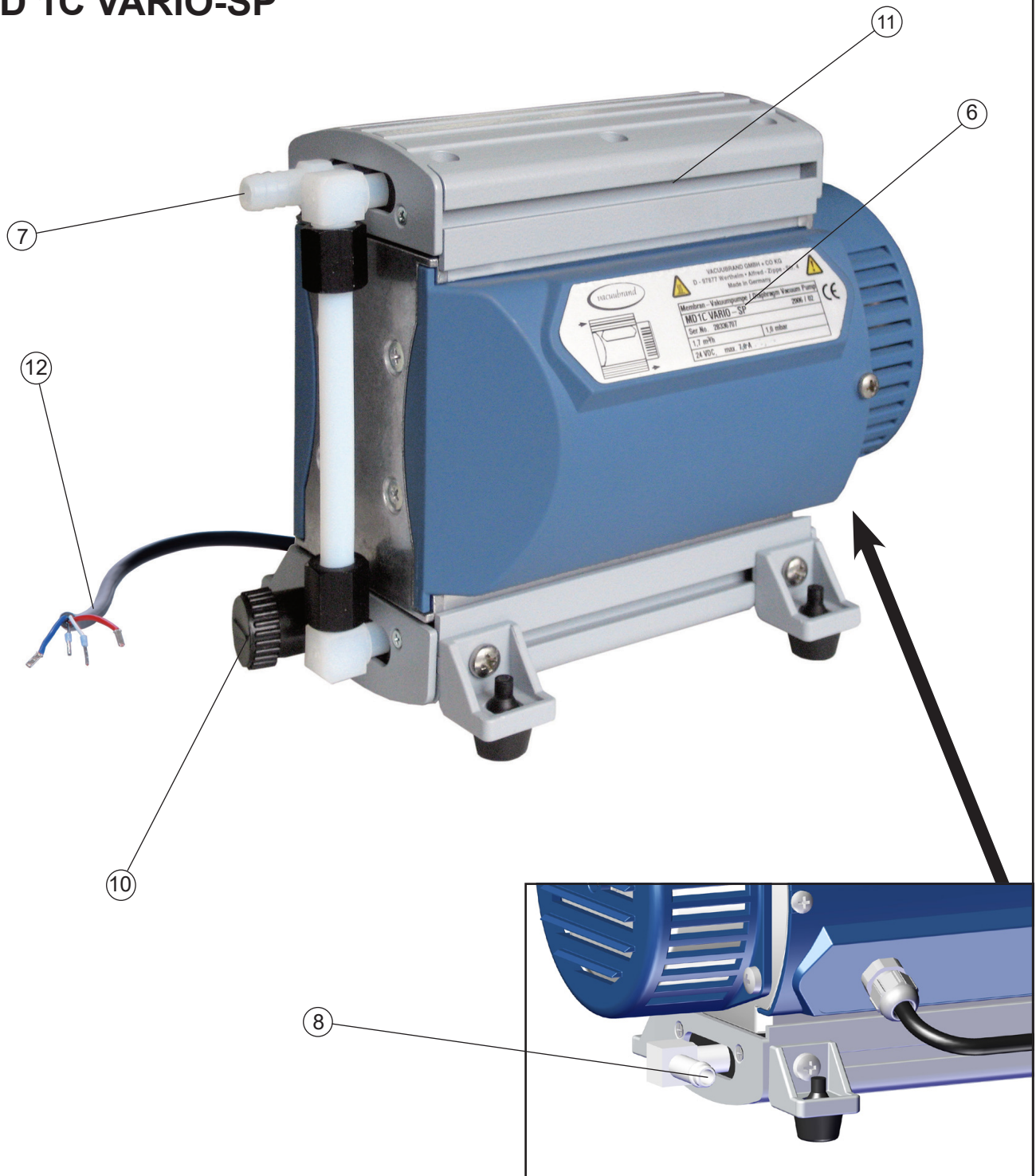

Ensure sufficient venting of the pump!

Only pumps with dual-voltage motor:

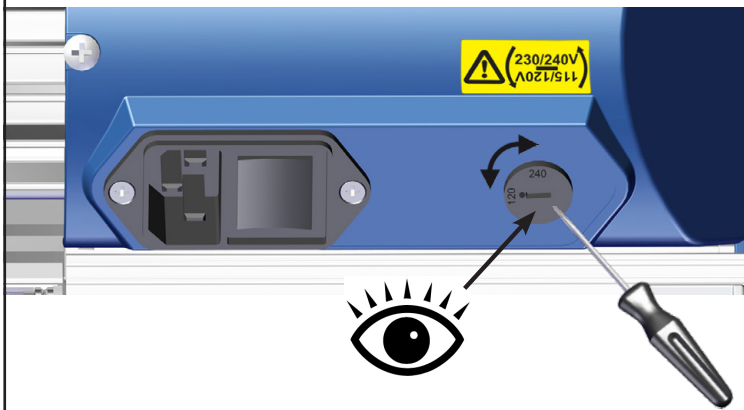

Voltage selection switch:

1. Disconnect the electrical power cord.
2. Use a screw driver to adjust the **voltage selection switch** to the supply voltage:

"115/120" corresponds to 100-120 V and
 "230/240" corresponds to 200-230 V.

CAUTION

- Check that the voltage selection switch is positioned correctly. Check every time before starting the pump.
Note: If the pump is switched on with wrong voltage selection, the motor may be damaged!
- **Change the selection at the voltage selection switch only if the pump is unplugged from the power source.**

Replacing the device fuse (only MD 1C C/US)

⚠ DANGER

➔ **Switch off the pump.**



➔ **Disconnect the electrical power cord** before unscrewing the fuse holder.

Identify and eliminate the cause of failure before switching on the pump again.

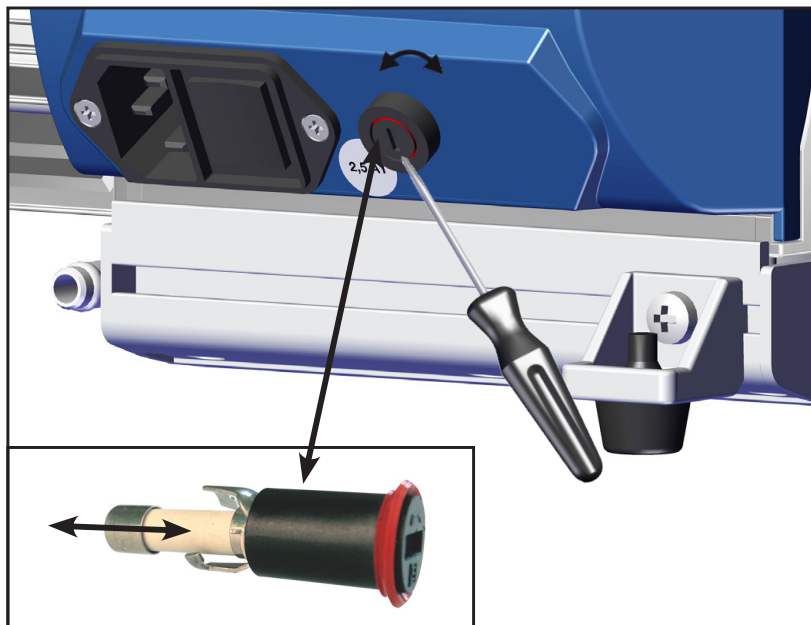

➔ Unscrew the fuse holder at the side of the pump using a slotted screw driver.

➔ Replace the defective fuse by a fuse of the same type (250 V / 2,5 AT – 5x20). Reassemble holder with fuse to the pump.

➔ Order number fuse 250 V / 2,5 AT – 5x20 (10 pieces): 20612408

Replacing the fuse on the circuit board (only MD 1C VARIO-SP)

⚠ DANGER

- ➔ Separate the pump from mains.
- ➔ Wait until live parts are discharged.
- ➔ Identify and eliminate the cause of failure prior to re-start.

NOTICE



Attention: Electrostatic sensitive device!

All work related to the circuit board must be carried out in a ESD protected area or under ESD protective measures!

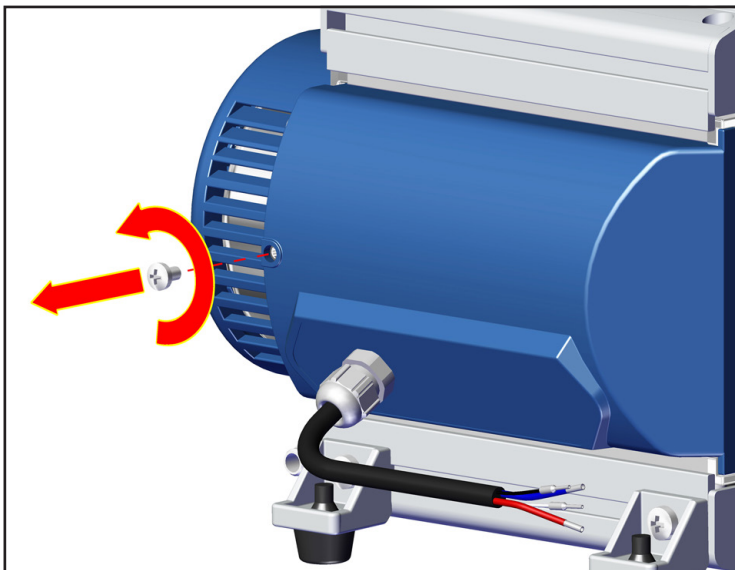

Unscrew screw at the cover.

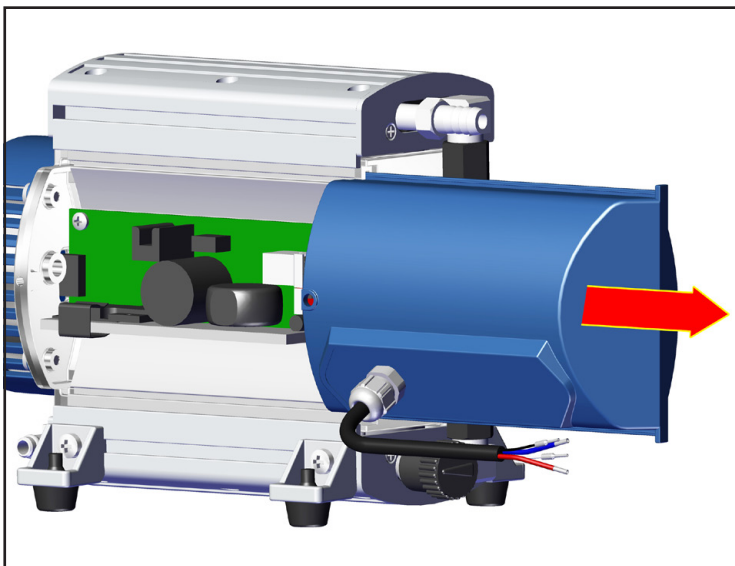

Slide the cover aside carefully and only as far as necessary.

Remove the defective fuse with a tweezer and replace by a new one of the same type.

➡ Order number fuse 125 V / F 7 A – 2x7: 20612524 (10 pieces)

Layout circuit board

Fuse 125 V / F 7 A – 2x7 mm

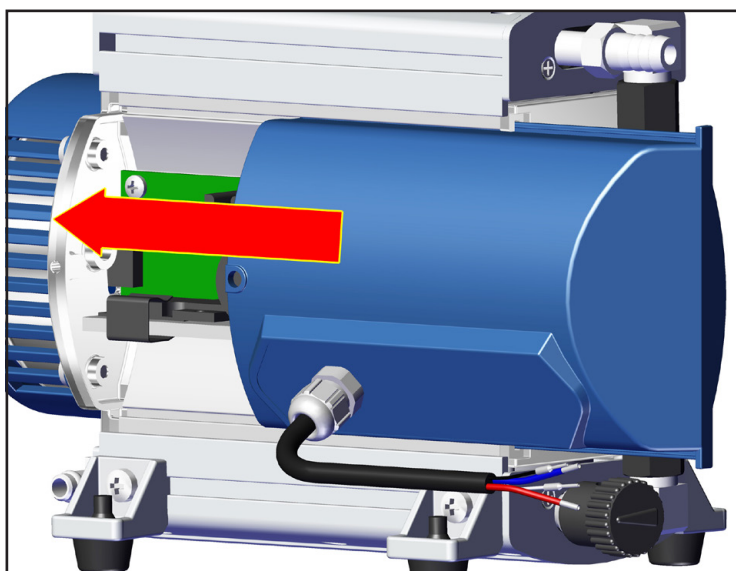
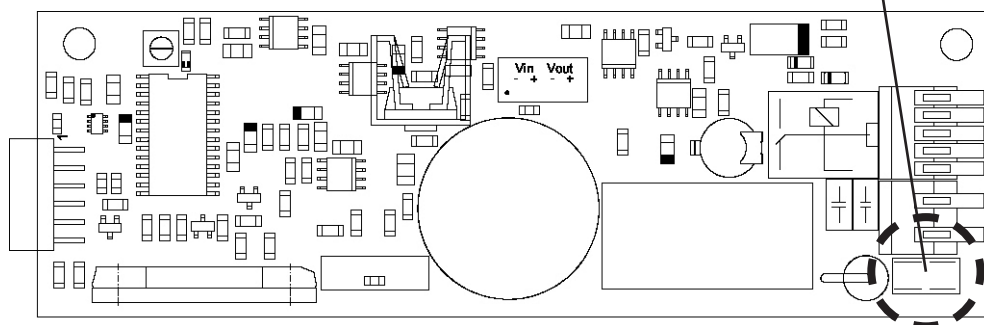

Assemble cover after replacing the fuse.

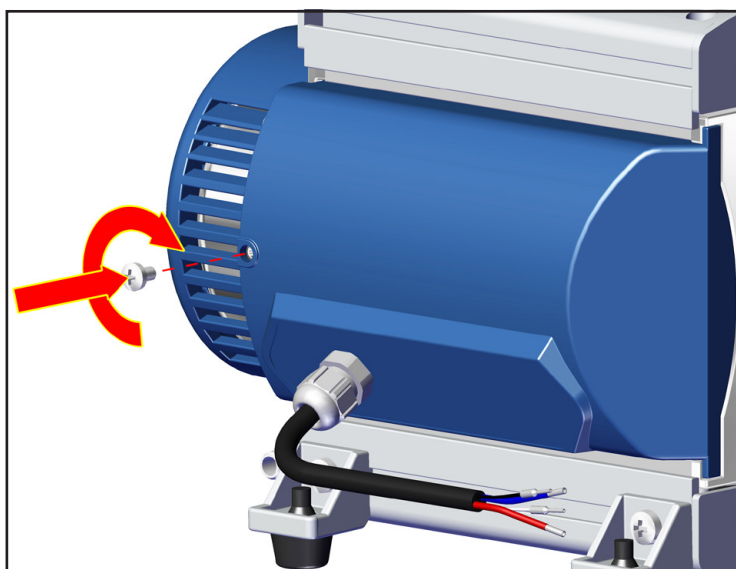

Screw cover.

Use and operation

Installation

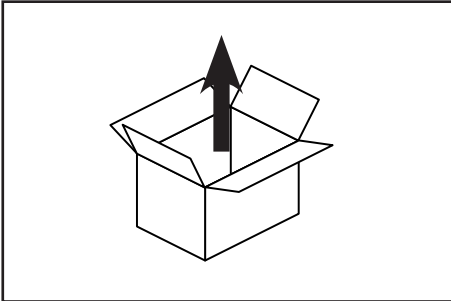

Remove the product from its packing-box.

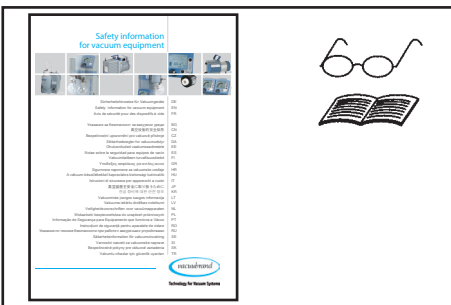

Read the document "Safety information for vacuum equipment" and observe the instructions contained therein!

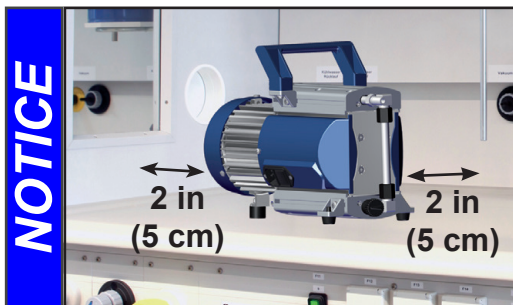

Put the pump in place.

Keep a minimum distance of 2 in (5 cm) between the cooling fan and surrounding items (e.g., housing, walls, etc.), or else install an external automatic ventilation system.

WARNING

☞ Make sure ventilation is adequate, especially if the pump is installed in an enclosure, or if the ambient temperature is elevated. Provide external ventilation, if necessary.

NOTICE

The mains plug is a disconnecting device to separate the pump from the supply voltage. Ensure that the mains plug is easily accessible at all times to allow the separation of the device from the power supply.

Vacuum connection (inlet)

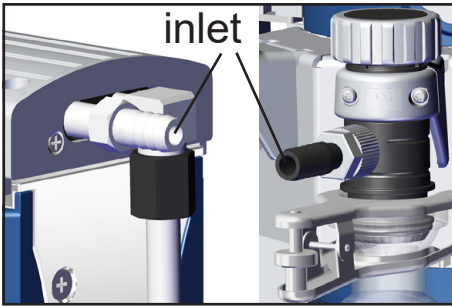

Inlet: Hose nozzle for tubing I.D. 3/8" (hose nozzle DN 10 mm).

Connect the vacuum line (e.g., vacuum hose DN 10 mm) at the inlet of the pump.

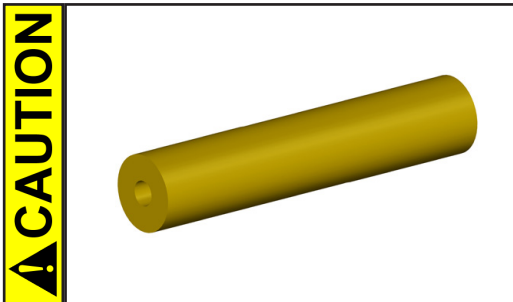

- Reduce the transmission of vibration. Prevent mechanical load due to rigid pipelines. Insert elastic hoses or flexible elements as couplings between the pump and rigid pipes.

Note: Flexible elements will compress or flatten when evacuated if not designed for use under vacuum.

- Hose connections at the pump inlet must always be gas tight.

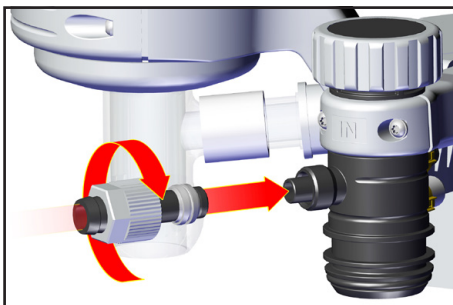

MD 1C + AK + EK:

Assembling the hose nozzle with union nut:

- Take the hose nozzle with attached compression ferrule and union nut out of the catchpot and put onto inlet connection.
- Tighten the union nut by hand until you can feel the stop. Then tighten an additional 1/4 rotation with an open-ended wrench (size 17mm) for final installation.

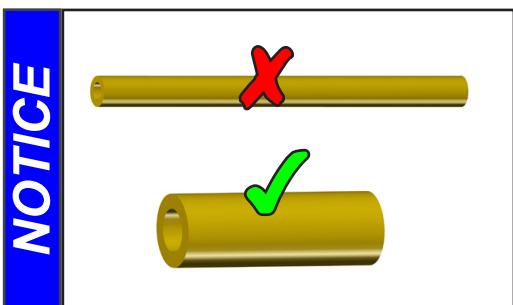

Use connecting hoses with large diameter and keep them as short as possible to avoid flow losses. Locate the pump as closely as possible to the application.

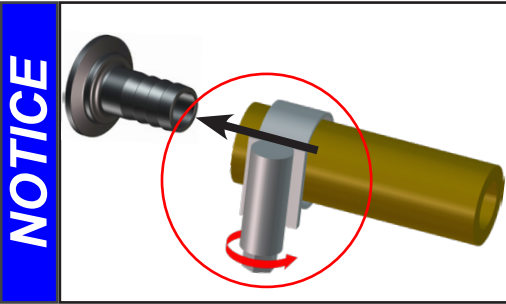

Secure hose connections at the pump appropriately, e.g., with hose clamps, to protect against accidental detachment.

⚠ WARNING

- ☞ Particles and dust must not be aspirated. If necessary, you must install appropriate filters. You must ensure their suitability concerning gas flow, chemical resistance and resistance to clogging prior to use.

⚠ CAUTION

- A power failure may cause accidental ventilation of the pump, especially if the gas ballast valve is open. If this constitutes a potential source of danger, take appropriate safety measures.

NOTICE

When assembling, ensure **vacuum-tightness**. After assembly, check the whole system for leaks. Use a suitable valve (see „Accessories“, pg. 55) to isolate the pump from the vacuum application. This is to allow the pump to warm up before pumping condensable vapors and to clean the pump after use before it is switched off.

Separator (AK) at the inlet

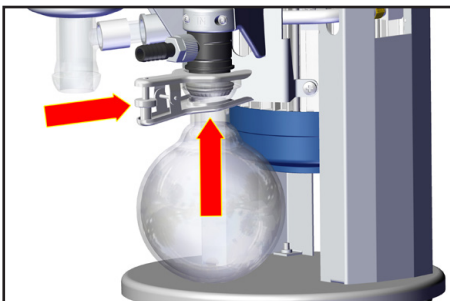

The separator at the inlet protects against droplets and particles from entering the pump.

- ☞ Enhances lifetimes of diaphragms and valves.
- ☞ Improves vacuum performance in applications with condensable vapors.

Catchpot:

The catchpot is coated with a protective layer to protect against shattering in case of breakage or implosion.

- ➡ Assemble the catchpot at the inlet using a joint clip.

Connecting the outlet

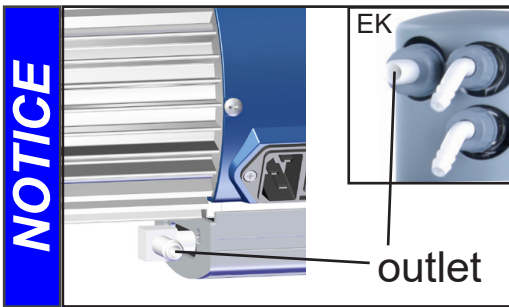

Outlet via hose nozzle for tubing I.D. 5/16" (hose nozzle DN 8 mm) or via hose nozzle for tubing I.D. 3/8" (hose nozzle DN 10 mm) at exhaust waste vapor condenser EK.

⚠ DANGER

➔ If dangerous or polluting fluids could be released at the outlet, install an appropriate system to catch and dispose of those fluids.

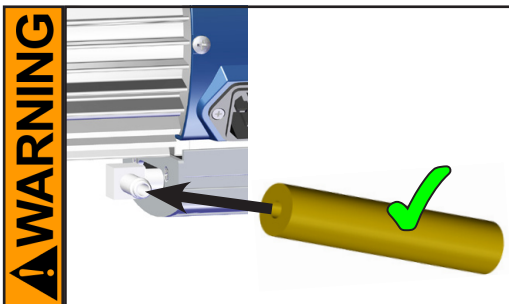

☞ Connect a gas-tight exhaust line at the pump outlet if necessary. Always vent exhaust gases appropriately (e.g., into a fume hood).
☞ Never block the gas outlet. The exhaust line must always be free of obstructions (no back pressure) to ensure an unimpeded discharge of gas. The cross-section of the outlet tubing must be at least the size of the pump's exhaust connection.

⚠ CAUTION

• Reduce the transmission of vibration. Prevent mechanical load due to rigid pipelines. Insert elastic hoses or flexible elements as couplings between the pump and rigid pipes.

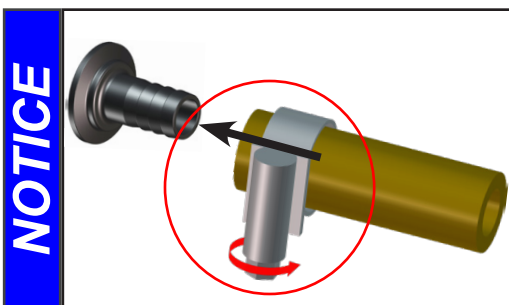

Secure hose connections at the pump appropriately, e.g., with hose clamps, to protect against accidental detachment.

To reduce pump noise emanating from the pump exhaust port, connect an exhaust hose or use a silencer (see „Accessories“, pg. 55).

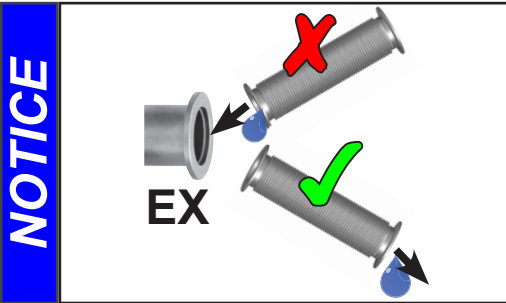

Always install outlet tubing descending from the pump or provide other measures to avoid backflow of condensate towards the pump.

Exhaust waste vapor condenser (EK) at the outlet

The **exhaust waste vapor condenser** enables an efficient condensation of the pumped vapors at the outlet.

- ☞ No backflow of condensates.
- ☞ Controlled recovery of condensates.
- ☞ Close to 100% solvent recovery.
- ☞ The isolation cover protects against glass splinters in case of breakage, acts as thermal isolation to avoid condensation of humidity and is intended to absorb shocks.

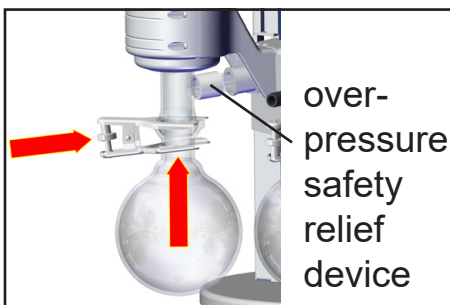

Catchpot:

The catchpot is coated with a protective layer to protect against shattering in case of breakage or implosion.

- ➔ Assemble the catchpot at the exhaust waste vapor condenser using a joint clip.

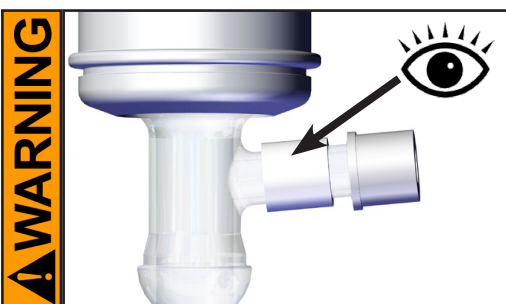

- ☞ Check the overpressure safety relief device at the exhaust waste vapor condenser regularly; replace if necessary. Check especially for deterioration, coalescence and cracks.

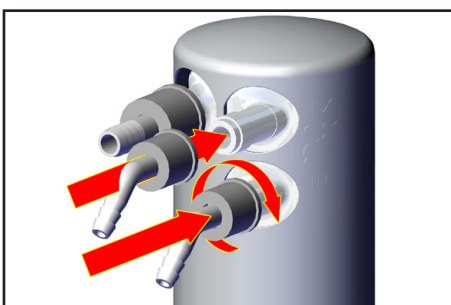

- ➔ Assemble the hose nozzles for coolant inlet and coolant outlet tubing at the exhaust waste vapor condenser (hose nozzles for tubing I.D. 1/4"-5/16" (6-8 mm)).
- ➔ Attach the tubing of the coolant circuit to the respective hose nozzles at the waste vapor condenser.

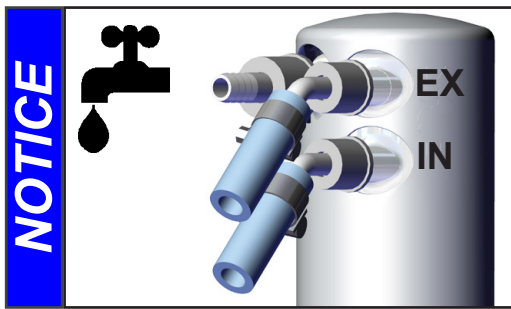

Check all hose connections prior to starting operation of the cooling system. Secure coolant hoses at the hose nozzles (e.g., with hose clamps) to prevent their accidentally slipping off.



➔ Prevent the discharge of dangerous gases and vapors to the surrounding atmosphere. If appropriate, connect the exhaust line to a suitable treatment system.

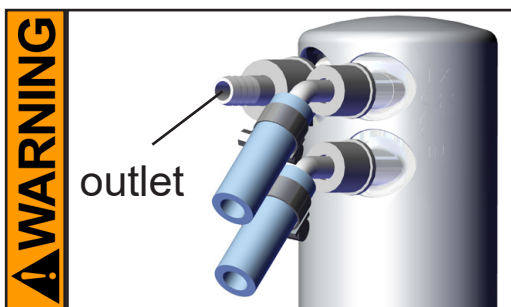

☞ Never block the gas outlet (hose nozzle for tubing I.D. 3/8" (10 mm)). The exhaust hose has always to be unobstructed and without back pressure to enable an unhindered discharge of gases and protect the pump valves from damage.

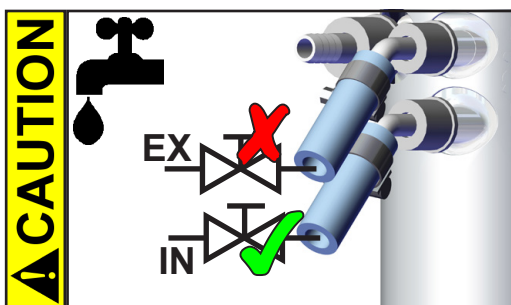

- Only install the optional coolant valve in the supply line of the exhaust waste vapor condenser.
- **Note:** Install the hoses of the cooling system in a way to avoid the flow / dripping of condensed water onto the pumping unit (especially cables and electronic parts, see also IP degree of protection, „Technical data“, pg. 25).

- Ensure that the **coolant outlet tubing** is always unobstructed and that it cannot get blocked.
- Maximum permissible coolant pressure at the exhaust waste vapor condenser: 87 psi (6 bar) absolute. Outlet flow must always be unhindered.
- Comply with the maximum permissible coolant pressures of additional components in the coolant circuit (e.g., coolant valve).
- Avoid overpressure in the coolant circuit (e.g., caused by blocked or squeezed coolant hoses).

NOTICE

Permissible range of coolant temperature at the exhaust waste vapor condenser: 5°F to 68°F (-15°C to +20°C)

Check hose connections prior to starting operation of the cooling system.

Check coolant hoses regularly during operation.

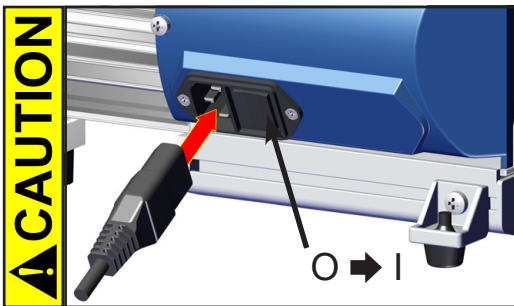
Electrical connection**MD 1C (AC motor)**

Plug in the power cord.

- Check the power source and the pump's rating plate to be sure that the power source and the equipment match in voltage, phase, and frequency.

Switch the pump on.

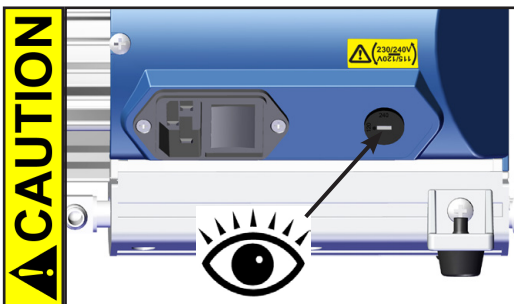
**Pump with dual-voltage motor:**

- Check the power source and the pump's rating plate to be sure that the power source and the equipment match in voltage, phase, and frequency.
- Check that the voltage selection switch is positioned correctly. Check every time before starting the pump. **Note:** If the pump is switched on with wrong voltage selection, the motor may be damaged!

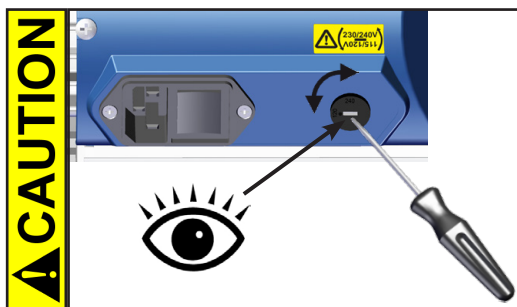

Changing the selection at the voltage selection switch:

- Change the selection at the voltage selection switch only, if the pump is unplugged from the power source.

1. Disconnect the electrical power cord.
2. Use a screw driver to adjust the voltage selection switch to the supply voltage:

"115/120" corresponds to 100-120 V and
 "230/240" corresponds to 200-230 V.

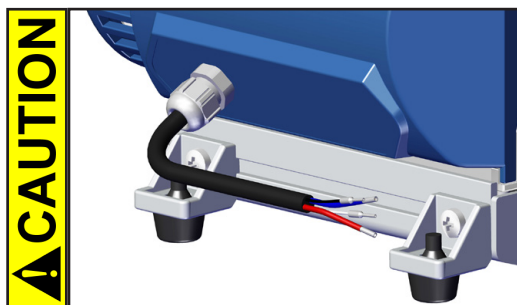

MD 1C VARIO-SP (DC motor)

- Check the power source and the pump's rating plate to be sure that the power source and the equipment match in voltage, phase, and frequency.

Connect the supply voltage and the control signal to the pump's control line (see „Controlling the MD 1C VARIO-SP“, pg. 45).

Switch the supply voltage and, if required, the control signal on.

Controlling the MD 1C VARIO-SP

Connecting the cable:

The connecting cable contains four differently colored wires.

wire in control line	assignment
red ●	+24V DC (supply voltage, max 7A)
blue ●	GND (24V)
white ○	PWM: 5V to max. 24V or voltage input: 0V to 10V DC (max. 24V) (depending on the control signal input for motor speed)
black ●	GND Signal

External setting of the motor speed via PWM (*factory set*):

PWM (pulse-width modulation; Low: 0V - 0.5V; High: 5V - 24V max.)

frame frequency: 100Hz to 1.5kHz

0% to 100% PWM: Linear increase of the motor speed:

0 rpm (at 0% PWM) to 2400 rpm (at 100% PWM)

Pump will run smoothly only at motor speeds higher than 200 rpm.

Example: Pulse-width at a frame frequency of 1 kHz
and at 700 rpm motor speed: 0.3 ms

NOTICE

As set at the factory, the pump is designed for operation with a control signal; i.e., without a control signal, the pump does not start!

To operate the pump without a control signal, change the settings on the circuit board (see below)!

Selecting the control signal input: (PWM / voltage / internal setting)

To select a control signal input other than the factory set one (PWM), the control line at the terminal board has to be reconnected.

NOTICE



Attention: Electrostatic sensitive device!
All work related to the circuit board must be carried out in a ESD protected area or under ESD protective measures!

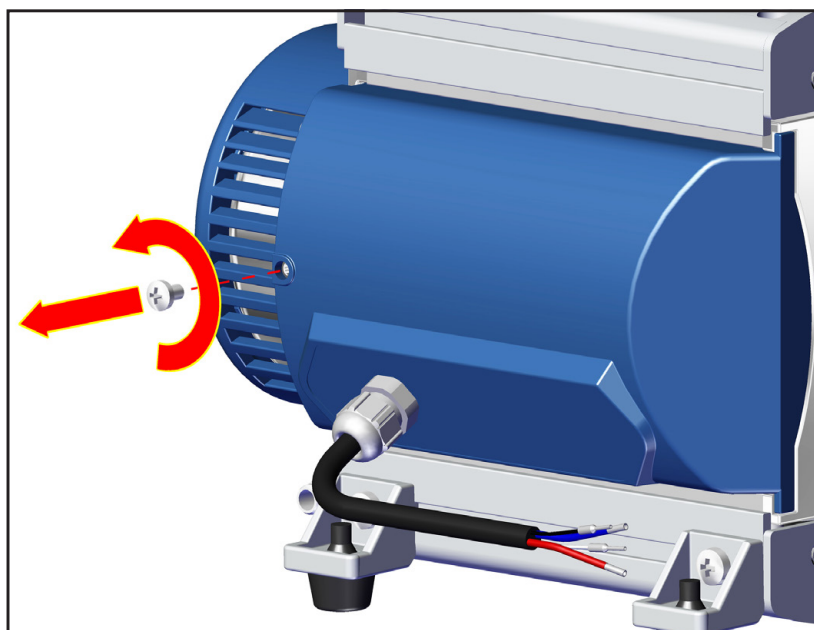

⊕ size 2
1x

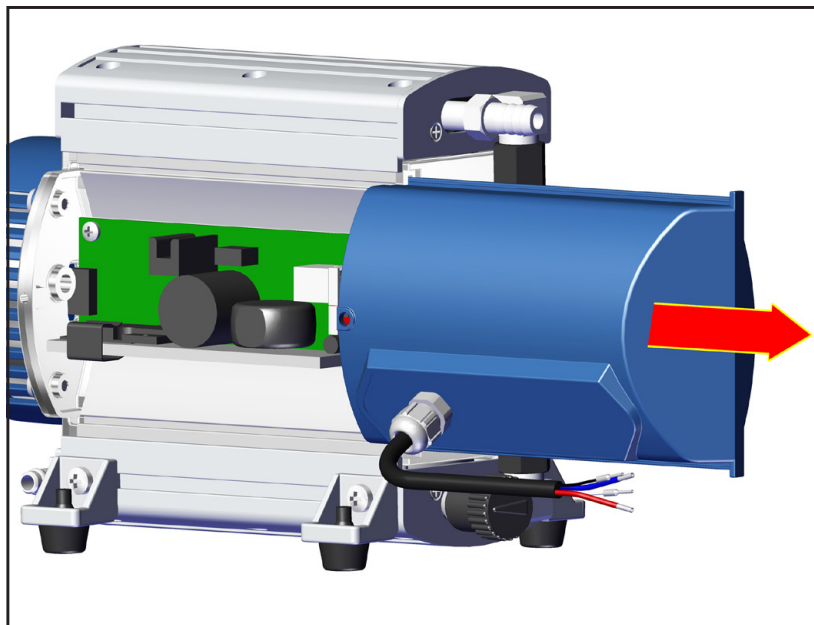

Slide the cover aside carefully and only as far as necessary.

Layout of circuit board

trimming potentiometer

terminal board (ST1A / ST1B),
connection of control line
(supply voltage and control signal;
see print on the circuit board)

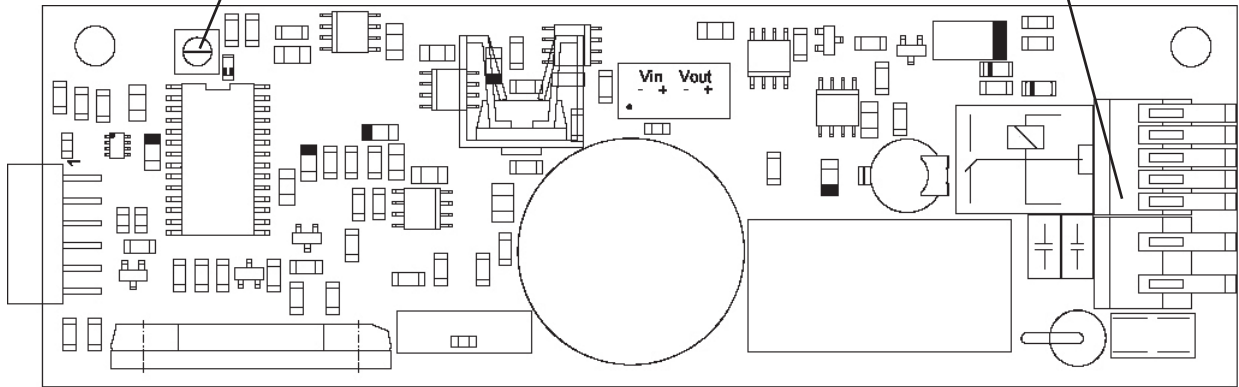

Terminal board

(Connection of the control line on the circuit board)

Voltage supply:

Terminal ST1A	+UB	GND ⊥
Supply voltage	red ●	blue ●

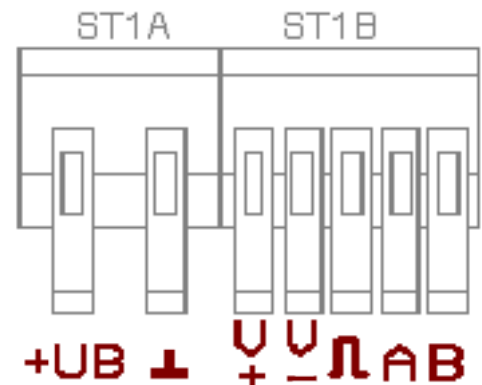

Control signal (setting the motor speed):

Terminal ST1B	V+	V-	PWM Π	A	B
PWM	-	black ●	white ○	-	-
Voltage 0-10V DC	white ○	black ●	-	-	-
Internal setting of the motor speed	-	-	-	-	-

External setting of the motor speed via voltage input:

Voltage input: analog 0V ... 10V DC (max. 24V !)

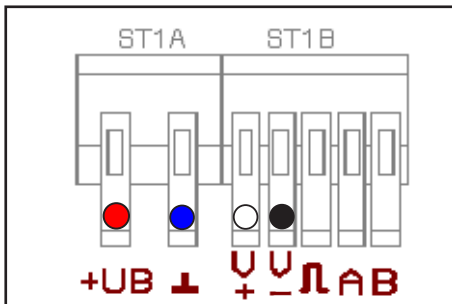

- ➡ Connect the black and the white wire accordingly to the terminal board ST1B (see table above).

0V to 10V:

Linear increase of the motor speed (0 rpm (at 0V) to 2400 rpm (at 10V))

Pump will run smoothly only at motor speeds higher than 200 rpm.

Internal setting of the motor speed via trimming potentiometer:

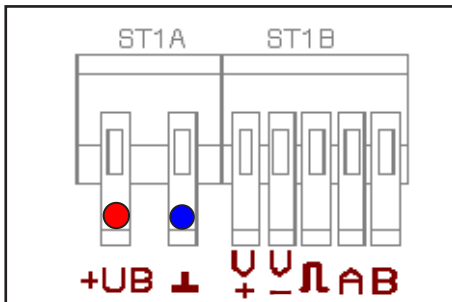

- ☞ Ensure that no control signal is applied, e.g., by removing the white and the black wires from the terminal board ST1B.
- ☞ Supply the pump with the required supply voltage of 24V DC.

Adjusting the motor speed with the trimming potentiometer:

Turning the trimming potentiometer to the right increases the motor speed (maximum 2400 rpm);

Turning the trimming potentiometer to the left decreases the motor speed (minimum 0 rpm). Pump will run smoothly only at motor speeds higher than 200 rpm.

- ☞ To stop pump, disconnect pump from DC voltage supply.

Notes regarding the motor speed

Pumping at **high motor speed** increases the **pumping speed** of the pump. Ensure sufficient cooling of the pump!

Pumping at **low motor speed** increases the lifetime of diaphragms and valves!

The pump attains the best ultimate vacuum in the low speed range between approx. 600 and 1000 rpm.

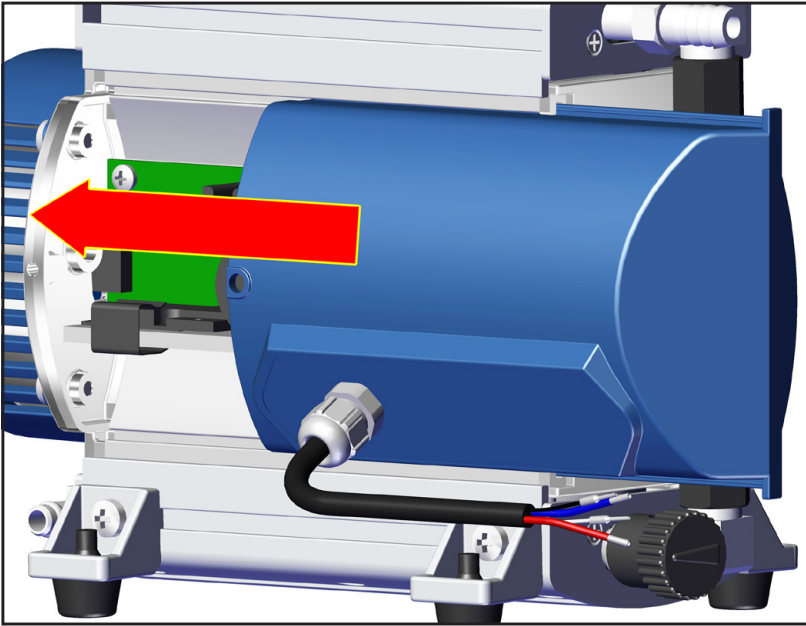

Reassemble the cover after having completed the changes.

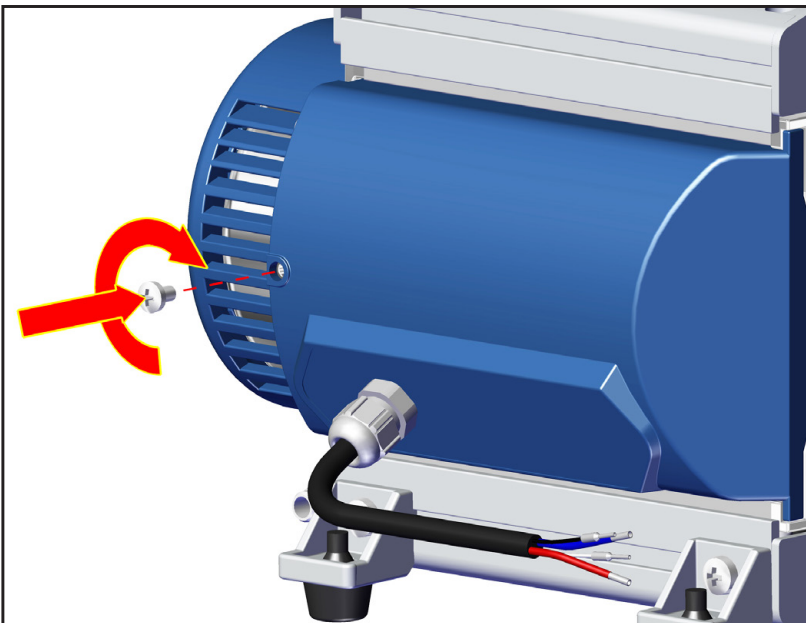

⊕ size 2
1x

During operation

! DANGER

- ➔ Vent and dispose of **potentially dangerous gases or vapors** at the outlet of the pump appropriately.

! WARNING

- ☞ Due to the high compression ratio, the pump might generate overpressure at the outlet. Check pressure compatibility with system components (e.g., exhaust tubing or exhaust valve) at the outlet. Ensure that the pump outlet is neither blocked nor restricted.

- ☞ Operation with silencer (see „Accessories“, pg. 55) at the outlet: Operating the pump at a high inlet pressure or pumping dusty gases for a long time may cause clogging of the silencer. Check the silencer regularly and replace if necessary, or install a hose nozzle instead.

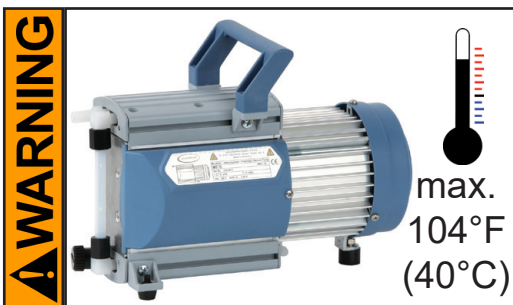

- ☞ **Maximum ambient temperature:** 104 °F (40 °C)
Check the maximum temperatures, if installing the pump in a cabinet or a housing. Make sure ventilation is adequate, especially if the ambient temperature is elevated.

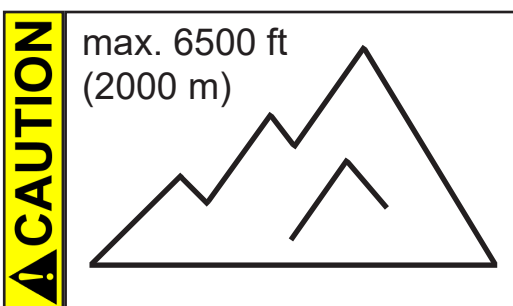

- If the pump is installed at an altitude of more than 6500 ft (2000 m) above mean sea level, check compatibility with applicable safety requirements, and adopt suitable measures. There is a risk of the motor overheating due to insufficient cooling.

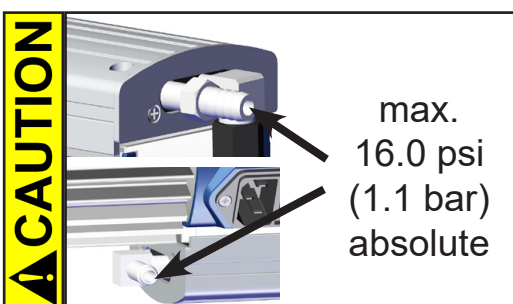

- Check compatibility with the **maximally permitted pressure** at inlet and at outlet and the **maximum pressure difference** between inlet and outlet ports.

NOTICE

Do not start the pump if the **pressure difference between inlet and outlet ports exceeds max. 16.0 psi (1.1 bar)**. Attempts to start the pump at higher pressure difference may cause stalling and damage of the motor.

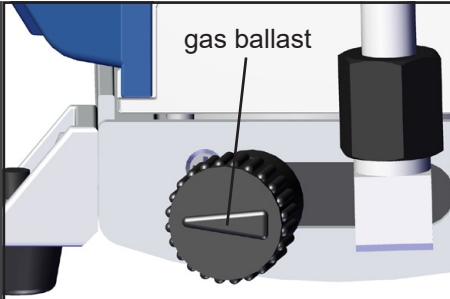
NOTICE

If pumping condensable vapors (water vapor, solvents, etc.), let the pump run with **gas ballast** to help purge any condensation in the pump.

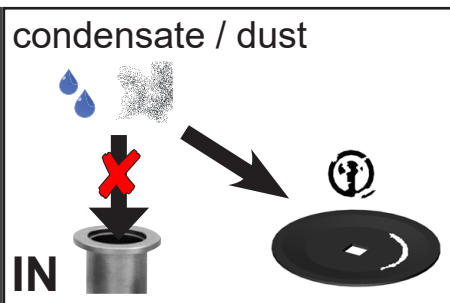
NOTICE

Prevent internal condensation, transfer of liquids or dust. The diaphragms and valves will be damaged, if liquids are pumped in significant amounts.

Check the pump regularly for external soiling and deposits. Clean the pump if necessary to avoid an increase of the pump's operating temperature.

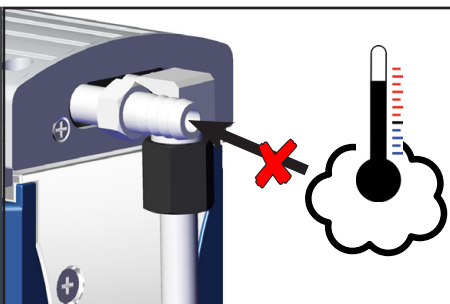
NOTICE

Avoid overheating (e.g., due to hot process gases). Maximum permissible temperature range: see „Gas inlet temperatures“, pg. 27.

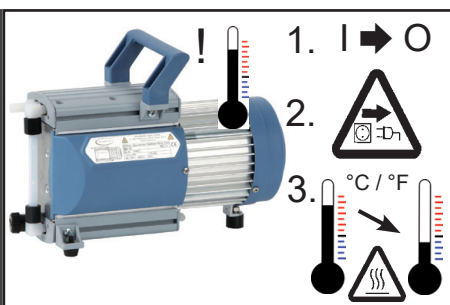
NOTICE**Pumps with AC motor:**

In case of overload, the motor is shut down by a **self-hold thermal cutout** in the winding.

Note: Only manual reset is possible. Switch off the pump and disconnect from the power source. Identify and eliminate the cause of failure. Allow the pump to cool down sufficiently before restart.

NOTICE**Pumps with DC motor:**

A temperature sensor at the circuit board protects the motor of pumps with 24V DC motor. In case of excess temperature, the pump is switched off.

Note: Only manual reset is possible. Disconnect the pump from the power source. Identify and eliminate the cause of failure.

CAUTION

- **Note:** In case of **supply voltage below 115 V**, the lock of the cutout might be impaired and the pump may restart on its own after sufficient cooling down. Take appropriate precautions, if an automatic restart of the pump may lead to a dangerous situation.

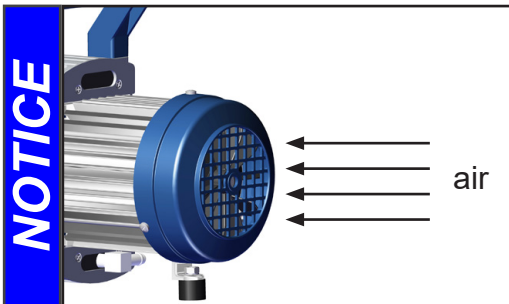

Make sure the fan's air supply is adequate. Check fan regularly for dust/dirt. Clean fan guard grill if necessary to avoid a reduction of ventilation.

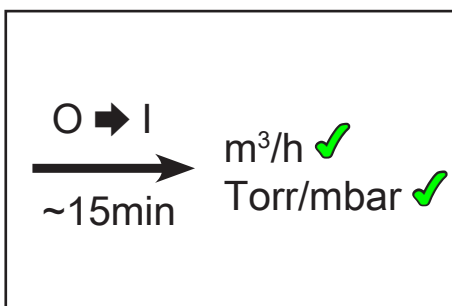

A warm up period (approximately 15 min.) is required to ensure that the rated ultimate vacuum, the pumping speed, and the full vapor pumping rate are attained.

Important notes regarding the use of gas ballast

Gas ballast is a continuous purge to keep the pump's interior as clean as possible and to reduce the possibility of condensation inside the pump.

! DANGER

➔ Air and pumped media might react inside the pump or at the outlet of the pump and form hazardous or explosive mixtures, when you use air rather than inert gas for the gas ballast. This constitutes a risk of significant damage to equipment and/or facilities, a risk of personal injury or even loss of life.

! WARNING

☞ Make sure that air/gas intake through the gas ballast valve can never lead to hazardous, explosive or otherwise dangerous mixtures. If in doubt, use inert gas.

NOTICE

To reduce condensation in the pump, do not pump vapor before the pump has reached its operating temperature. Open the gas ballast valve when pumping condensable vapors. Turn gas ballast cap to open valve.

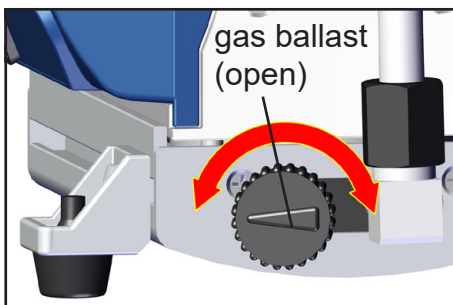

MD 1C / MD 1C VARIO-SP

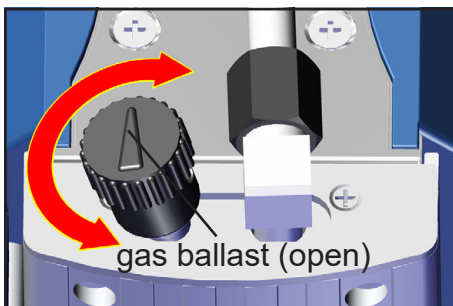

MD 1C + AK + EK

For **condensable vapors** (water vapor, solvents, etc.):

- The gas ballast valve is open if the arrow on the gas ballast cap is pointing away from the pump (**MD 1C / MD 1C VARIO-SP**), respectively towards the pump (**MD 1C + AK + EK**) (see figures).
- With gas ballast valve open, the ultimate vacuum will be reduced.
- Use inert gas for gas ballast to avoid the formation of explosive mixtures. **Attention:** maximum supply pressure of inert gas: 17.5 psi (1.2 bar) absolute.
- Close the gas ballast valve by turning the cap 180°.

In case of low boiling solvents (when the formation of condensate is unlikely), the use of gas ballast might be unnecessary. Operating the pump without gas ballast increases the solvent recovery rate at the exhaust waste vapor condenser (EK).

In case of condensation

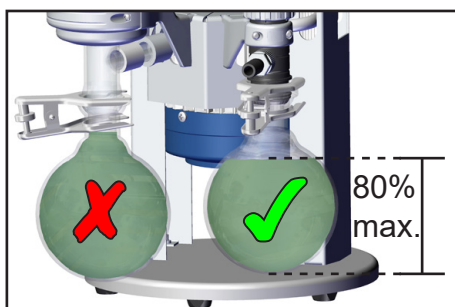

In case of **condensation**: Check the liquid level in the catchpots during operation. Check the liquid level in the catchpots regularly. Do not allow the catchpots to overflow. Drain catchpots in time to avoid overflow. Install a level sensor (see „Accessories“, pg. 55) for monitoring, if necessary (VACUUBRAND controller CVC 3000 or VNC 2 is required).

The maximum liquid level is at approximately 80% of the total filling level to avoid problems when removing the catchpots.

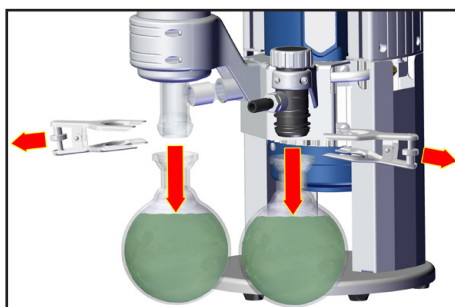

Removing the catchpots:

Catchpot at outlet:

Remove joint clip. Remove catchpot and drain condensate.

Catchpot at inlet:

Admit air or inert gas (via the pump inlet) to restore atmospheric pressure in the catchpot before attempting removal. Remove joint clip. Remove catchpot and drain condensate.



Drain catchpots.

Important: Comply with regulations when disposing of solvents/condensates. Recycle if possible; purify if contaminated.

NOTICE

Reattach drained catchpots.

Shutdown & storage

The pump can be switched off under vacuum.

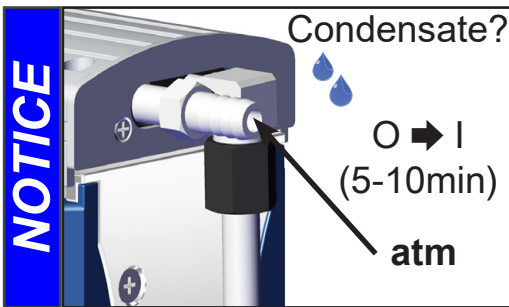

Short-term:

- Has the pump been exposed to condensate?
Allow the pump to continue to run at atmospheric pressure for a few minutes.
- Has the pump been exposed to media which may damage the pump materials or form **deposits**?
Check and clean pump heads if necessary.

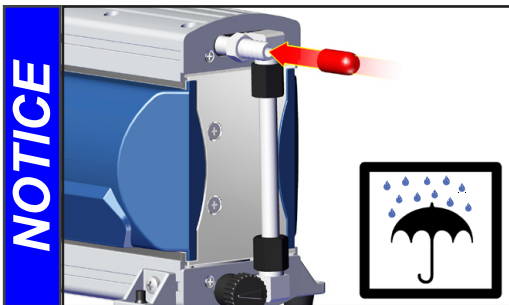

Long-term:

- Take measures as described above regarding short-term shutdown.
- Separate the pump from the application.
- Close inlet and outlet ports (e.g., with transport caps).
- Close the gas ballast valve.
- Drain catchpots.
- Store the pump under dry conditions.

Accessories

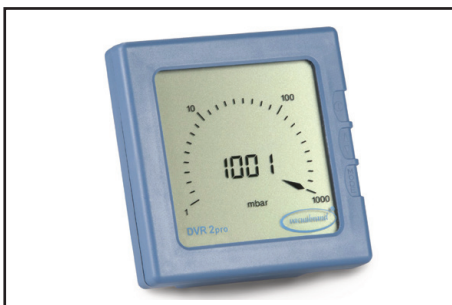

Vacuum gauge DVR 2pro**20682906**

Vacuum hose (caoutchouc) I.D. 3/8" (10 mm ID)**20686002**

Silencer for hose nozzle 3/8" (DN 10 mm)**20636588**

Attention: Dust-laden gases, deposits and condensed solvent vapor can restrict air flow out the silencer. The resultant back pressure can lead to damage of pump bearings, diaphragms, and valves. Under those conditions, a silencer must not be used.



CVC 3000 Vacuum controller.....**20683160**
100-230 V 50-60 Hz

Upgrade possibilities for MD 1C + AK + EK:

In-line valve VV-B 6C, VACUU•BUS, for CVC 3000.....	20674291
Level sensor for catchpots 0.52 qt (500 ml), VACUU•BUS, for CVC 3000	20699908
Solenoid operated valve (C3-B), VACUU•BUS for CVC 3000, for assembly at distribution head	20636668
Upgrade kit SYNCHRO to two inlets (valve block; replaces distribution head)	20699920
Modification kit for small flange KF DN 16..... at inlet of distribution head	20699939
Hose nozzle for tubing I.D. 1/4" / 3/8" (DN 6/10 mm), for inlet at distribution head	20636635
Elbow piece (90°) for PTFE tubing* for assembly at inlet of distribution head	20637873
Blind flange (C1) for assembly at distribution head.....	20677136
Flow control diaphragm valve (C2) for assembly at distribution head	20677137
Manometer module (C5) for assembly at distribution head	20677100
Elbow connecting piece (90°) for PTFE tubing* T-piece for PTFE tubing* PTFE tubing* (sold by meter)	20638434 20638435 20638644

* PTFE tubing DN 10/8 mm

VACUU•LAN® networks are engineered to perform to specification when installed with PTFE tubing, DN 10/8 mm. All VACUU•LAN® modules, pumps and connectors are designed for compatibility with this tubing.

For additional accessories such as vacuum valves, small-flange components, vacuum gauges or vacuum controllers, refer to www.vacuubrand.com

➡ A service manual with exploded view drawings, spare parts list and directions for repair is available on request.

👉 The service manual is intended for trained service people only.

Troubleshooting

Fault	Possible cause	Remedy
<input type="checkbox"/> Pump does not start or stops immediately.	<ul style="list-style-type: none"> ➔ Electrical power cord not plugged in, electrical supply failure? ➔ Device fuse blown (if applicable)? ➔ Overpressure in outlet line? ➔ Motor overloaded? 	<ul style="list-style-type: none"> ✓ Plug in power cord. Check fuse. Check electrical supply voltage. ✓ Identify cause of failure. Replace device fuse. ✓ Remove blockage in line, open valve, or reduce overpressure. ✓ Allow motor to cool down, identify and eliminate cause of failure. Manual reset is necessary. Switch off pump or unplug.
<input type="checkbox"/> Pump does not achieve its ultimate vacuum or usual pumping speed.	<ul style="list-style-type: none"> ➔ Leak in the pipeline or vacuum system? ➔ Long, narrow vacuum line? ➔ Pump has been exposed to condensate? ➔ Deposits have been formed inside the pump? ➔ Diaphragms or valves damaged? ➔ Outgassing substances or vapor generated in the process? ➔ Only VARIO-SP version: Pump temperature too high (motor speed reduced)? 	<ul style="list-style-type: none"> ✓ Check pump directly - connect vacuum gauge directly at pump inlet - then check connection, pipeline and vacuum system if necessary. ✓ Use lines with larger diameter, length as short as possible. ✓ Allow pump to run for some minutes with atmospheric pressure at the inlet to purge. ✓ Clean and inspect the pump heads. ✓ Replace diaphragms and/or valves. ✓ Check process parameters. ✓ Ensure sufficient cooling of the pump or reduce inlet pressure.
<input type="checkbox"/> Pump too noisy.	<ul style="list-style-type: none"> ➔ Atmospheric or high pressure at the pump inlet? ➔ Diaphragm crack or diaphragm clamping disc loose? ➔ Other than above mentioned causes? 	<ul style="list-style-type: none"> ✓ Connect hose or silencer to pump outlet. Be careful not to cause outlet overpressure, especially with condensable vapors. ✓ Perform maintenance. ✓ Contact local distributor.
<input type="checkbox"/> Pump seized.		<ul style="list-style-type: none"> ✓ Contact local distributor.

Replacing diaphragms and valves

☞ Please read section "Replacing diaphragms and valves" completely before starting maintenance.

The pictures may show other versions of pumps. This does not change the method of replacing diaphragms and valves.

DANGER

➔ Never operate the pump if covers or other parts of the pump are disassembled.



➔ Before starting maintenance, **disconnect the electrical power cord (MD 1C with AC motor), respectively the control line (MD 1C VARIO-SP). Wait five seconds** after isolating the equipment from AC power or from supply voltage to allow the capacitors to discharge.

➔ Ensure that the pump cannot be operated accidentally.

➔ **Note:** The pump might be contaminated with the process chemicals that have been pumped during operation. Ensure that the pump is decontaminated before maintenance.

➔ Avoid the release of pollutants.

WARNING

☞ Never operate a defective or damaged pump.

☞ Check every motor capacitor (MD 1C with AC motor) regularly by measuring its capacity and estimating its service life. Replace old capacitors early enough to prevent a failure. The capacitors must be replaced by a trained electrician.



☞ Take adequate precautions to protect people from the effects of dangerous substances that may have contaminated the pump and may be released upon disassembly. Ensure that the maintenance technician is familiar with the safety procedures which relate to the products processed by the pumping system. Use appropriate protective clothing, safety goggles and protective gloves.

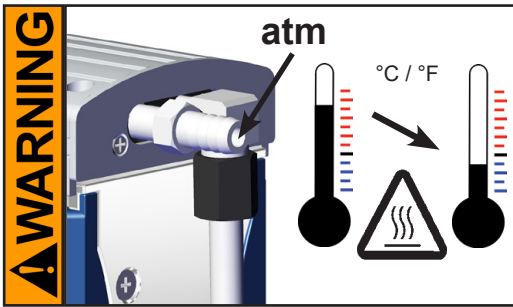

- ☞ Allow sufficient cooling of the pump before starting maintenance.
- ☞ **Vent the pump and isolate it from the vacuum system before you start maintenance.** Drain catchpots, if applicable.

NOTICE

Ensure that maintenance is done only by suitably trained and supervised technicians.

The valves and diaphragms as well as the motor capacitors (MD 1C with AC motor) are wear parts. If the rated ultimate vacuum is no longer achieved or in case of increased noise level, the pump interior, the diaphragms and the valves must be cleaned and the diaphragms and valves must be checked for cracks or other damage.

All bearings are encapsulated and are filled with long-life lubricant. Under normal operating conditions, the drive system is maintenance free.



In demanding circumstances, it may be efficient to check and clean the pump heads on a regular basis. In normal use, the lifetime of the diaphragms and valves is typically 15,000 operating hours.

- Prevent internal condensation, transfer of liquids or dust. The diaphragms and valves will be damaged if liquid is pumped in significant amount.
- Carry out maintenance frequently if the pump is exposed to corrosive media or in case of deposits.
- Regular maintenance will improve the lifetime of the pump and also protect both users and the environment.

Service kit for MD 1C (diaphragms, valves, diaphragm key)**20696828**

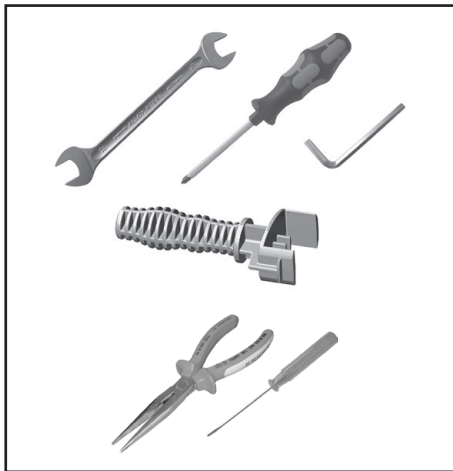
- ☞ Service only one side of the pump at a time to avoid the mixing of parts.
- ☞ In case, support the pump appropriately.



**Tools required (metric):**

- Diaphragm key width 46 mm (included in service kit)
- Open end wrench width 14 / 17 mm 
- 4 mm wide Allen key 

Additionally for MD 1C:

- Phillips screwdriver size 2 

Additionally for MD 1C + AK + EK:

- 2.5 mm wide slotted screwdriver 
- Open end wrench width 10 mm 
- Flat pliers
- 5 mm wide Allen key 

Checking diaphragms and valves

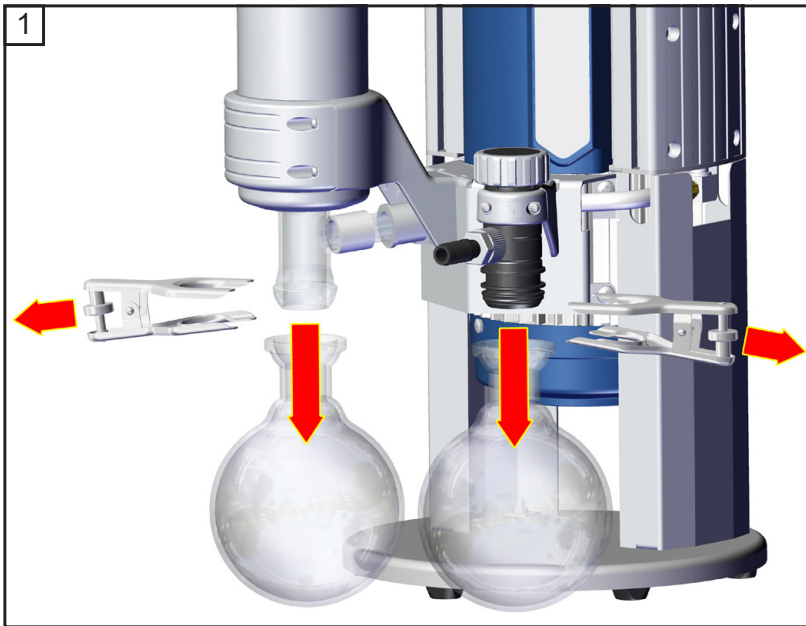

MD 1C + AK + EK

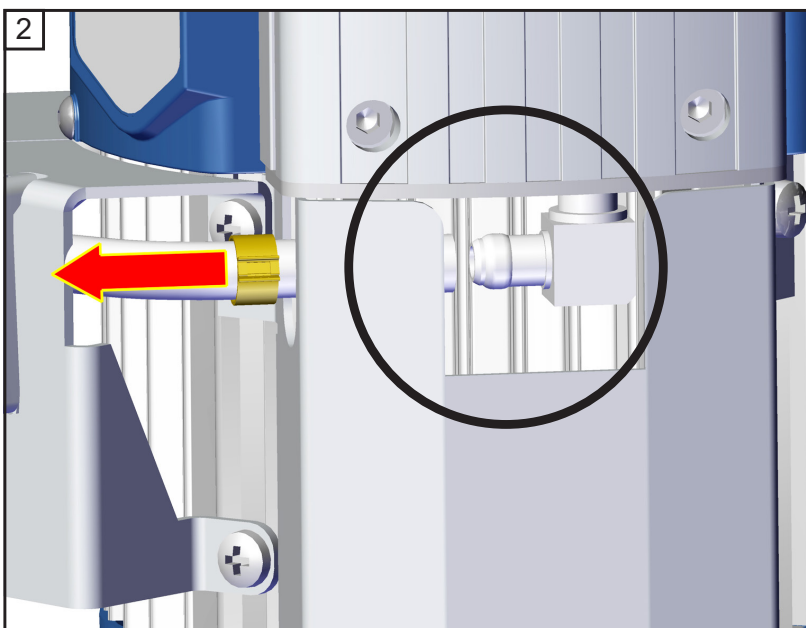

MD 1C + AK + EK

↔ 2.5 mm

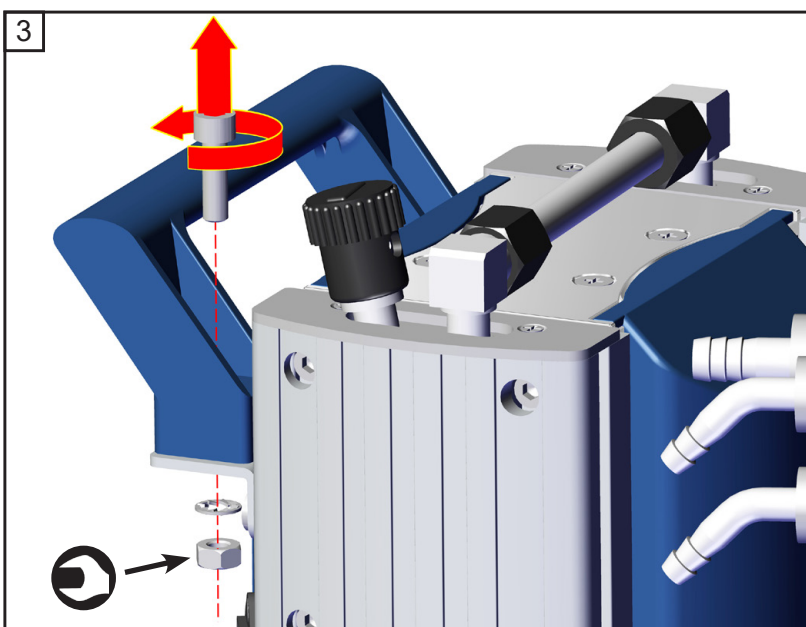

MD 1C + AK + EK

⬡ 5 10 mm
1x

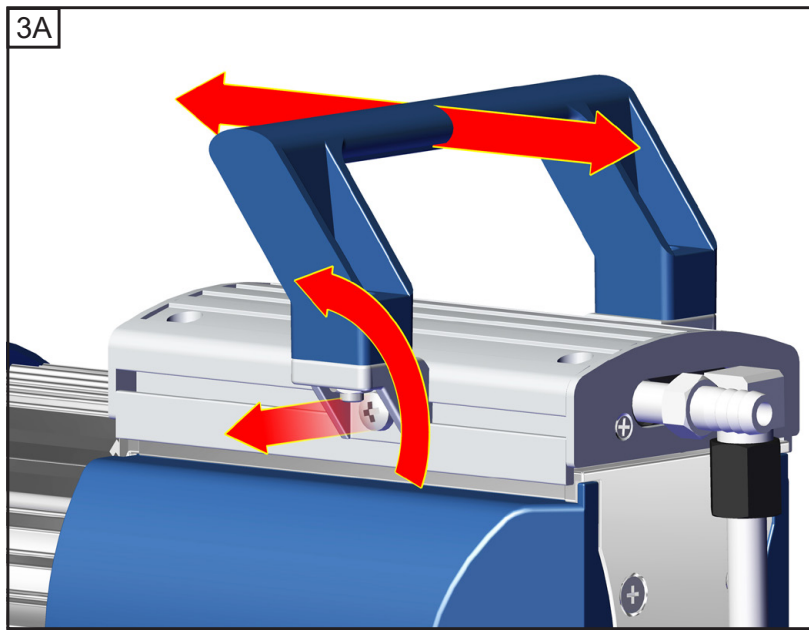

MD 1C

⊕ size 2
2x

1

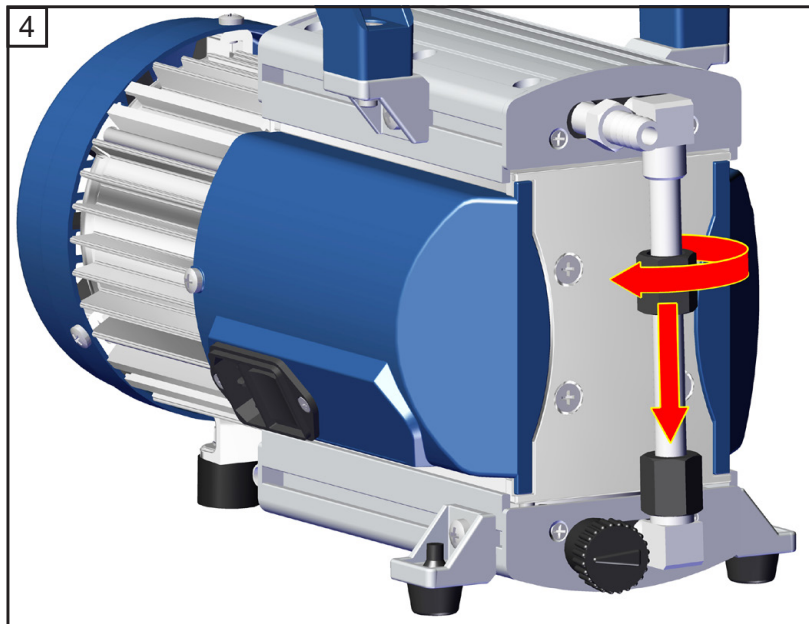

17 mm

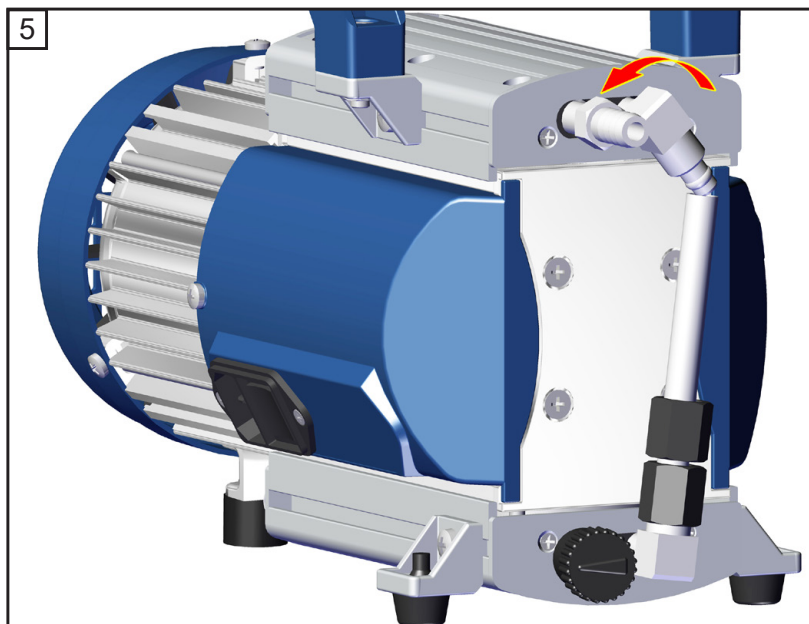

14 mm ↻ max. 1/4

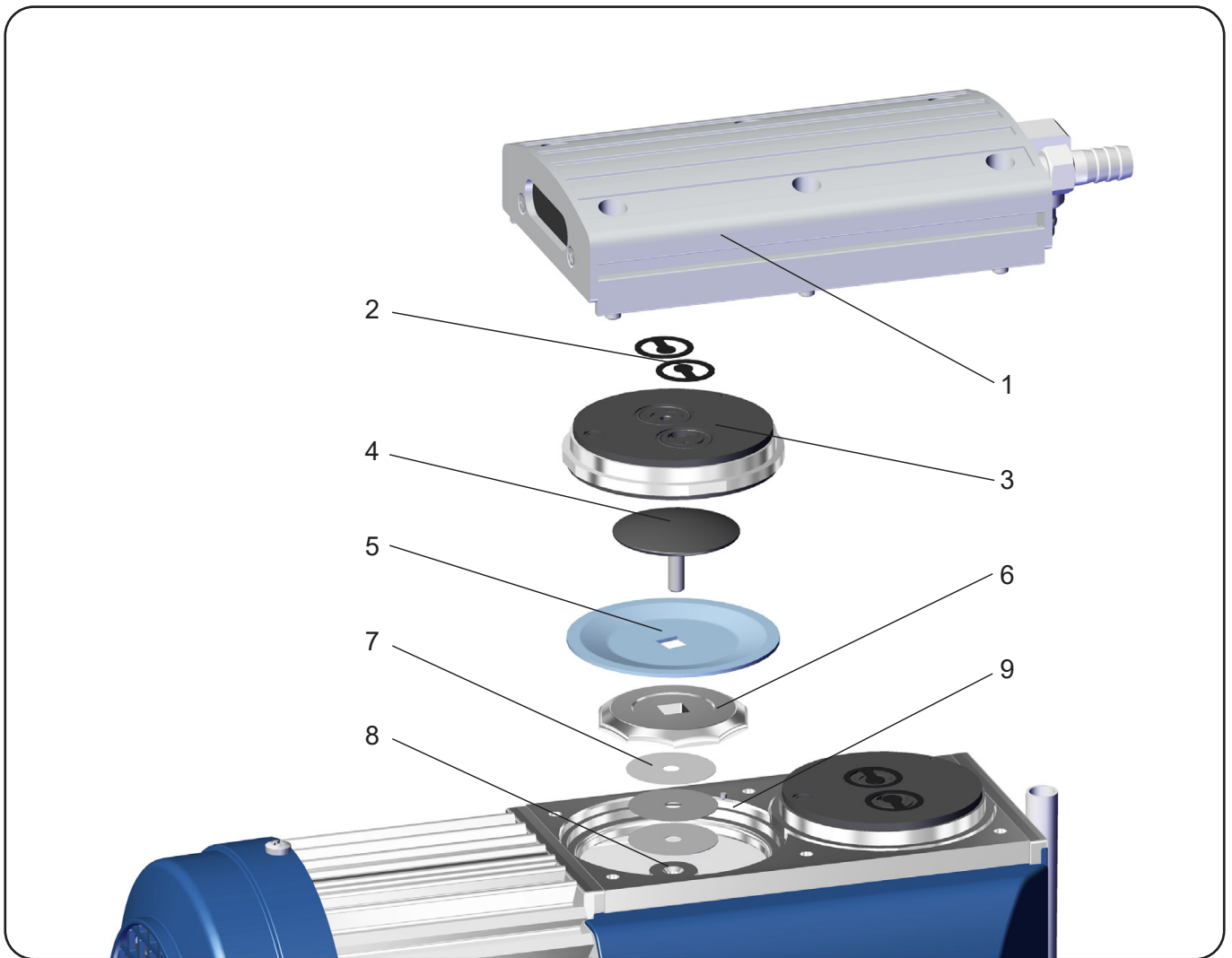

Position	Component
1	Housing cover with insert
2	Valves
3	Head cover
4	Diaphragm clamping disc with square head screw
5	Diaphragm
6	Diaphragm support disc
7	Washers
8	Connecting rod
9	Housing

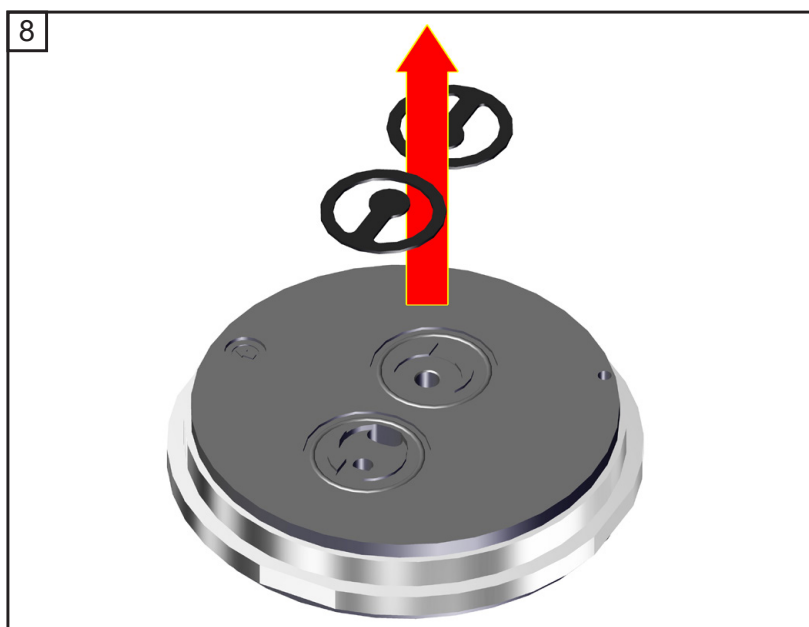
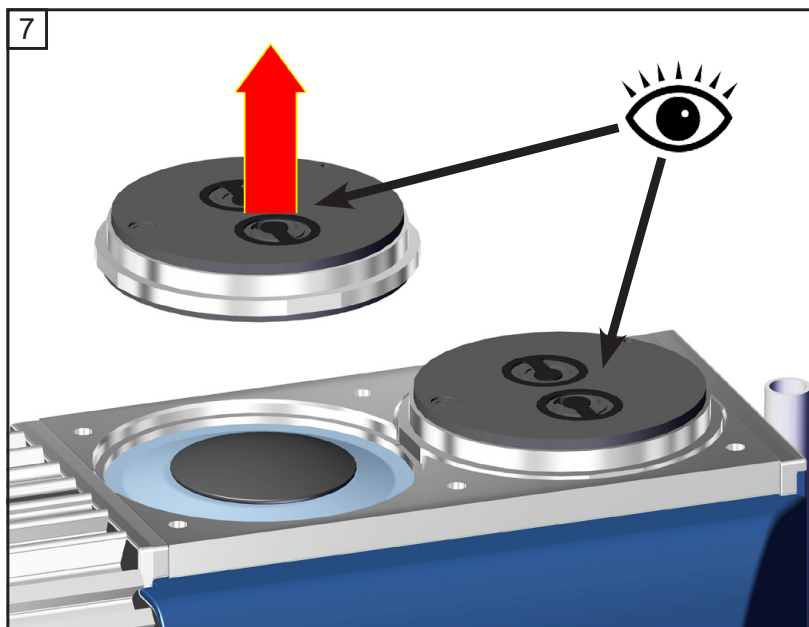
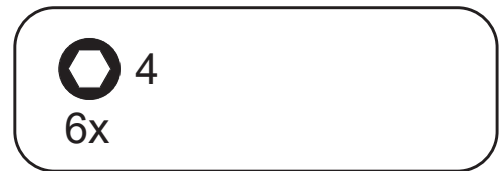
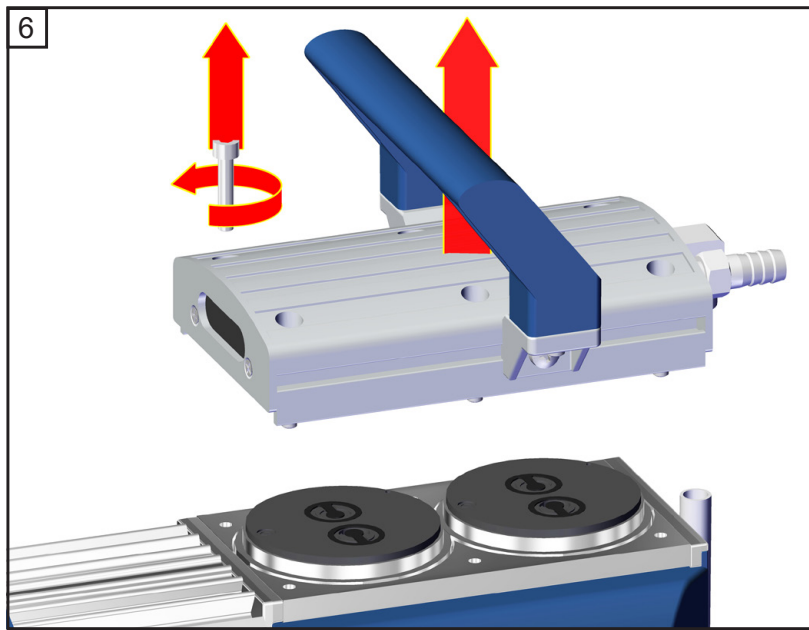

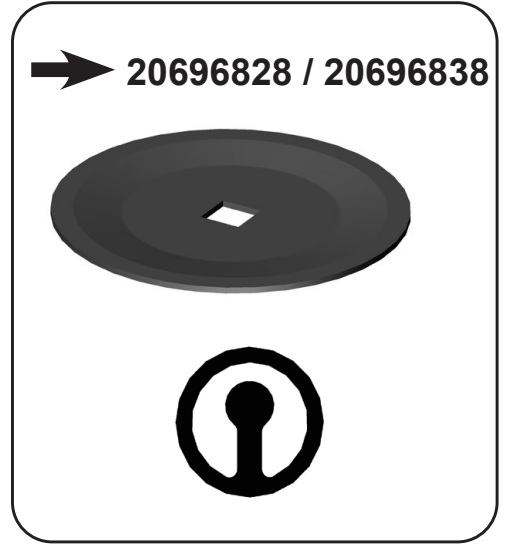
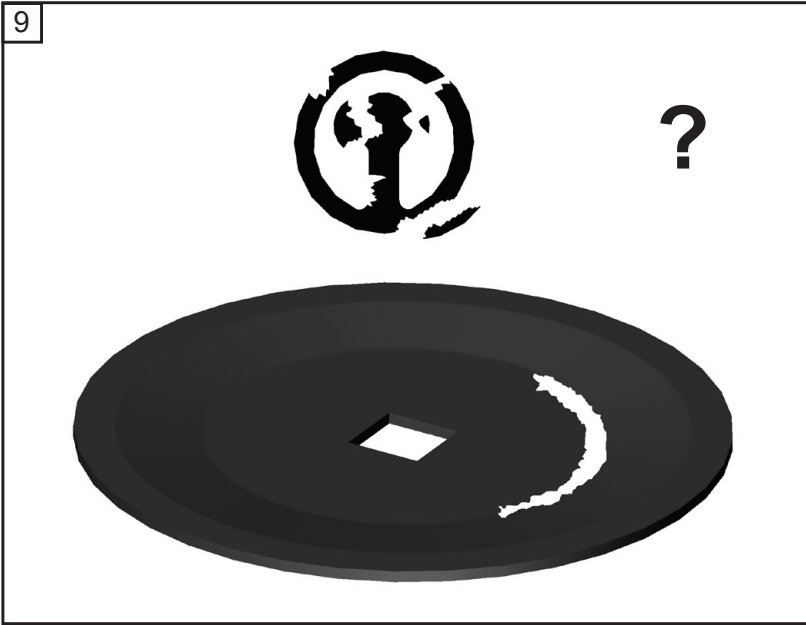

Replacing the diaphragm

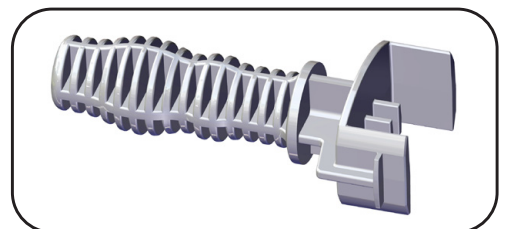
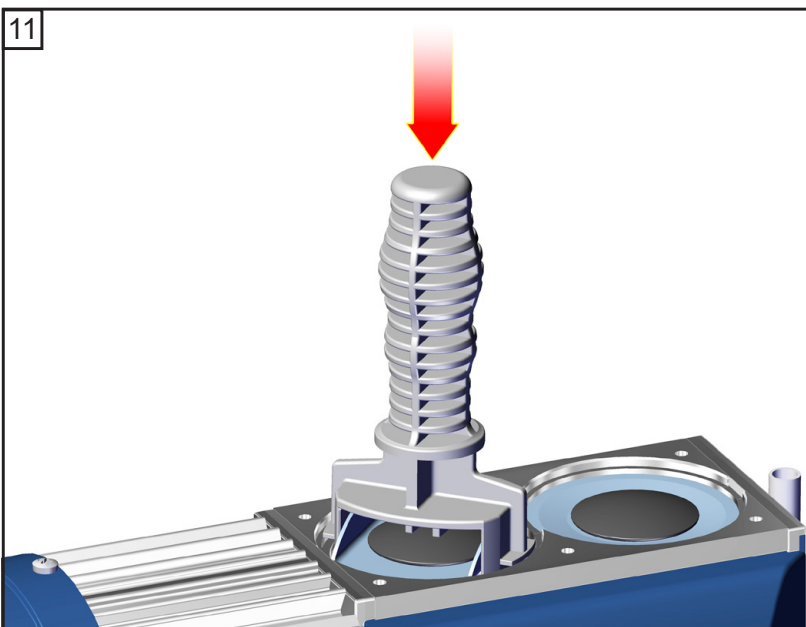
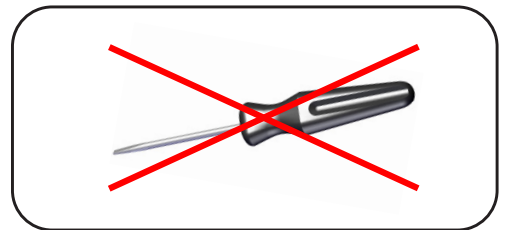
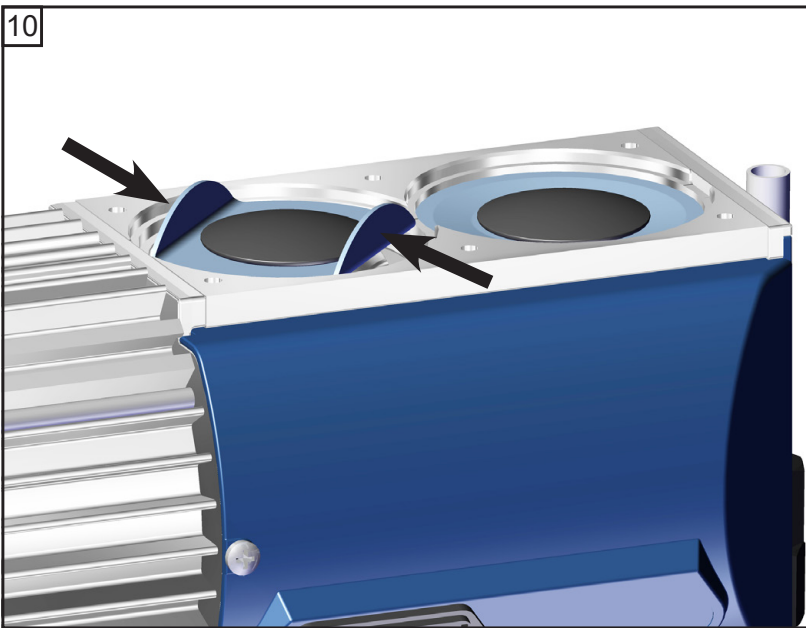

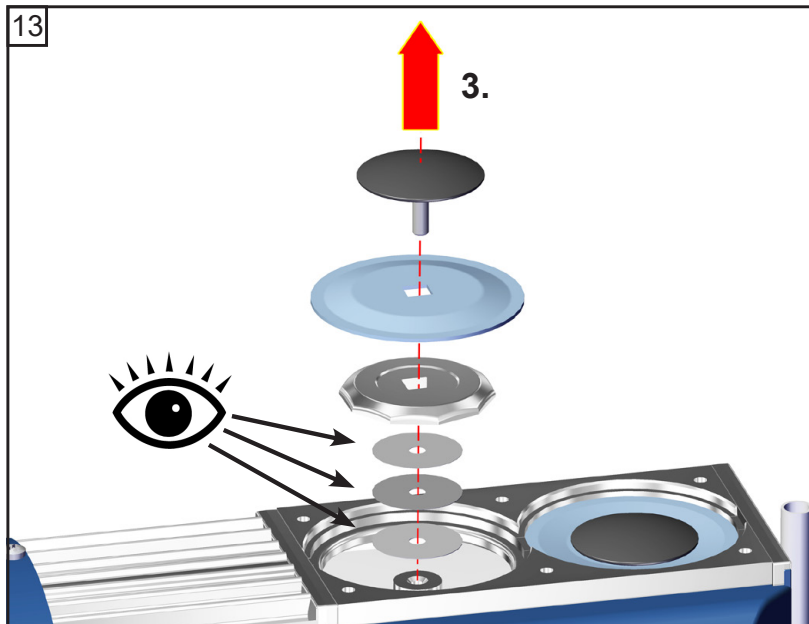
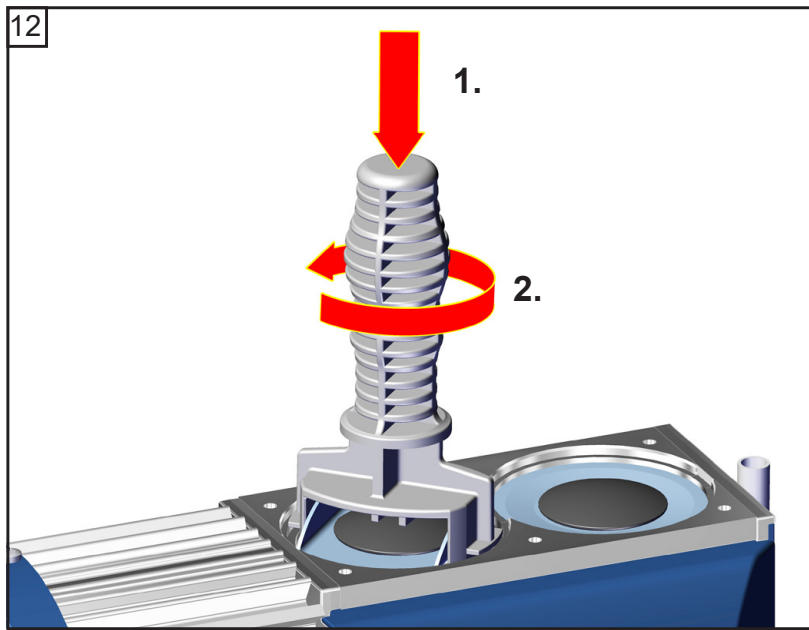

☞ Pay attention to number of washers!

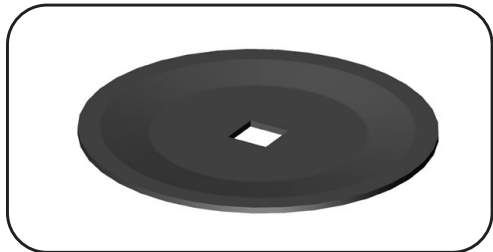
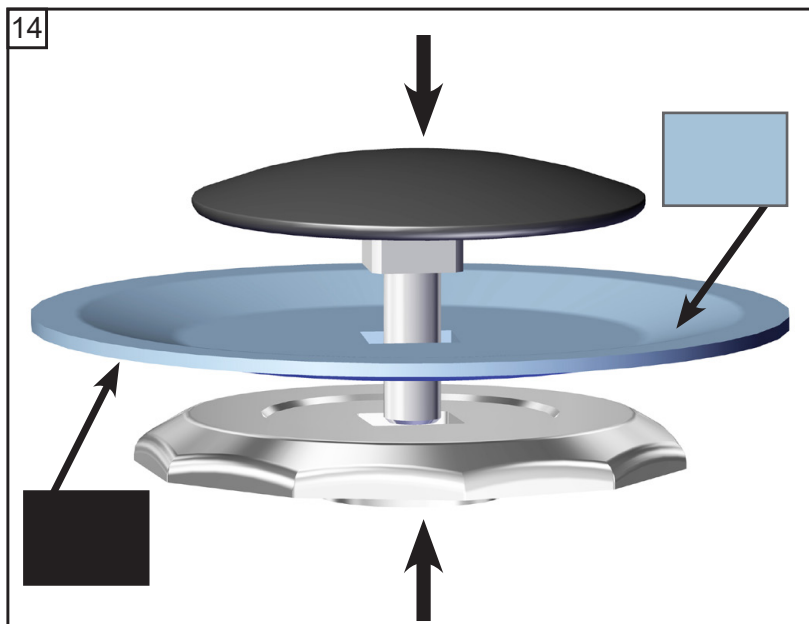

15

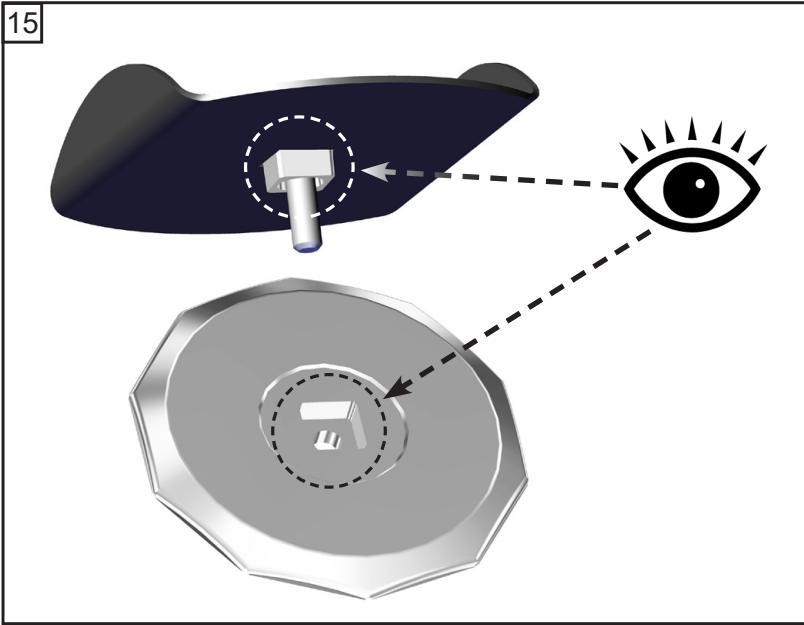

16

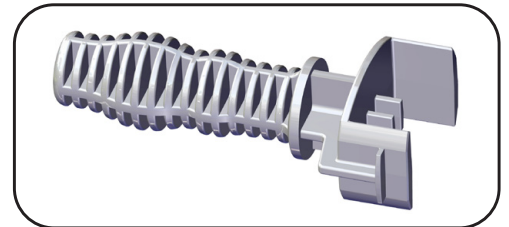
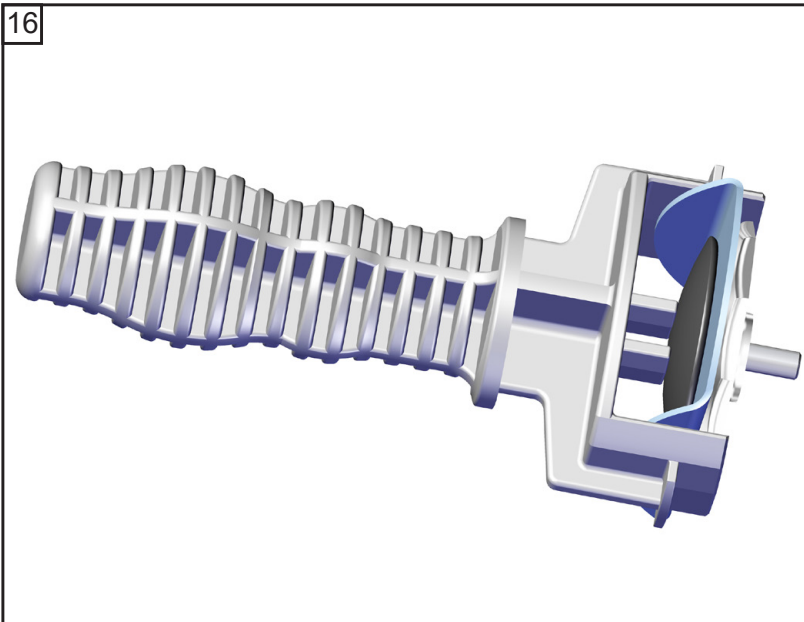

17

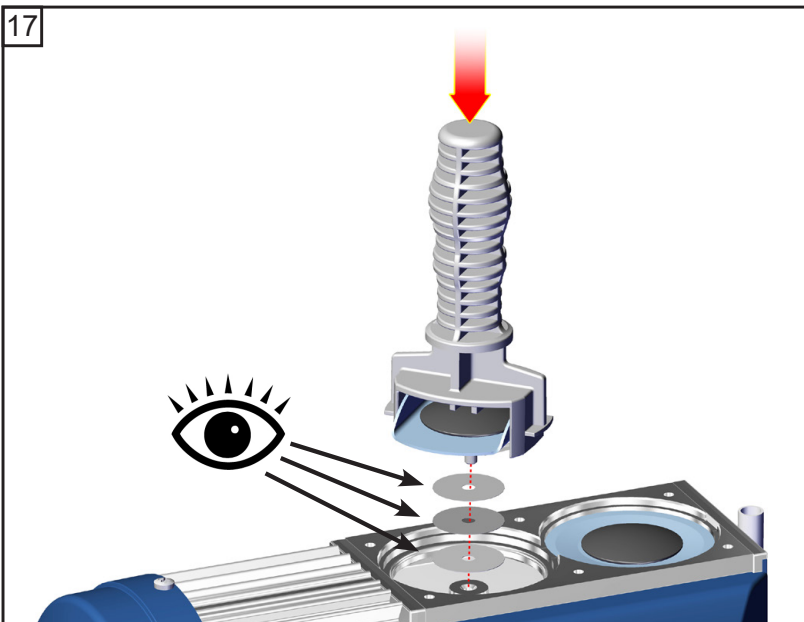

☞ Pay attention to number of washers!

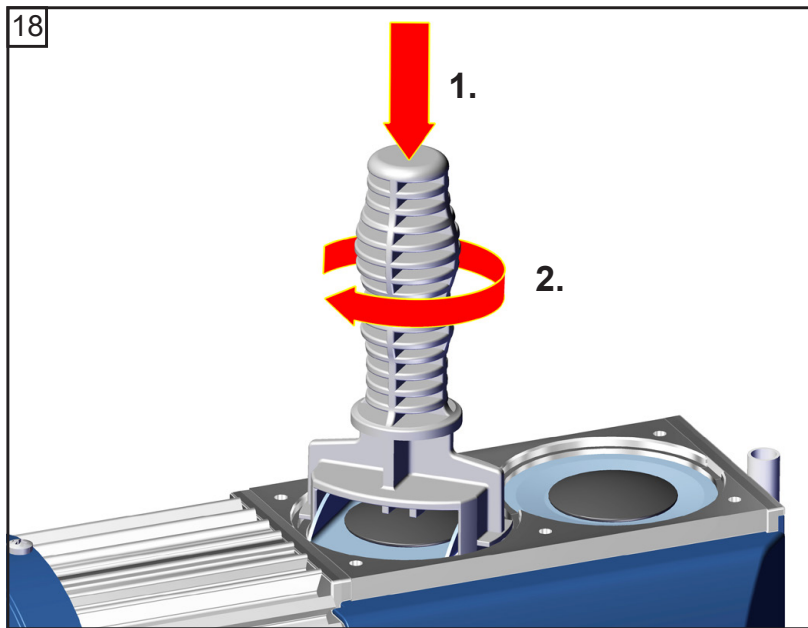

Replacing the valves and assembling the pump heads

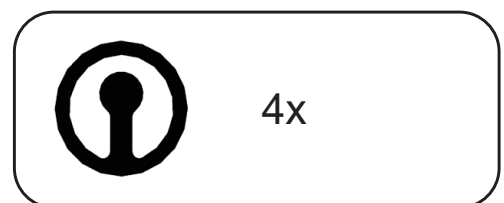
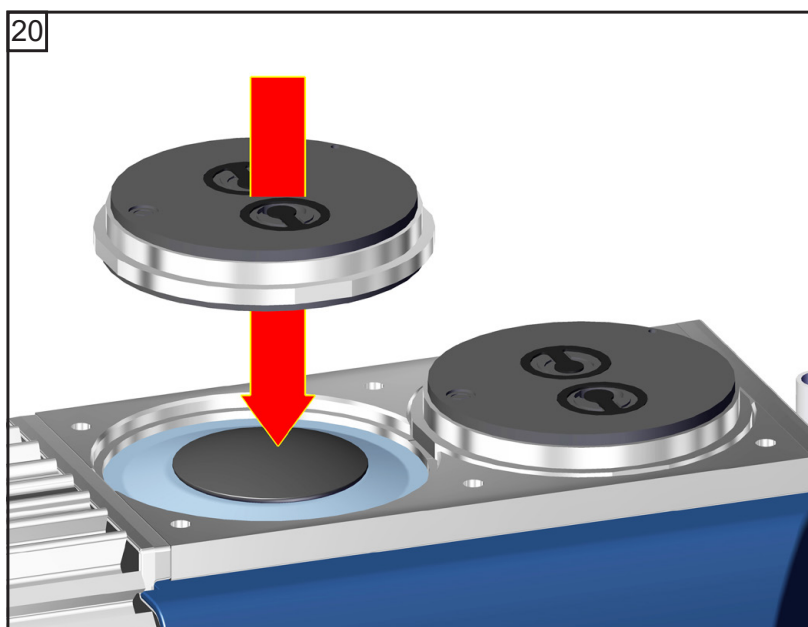
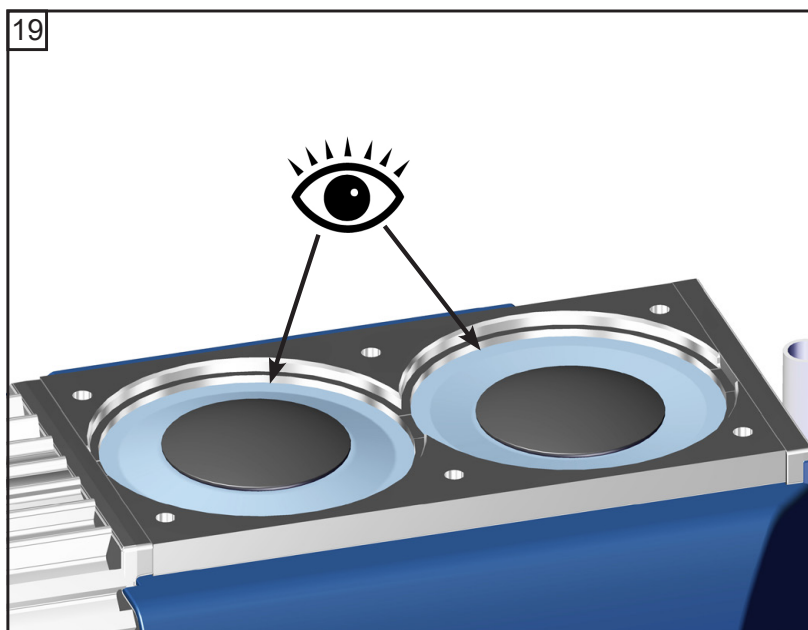

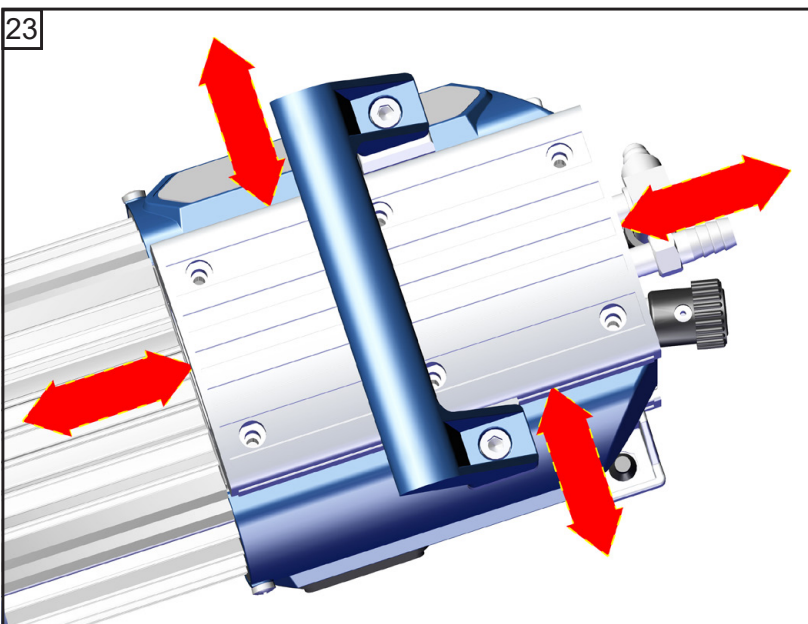
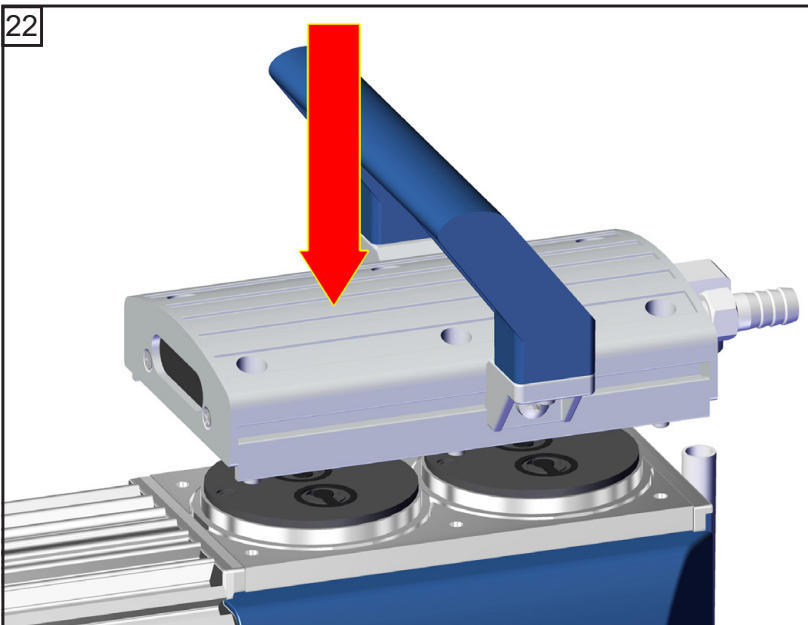
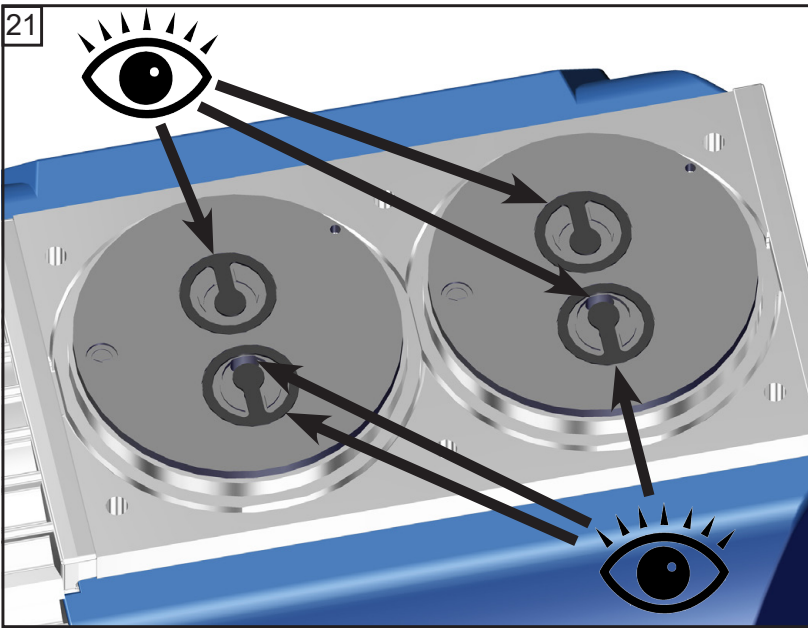

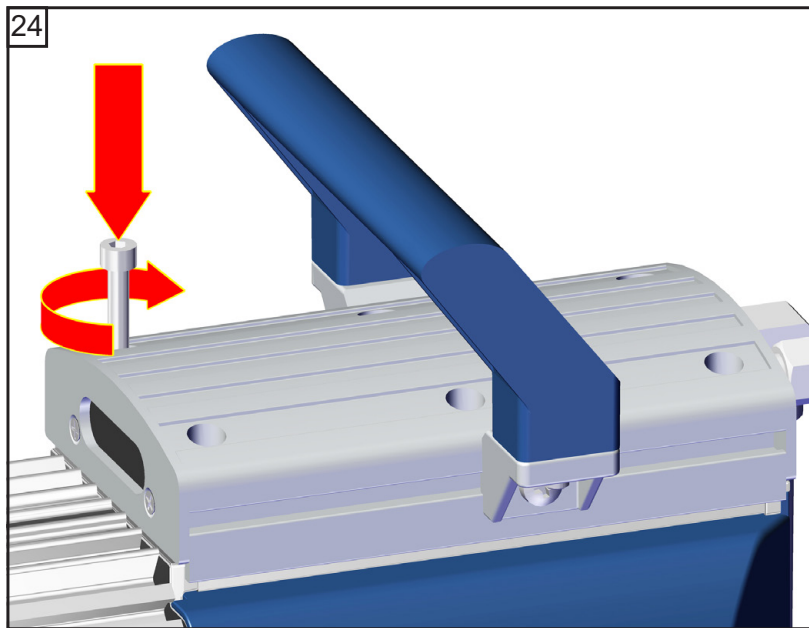

4
6x

☞ Screw in diagonally at first slightly, then tighten.

☞ **4.4 ft.lbf (6 Nm)**

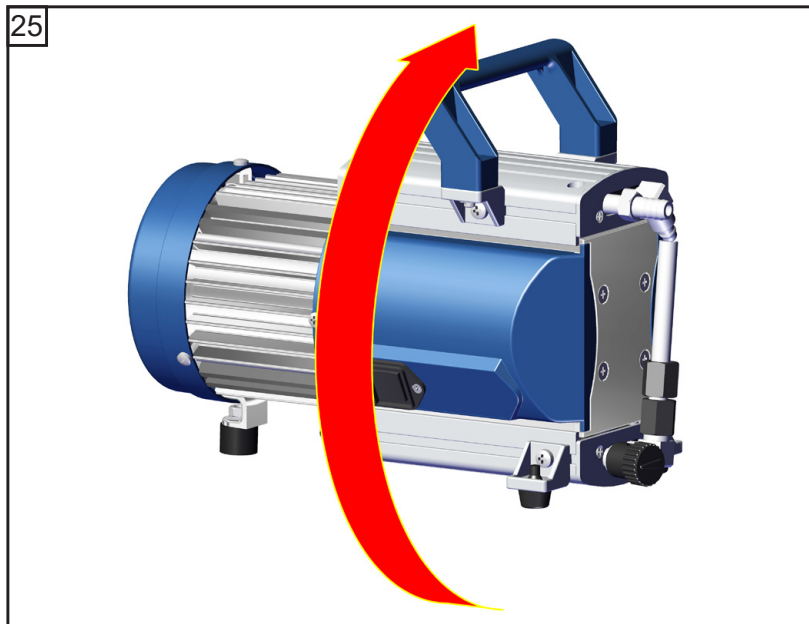

☞ Maintain all pump heads in the same way.

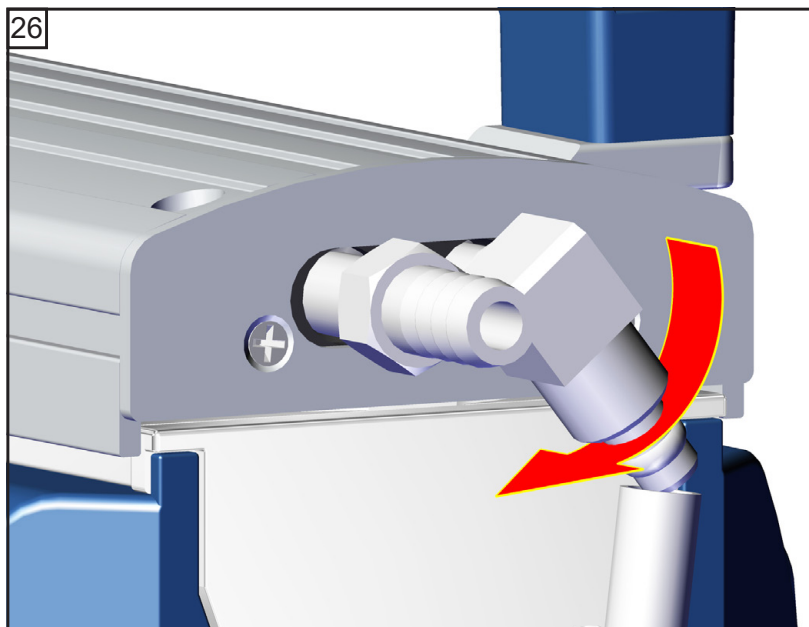

14 mm ↻ 1/4

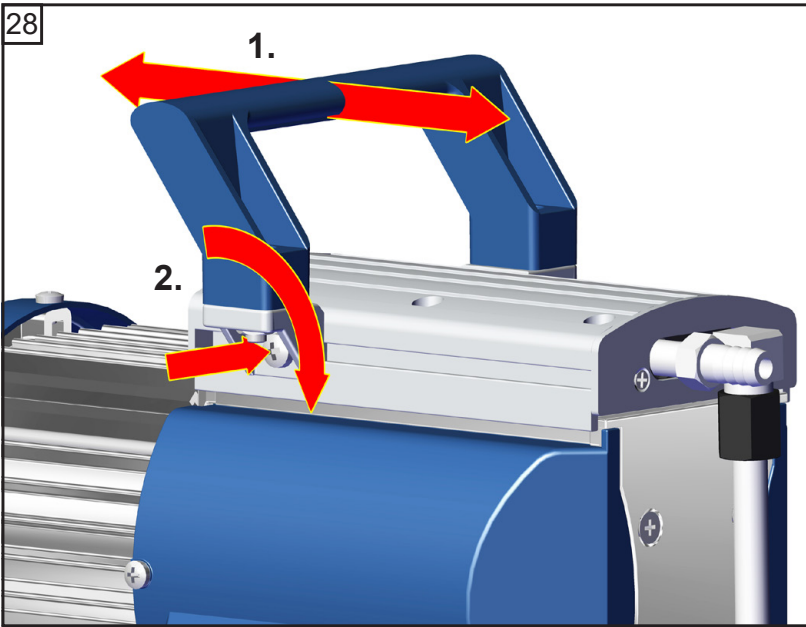
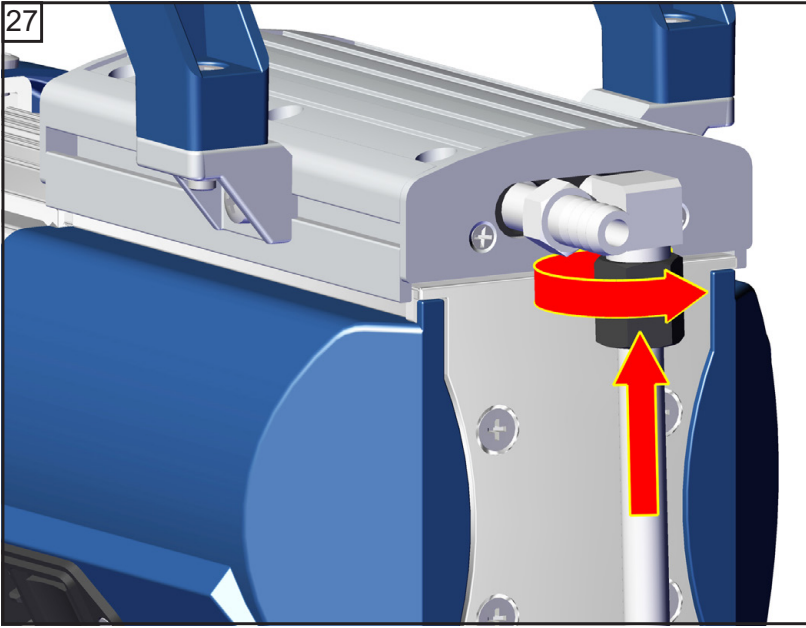

MD 1C

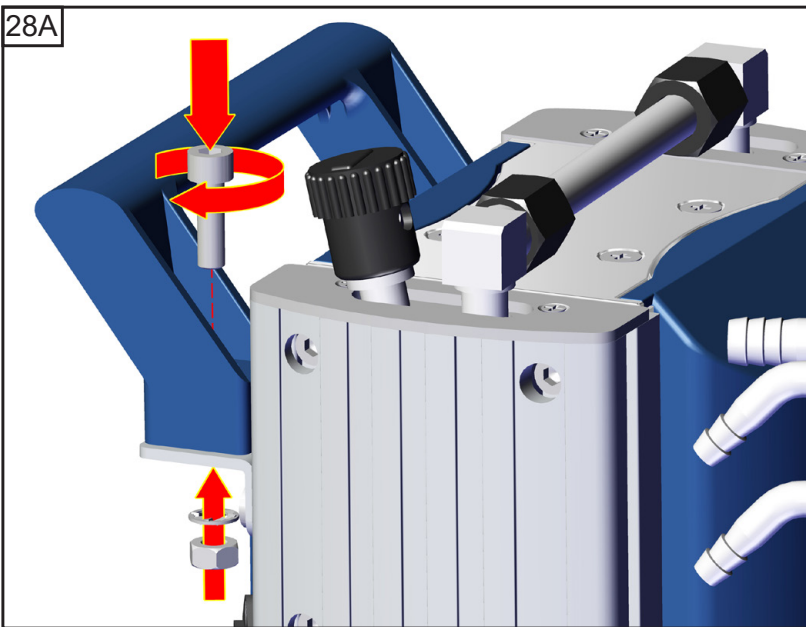
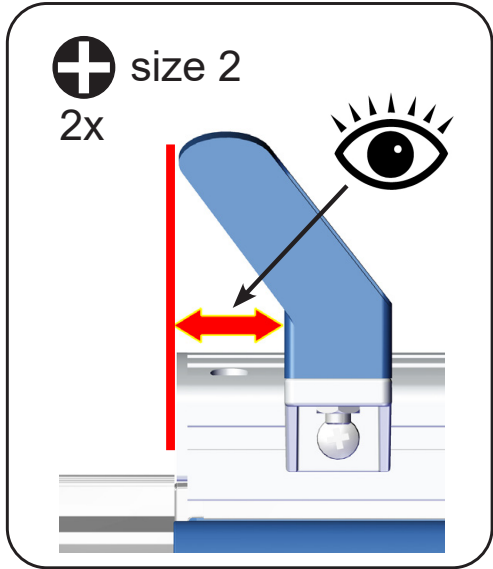

MD 1C + AK + EK



Assembling the connecting hose (MD 1C + AK + EK)

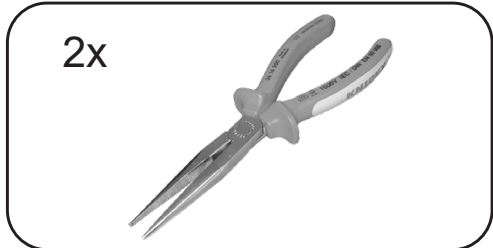
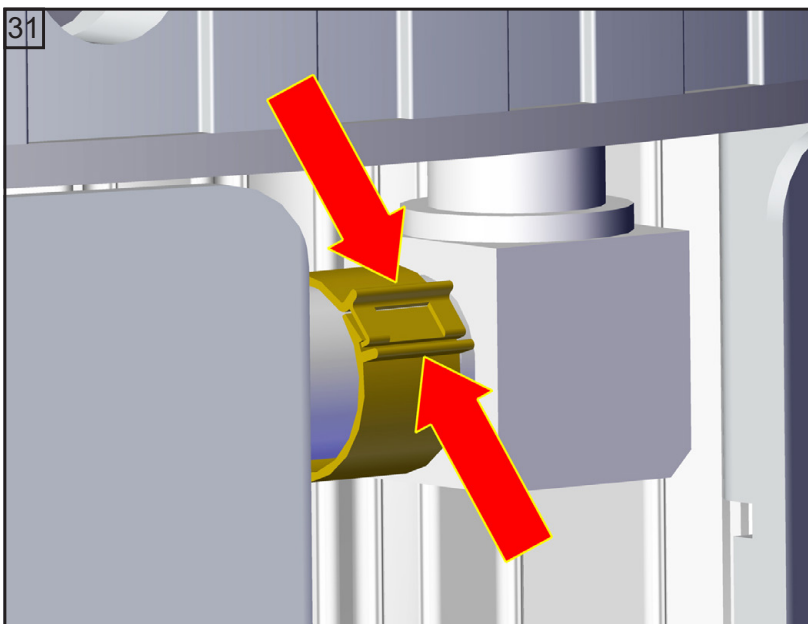
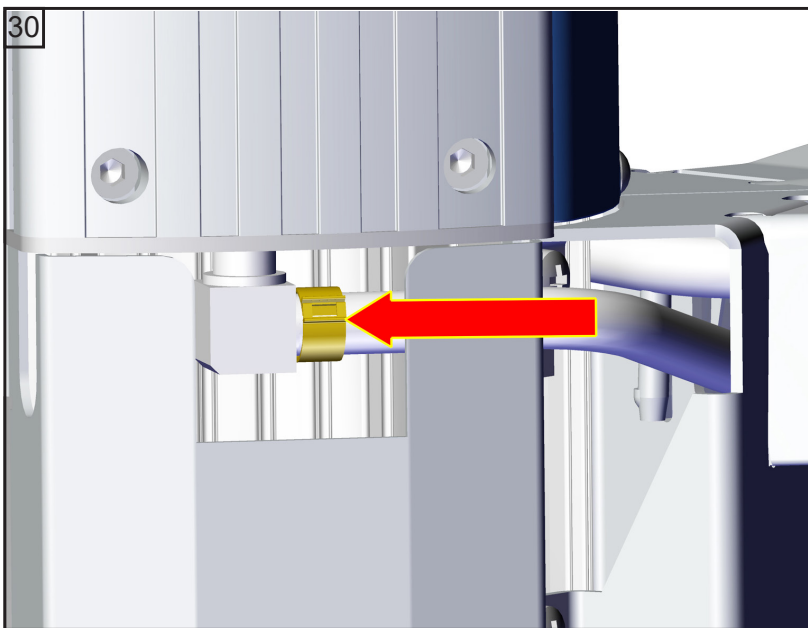
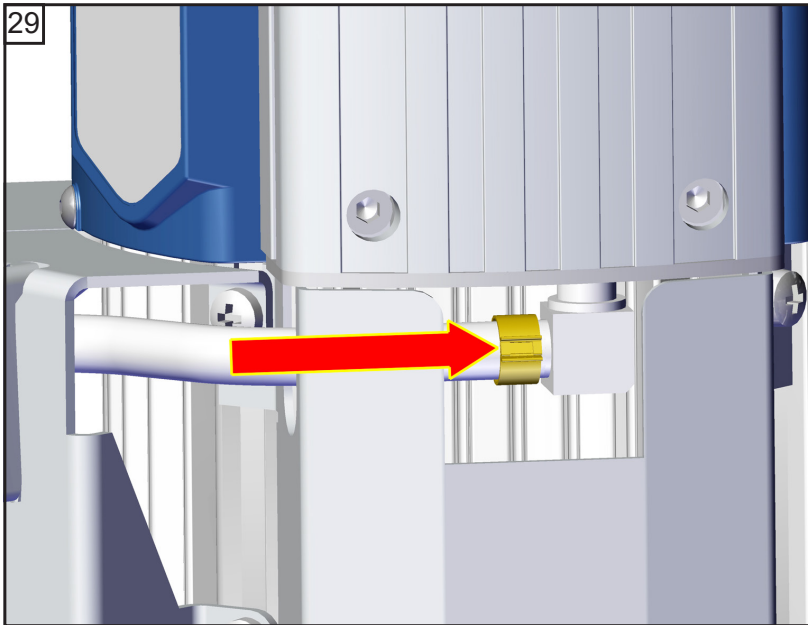

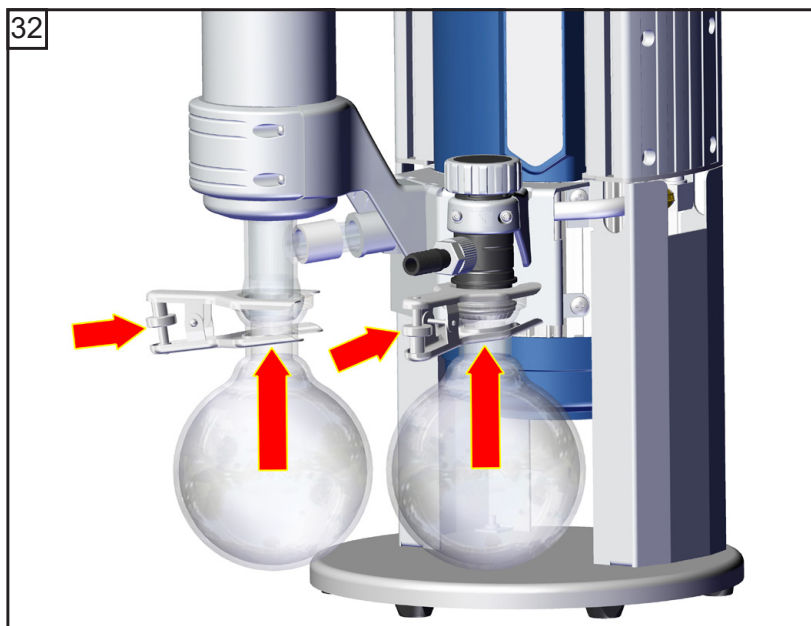

Checking the ultimate vacuum

- ➔ After any intervention at the equipment (e.g., repair / maintenance) the ultimate vacuum of the pump has to be checked. Only if the pump achieves its specified ultimate vacuum, the pump's leak rate is low enough to ensure that no explosive atmospheres will occur in the interior of the equipment.

If the pump does not achieve the ultimate vacuum:

- Whenever the diaphragms and valves have been replaced, a break-in period of several hours is required before the pump achieves its ultimate vacuum.
- In case of an unusual noise, switch off pump immediately and check clamping disc positions.

If the specified ultimate vacuum is not achieved, and if this does not change after the break-in period:

Check hose connectors at pump heads for leaks. If necessary recheck valve seats and pump chambers.

Replacing the overpressure safety relief device at the exhaust waste vapor condenser

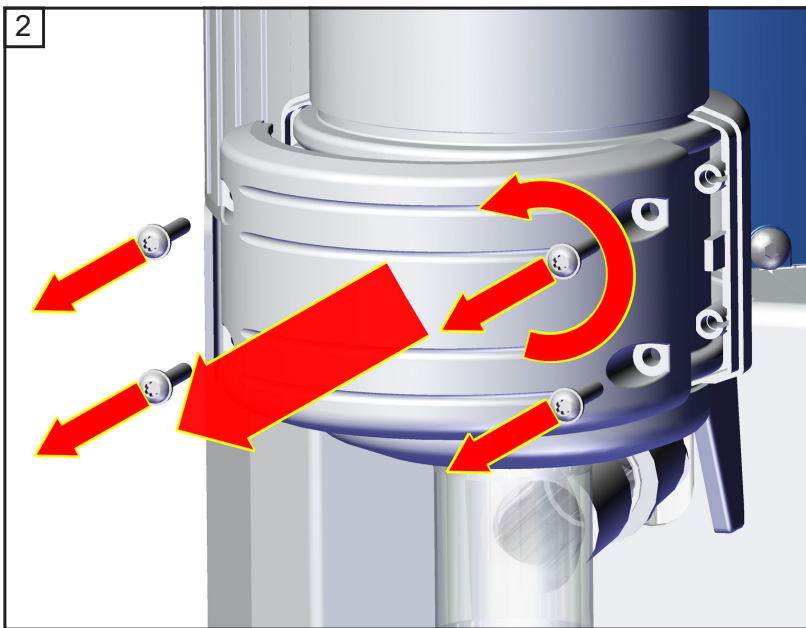
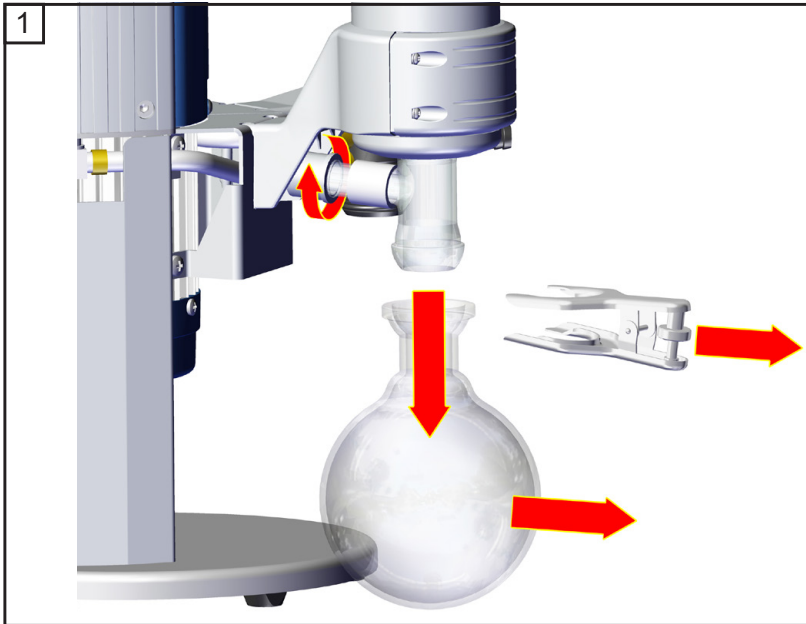

 T20
4x

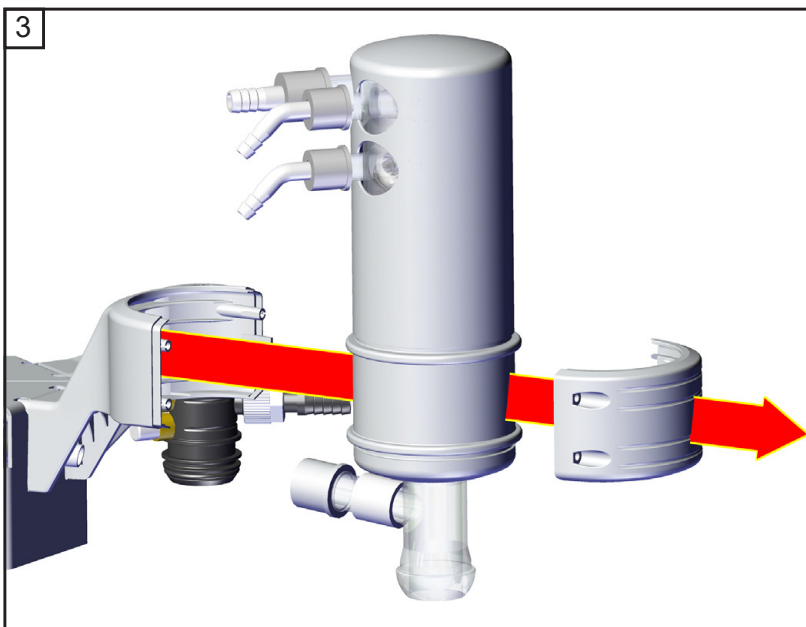

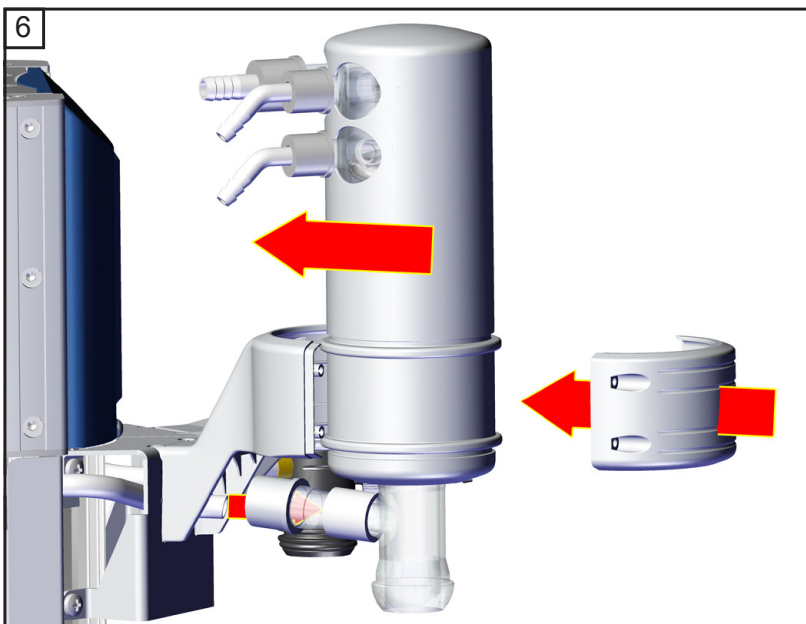
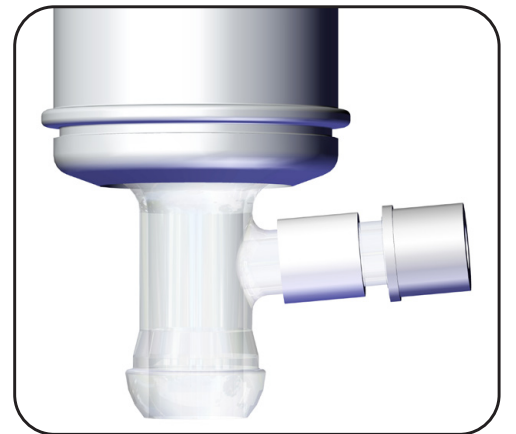
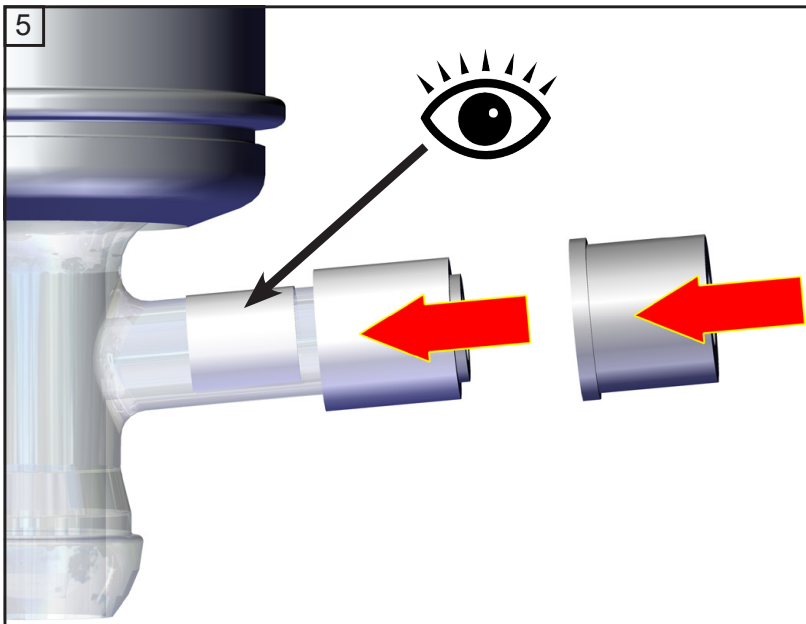
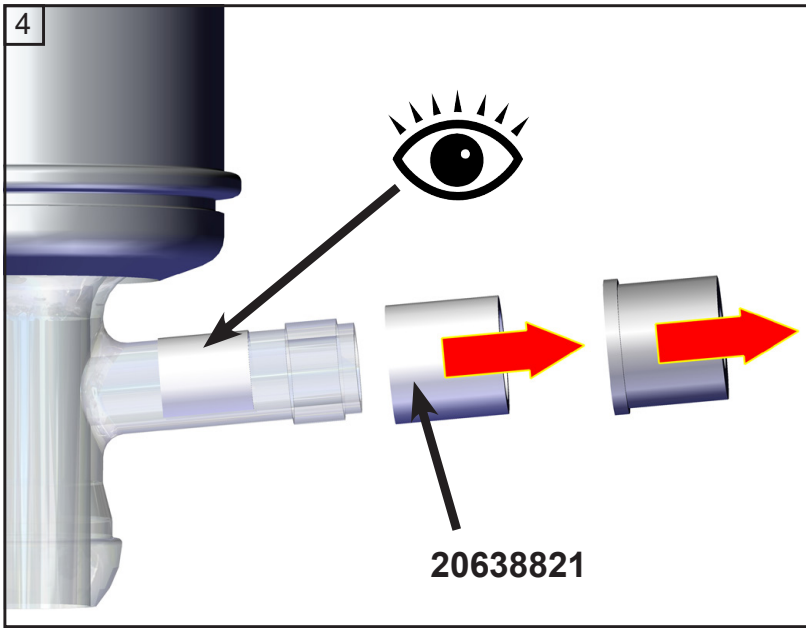

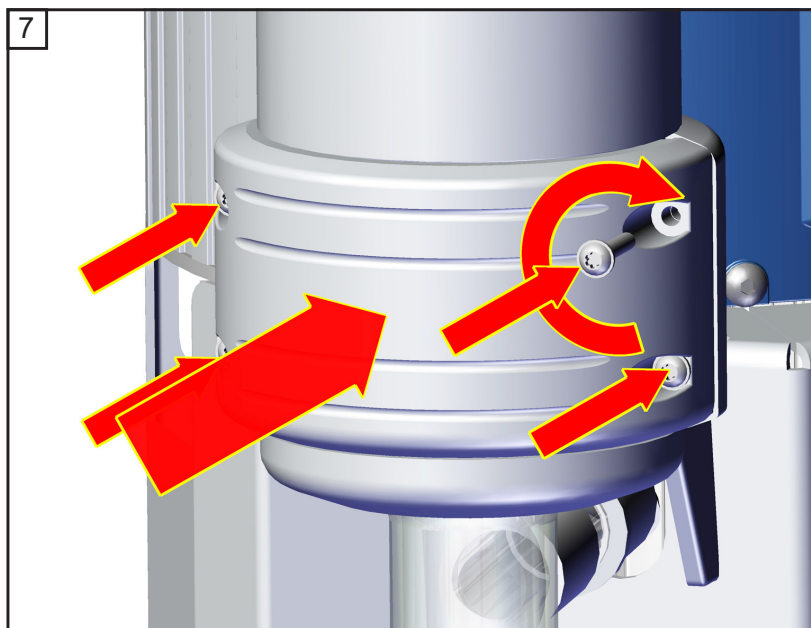

 T20
4x

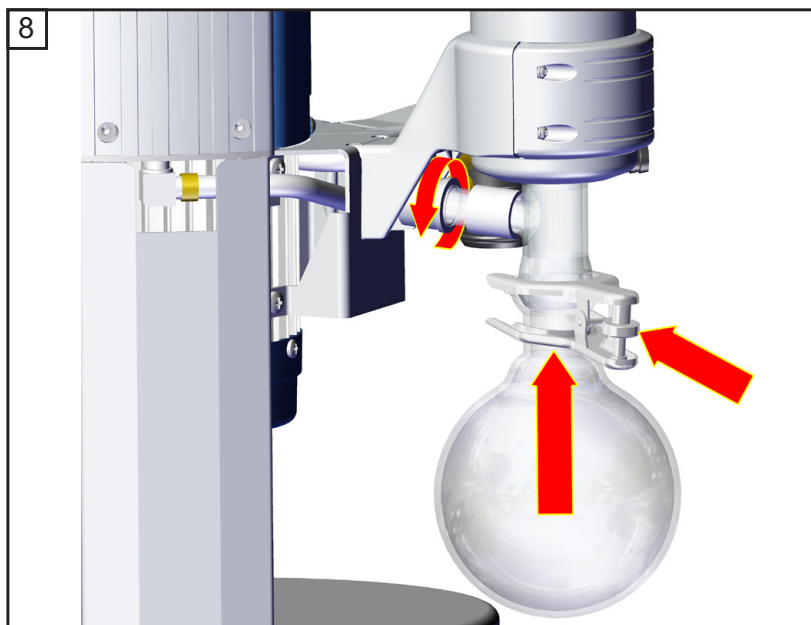

Spare parts MD 1C + AK + EK



- Catchpot
0.52 qt (500 ml), coated**20638497**
- O-ring 28 x 2.5**20635628**
at the spherical ground joint of the catchpot at the
inlet

Repair - Maintenance - Return - Calibration

IMPORTANT

Every employer (user) is held responsible for the health and safety of his employees. This also applies to service personnel performing repair, maintenance, return or calibration.

The **health and safety clearance form** informs the contractor about any possible contamination of the device and forms the basis for the risk assessment.

In case of devices which have been in contact with biological substances of risk level 2 contact the VACUUBRAND service absolutely before dispatching the device. These devices have to be completely disassembled and decontaminated by the user prior to shipment. Do not return devices which have been in contact biological substances of risk level 3 or 4. These devices cannot be checked, maintained or repaired. Also decontaminated devices must not returned to VACUUBRAND due to a residual risk. The same conditions apply to on-site work.

No repair, maintenance, return or calibration is possible unless the correctly completed health and safety clearance form is returned. Devices sent are rejected if applicable. Send a completed copy of the **health and safety clearance form** to us in advance. The declaration must arrive before the equipment. Enclose a second completed copy with the product.

Remove all components from the device that are no original VACUUBRAND components. VACUUBRAND will not be responsible for lost or damaged components that are no original components.

Drain the device completely of fluids and residues. Decontaminate the device. Close all openings airtight especially if using substances hazardous to health.

To expedite repair and to reduce costs, please enclose a detailed description of the problem and the product's operating conditions with every product returned.

If you do not wish a repair on the basis of our **quotation**, the device may be returned to you disassembled and at your expense.

In many cases, the components must be cleaned in the factory prior to repair.

For cleaning we use an environmentally friendly water based process. Unfortunately the combined attack of elevated temperature, cleaning agent, ultrasonic treatment and mechanical stress (from pressurised water) may result in damage to the paint. Please mark in the health and safety clearance form if you wish a repaint at your expense just in case such a damage should occur. We will also replace parts for cosmetic reasons at your request and at your expense.

Before returning the device

Pack the device properly, if necessary, please order original packaging materials at your costs. Mark the package completely

Enclose the completed health and safety clearance form.

Notify the carrier of any possible contamination if required.

Scrapping and waste disposal

Dispose of the equipment and any components removed from it safely in accordance with all local and national safety and environmental requirements. Particular care must be taken with components and waste oil which have been contaminated with dangerous substances from your processes. Do not incinerate fluoroelastomer seals and O-rings. You may authorize us to dispose of the equipment **at your expense**. Otherwise we return the device at your expense.

Warranty

VACUUBRAND shall be liable for insuring that this product, including any agreed installation, has been free of defects at the time of the transfer of risk.

VACUUBRAND shall not be liable for the consequences of improper handling, use, servicing or operation of this product or the consequences of normal wear and tear of wearing parts such as diaphragms, seals, valves, vanes, condensers, oil and the breakage of glass or ceramic parts, for the consequences of chemical, electrochemical or electrical influences or the failure to follow the instructions in this manual.

Claims for defects against VACUUBRAND shall be limited to one year from delivery. The same shall apply to claims for damages irrespective of legal grounds.

For further information on general terms and conditions refer to www.vacuubrand.com.

Health and safety clearance form

1. Device (Model):

2. Serial no.:

3. Reason for return / malfunction:

4. Has the device been used in a copper process step (e.g., semiconductor production): yes no

5. Substances (gases, liquids, solids, biological material, e. g. bacteria, viruses) in contact with the device / which have been pumped:

.....
.....
.....

6. Risk level of the used biological material: none 1 2* 3** 4**

* Contact the VACUUBRAND service absolutely before dispatching the device.

** Devices which have been in contact with biological substances of risk level 3 or 4 cannot be checked, maintained or repaired. Also decontaminated devices must not returned to VACUUBRAND due to a residual risk.

7. Radioactive contamination: yes no

8. Prior to return to the factory the device has been decontaminated: yes no

Description of the decontamination method and the test / verification procedure:

.....
.....

9. All parts of the device are free of hazardous, harmful substances: yes no

10. Protective measures required for service staff:

.....

11. If the paint is damaged, we wish a repaint or a replacement of parts for reason of appearance (repaint and replacement at customer's expense): yes no

12. Legally binding declaration

We assure for the returned device that all substances, which have been in contact with the device are listed in section 5 and that the information is complete and that we have not withheld any information. We declare that all measures - where applicable - have been taken listed in section "Repair - Maintenance - Return - Calibration". By our signature below, we acknowledge that we accept liability for any damage caused by providing incomplete or incorrect information and that we shall indemnify VACUUBRAND from any claims as regards damages from third parties. We are aware that as expressed in § 823 BGB (Public Law Code of Germany) we are directly liable for injuries or damages suffered by third parties, particularly VACUUBRAND employees occupied with handling/repairing the product. Shipping of the device must take place according to regulations.

Name: Signature:

Job title: Company's seal:

Date:

Release for repair grant by VACUUBRAND (date / signature):.....
Protective measures: Protective gloves, safety goggles Hood External cleaning



EG-Konformitätserklärung für Maschinen
EC Declaration of Conformity of the Machinery
Déclaration CE de conformité des machines



Hersteller / Manufacturer / Fabricant:

VACUUBRAND GMBH + CO KG · Alfred-Zippe-Str. 4 · 97877 Wertheim · Germany

Hiermit erklärt der Hersteller, dass das Gerät konform ist mit den Bestimmungen der Richtlinien:

Hereby the manufacturer declares that the device is in conformity with the directives:

Par la présente, le fabricant déclare, que le dispositif est conforme aux directives:

- 2006/42/EG
- 2014/34/EU
- 2011/65/EU, 2015/863

Membranvakuumpumpe / Diaphragm vacuum pump / Pompe à membrane:

Typ / Type / Type: **MD 1C / MD 1C + AK + EK**

Artikelnummer / Order number / Numéro d'article: **20696600, 20696601, 20696602, 20696603 /
 20696620, 20696621, 20696622**

Seriennummer / Serial number / Numéro de série: Siehe Typenschild / See rating plate / Voir plaque signalétique

Angewandte harmonisierte Normen / Harmonized standards applied / Normes harmonisées utilisées:

DIN EN ISO 12100:2011, DIN EN 61010-1:2020, IEC 61010-1:2010 (Ed. 3), DIN EN 1012-2:2011

DIN EN 1127-1:2019; DIN EN ISO 80079-36:2016

DIN EN IEC 63000:2019

Bevollmächtigter für die Zusammenstellung der technischen Unterlagen / Person authorised to compile the technical file / Personne autorisée à constituer le dossier technique:

Dr. F. Gitmans · VACUUBRAND GMBH + CO KG · Germany

Ort, Datum / place, date / lieu, date: Wertheim, 11.08.2021



 (Dr. F. Gitmans)
 Geschäftsführer / Managing Director /
 Gérant



 ppa.
 (J. Kaibel)
 Technischer Leiter / Technical Director /
 Directeur technique

VACUUBRAND GMBH + CO KG

Alfred-Zippe-Str. 4
 97877 Wertheim

Tel.: +49 9342 808-0

Fax: +49 9342 808-5555

E-Mail: info@vacuubrand.com

Web: www.vacuubrand.com



EG-Konformitätserklärung für Maschinen
EC Declaration of Conformity of the Machinery
Déclaration CE de conformité des machines



Hersteller / Manufacturer / Fabricant:

VACUUBRAND GMBH + CO KG · Alfred-Zippe-Str. 4 · 97877 Wertheim · Germany

Hiermit erklärt der Hersteller, dass das Gerät konform ist mit den Bestimmungen der Richtlinien:

Hereby the manufacturer declares that the device is in conformity with the directives:

Par la présente, le fabricant déclare, que le dispositif est conforme aux directives:

- 2006/42/EG
- 2014/30/EU
- 2014/34/EU
- 2011/65/EU, 2015/863

Membranvakuumpumpe / Diaphragm vacuum pump / Pompe à membrane:

Typ / Type / Type: **MD 1C VARIO-SP**

Artikelnummer / Order number / Numéro d'article: **20696110, 20696112**

Seriennummer / Serial number / Numéro de série: Siehe Typenschild / See rating plate / Voir plaque signalétique

Angewandte harmonisierte Normen / Harmonized standards applied / Normes harmonisées utilisées:

DIN EN ISO 12100:2011, DIN EN 61010-1:2020, IEC 61010-1:2010 (Ed. 3), DIN EN 1012-2:2011

DIN EN 61326-1:2013

DIN EN 1127-1:2019; DIN EN ISO 80079-36:2016

DIN EN IEC 63000:2019

Bevollmächtigter für die Zusammenstellung der technischen Unterlagen / Person authorised to compile the technical file / Personne autorisée à constituer le dossier technique:

Dr. F. Gitmans · VACUUBRAND GMBH + CO KG · Germany

Ort, Datum / place, date / lieu, date: Wertheim, 11.08.2021



 (Dr. F. Gitmans)
 Geschäftsführer / Managing Director /
 Gérant



 ppa. (J. Kaibel)
 Technischer Leiter / Technical Director /
 Directeur technique

VACUUBRAND GMBH + CO KG

Alfred-Zippe-Str. 4
 97877 Wertheim

Tel.: +49 9342 808-0

Fax: +49 9342 808-5555

E-Mail: info@vacuubrand.com

Web: www.vacuubrand.com



Declaration of Conformity



Manufacturer:

VACUUBRAND GMBH + CO KG · Alfred-Zippe-Str. 4 · 97877 Wertheim · Germany

Hereby the manufacturer declares that the device is in conformity with the directives:

- Supply of Machinery (Safety) Regulations 2008 (S.I. 2008 No. 1597, as amended by S.I. 2019 No. 696)
- The Equipment and Protective Systems Intended for Use in Potentially Explosive Atmospheres Regulations 2016 (S.I. 2016 No. 1107, as amended by S.I. 2019 No. 696)
- The Restriction of the Use of Certain Hazardous Substances in Electrical and Electronic Equipment Regulations 2012 (S.I. 2012 No. 3032)

Diaphragm vacuum pump

Type: **MD 1C / MD 1C + AK + EK**

Order number: **20696600, 20696601, 20696602, 20696603 / 20696620, 20696621, 20696622**

Serial number: See rating plate

Harmonized standards applied:

EN ISO 12100:2010, EN 61010-1:2010+A1:2019, EN 1012-2:2010

EN 1127-1:2019, EN ISO 80079-36:2016

EN IEC 63000:2018

Person authorised to compile the technical file:

Dr. F. Gitmans · VACUUBRAND GMBH + CO KG · Germany

Place, date: Wertheim, 11.08.2021



 (Dr. F. Gitmans)
Managing Director

ppa. 

 (J. Kaibel)
Technical Director

VACUUBRAND GMBH + CO KG

Alfred-Zippe-Str. 4
97877 Wertheim

Tel.: +49 9342 808-0

Fax: +49 9342 808-5555

E-Mail: info@vacuubrand.com

Web: www.vacuubrand.com



Declaration of Conformity



Manufacturer:

VACUUBRAND GMBH + CO KG · Alfred-Zippe-Str. 4 · 97877 Wertheim · Germany

Hereby the manufacturer declares that the device is in conformity with the directives:

- Supply of Machinery (Safety) Regulations 2008
(S.I. 2008 No. 1597, as amended by S.I. 2019 No. 696)
- Electromagnetic Compatibility Regulations 2016
(S.I. 2016 No. 1091, as amended by S.I. 2019 No. 696)
- The Equipment and Protective Systems Intended for Use in Potentially Explosive Atmospheres Regulations 2016 (S.I. 2016 No. 1107, as amended by S.I. 2019 No. 696)
- The Restriction of the Use of Certain Hazardous Substances in Electrical and Electronic Equipment Regulations 2012 (S.I. 2012 No. 3032)

Diaphragm vacuum pump

Type: **MD 1C VARIO-SP**

Order number: **20696110, 20696112**

Serial number: See rating plate

Harmonized standards applied:

EN ISO 12100:2010, EN 61010-1:2010+A1:2019, EN 1012-2:2010

EN 61326-1:2013

EN 1127-1:2019, EN ISO 80079-36:2016

EN IEC 63000:2018

Person authorised to compile the technical file:

Dr. F. Gitmans · VACUUBRAND GMBH + CO KG · Germany

Place, date: Wertheim, 11.08.2021

(Dr. F. Gitmans)

Managing Director

ppa.

(J. Kaibel)

Technical Director

VACUUBRAND GMBH + CO KG

Alfred-Zippe-Str. 4
97877 Wertheim

Tel.: +49 9342 808-0

Fax: +49 9342 808-5555

E-Mail: info@vacuubrand.com

Web: www.vacuubrand.com

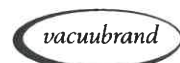



Certificate

Certificate no.

CU 72210918 01

License Holder:
 VACUUBRAND GMBH + CO KG
 Alfred-Zippe-Str. 4
 97877 Wertheim
 Deutschland

Manufacturing Plant:
 VACUUBRAND GMBH + CO KG
 Alfred-Zippe-Str. 4
 97877 Wertheim
 Deutschland

Test report no.: USA- 32195323 001

Client Reference: Dr. Wollschläger

Tested to: UL 61010-1:2012 R7.19

CAN/CSA-C22.2 NO. 61010-1-12 + GI1 + GI2 (R2017) + A1

Certified Product: Diaphragm vacuum pump for laboratory use

License Fee - Units

Models: Mw xxxxxxxx z 7
 w: E, Z, D or V
 x: 0.5, 1, 1.5, 2, 2x0.5, 2x1 or 4x0.5
 y: A-Z or blank
 z: +AK, +EK, +2AK, +Ak+EK, +AK+EK TE, +IK+EK,
 +AK+M+D, +AK+EK+M+D, +AK SYNCHRO+EK or blank

Ratings: AC 120V; 60Hz; 1.7A or
 AC 100-115V; 50/60Hz; 1.7A or
 AC 220-230 V; 50/60 Hz; 0.85 A
 (with voltage selector or fixed)

This certificate replaces certificate CU 72070564 01.

7

Appendix: 1, 1-9

Licensed Test mark:

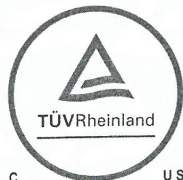

C US

Date of Issue

(day/mo/yr)

28/09/2021

TUV Rheinland of North America, Inc., 12 Commerce Road, Newtown, CT 06470, Tel (203) 426-0888 Fax (203) 426-4009

This certificate is only valid for pumps with the respective mark (Licensed Test mark) on the pump rating plate.

Certificate



Certificate no.

CU 72180259 01

License Holder:

VACUUBRAND GMBH + Co. KG
 Alfred-Zippe-Str. 4
 97877 Wertheim
 Germany

Manufacturing Plant:

VACUUBRAND GMBH + Co. KG
 Alfred-Zippe-Str. 4
 97877 Wertheim
 Germany

Test report no.: USA-JE 31880231 001

Client Reference: Dr. Wollschläger

Tested to:

UL 61010-1:2012 R4.16

CAN/CSA-C22.2 NO. 61010-1-12 + GI1 + GI2 (R2017)

Certified Product: Diaphragm Vacuum Pump for Laboratory Use**License Fee - Units**

Model Designation: Mx yzzzzz VARIO-SPzzzzz

7

x = E, Z, D, V

y = 0.5, 1, 1.5, 2x1, 2, 2x0.5, 4x0.5

z = A-Z, blank

Rated Voltage: DC 24 V

Rated Current: 7 A

Protection Class: III

7

Appendix: 1, 1 - 4

Licensed Test mark:**Date of Issue**

(day/mo/yr)

27/04/2018

This certificate is only valid for pumps with the respective mark (Licensed Test mark) on the pump rating plate.



DECLARATION OF CONFORMITY – China RoHS 2

VACUUBRAND GMBH + CO KG has made reasonable efforts to ensure that hazardous materials and substances may not be used in its products.

In order to determine the concentration of hazardous substances in all homogeneous materials of the subassemblies, a “Product Conformity Assessment” (PCA) procedure was performed. As defined in GB/T 26572 the “Maximum Concentration Value” limits (MCV) apply to these restricted substances:

- Lead (Pb): 0.1%
- Mercury (Hg): 0.1%
- Cadmium (Cd): 0.01%
- Hexavalent chromium (Cr(+VI)): 0.1%
- Polybrominated biphenyls (PBB): 0.1%
- Polybrominated diphenyl ether (PBDE): 0.1%

Environmentally Friendly Use Period (EFUP)



EFUP defines the period in years during which the hazardous substances contained in electrical and electronic products will not leak or mutate under normal operating conditions. During normal use by the user such electrical and electronic products will not result in serious environmental pollution, cause serious bodily injury or damage to the user's assets.

The Environmentally Friendly Use Period for VACUUBRAND products is 40 years.



此表格是按照SJ/T 11364-2014中规定所制定的。

This table is created according to SJ/T 11364-2014.

MATERIAL CONTENT DECLARATION FOR VACUUBRAND PRODUCTS							
部件名称 Part name	有毒有害物质或元素 Hazardous substances						环保期限标识 EFUP
	铅 Pb	汞 Hg	镉 Cd	六价铬 Cr(+VI)	多溴联苯 PBB	多溴二苯醚 PBDE	
包装 Packaging	○	○	○	○	○	○	
塑料外壳 / 组件 Plastic housing / parts	○	○	○	○	○	○	
真空油 Vacuum oil	○	○	○	○	○	○	
电池 Battery	○	○	○	○	○	○	
玻璃 Glass	X	○	○	○	○	○	
电子电气组件 Electrical and electronic parts	X	○	○	○	○	○	
控制器 / 测量设备 Controller / measuring device	X	○	○	○	○	○	
金属外壳 / 组件 Metal housing / parts	X	○	○	○	○	○	
电机 Motor	X	○	○	○	○	○	
配件 Accessories	X	○	○	○	○	○	



注释: 此表格适用于所有产品。以上列出的元件或组件不一定都属于所附产品的组成。

Note: Table applies to all products. Some of the components or parts listed above may not be part of the enclosed product.

- O: 表示该有毒有害物质在该部件所有均质材料中的含量均在GB/T 26572规定的限量要求以下。
 O: Indicates that the above mentioned hazardous substance contained in all homogeneous materials of the part is below the required limit as defined in GB/T 26572.
- X: 表示该有毒有害物质至少在该部件某一均质材料中的含量超出GB/T 26572规定的限量要求。
 X: Indicates that the above mentioned hazardous substance contained in at least one of the homogeneous materials of this part is above the required limit as defined in GB/T 26572.

除上表所示信息外，还需声明的是，这些部件并非是有意图用铅（Pb）、汞（Hg）、铬（Cd）、六价铬（Cr(+VI)）、多溴联苯（PBB）或多溴二苯醚（PBDE）来制造的。

Apart from the disclosures in the above table, the subassemblies are not intentionally manufactured or formulated with lead (Pb), mercury (Hg), cadmium (Cd), hexavalent chromium (Cr+VI), polybrominated biphenyls (PBB), and polybrominated diphenyl ethers (PBDE).

Products manufactured by VACUUBRAND may enter into further devices (e.g., rotary evaporator) or can be used together with other appliances (e.g., usage as booster pumps).

With these products and appliances in particular, please note the EFUP labeled on these products. VACUUBRAND will not take responsibility for the EFUP of those products and appliances.

Place, date: Wertheim, 06/04/2020

(Dr. F. Gitmans)
Managing Director

i.A. (Dr. A. Wollschläger)
Regulatory Affairs Manager

VACUUBRAND GMBH + CO KG
Alfred-Zippe-Str. 4
97877 Wertheim
Germany

Tel.: +49 9342 808-0
Fax: +49 9342 808-5555
E-Mail: info@vacuubrand.com
Web: www.vacuubrand.com

Disclaimer: Our technical literature is only intended to inform our customer. The applicability of general empirical values and results obtained under lab conditions to your specific operations depends on a number of factors beyond our control. It is, therefore, strictly the users' responsibility to very carefully check the application of these data to their specific requirements. No claims arising from the information provided in this literature will, consequently, be entertained.



Alfred-Zippe-Str. 4 · 97877 Wertheim / Germany
T +49 9342 808-0 · F +49 9342 808-5555
info@vacuubrand.com · www.vacuubrand.com

VACUUBRAND GMBH + CO KG
- Technology for Vacuum Systems -
© 2021 VACUUBRAND GMBH + CO KG Printed in Germany