

NOTES:

MATERIAL:
STEEL WITH 2.0mm LEAD EQUIVALENCE

PAD PRINT COLOR:
2.0mm LEAD EQUIVALENCE GLASS

FRAME COLOR:
TAN

NOT TO SCALE

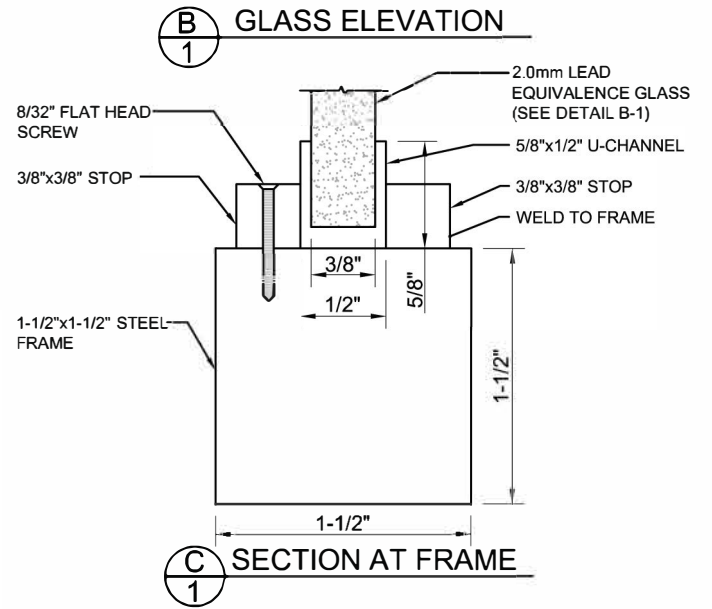
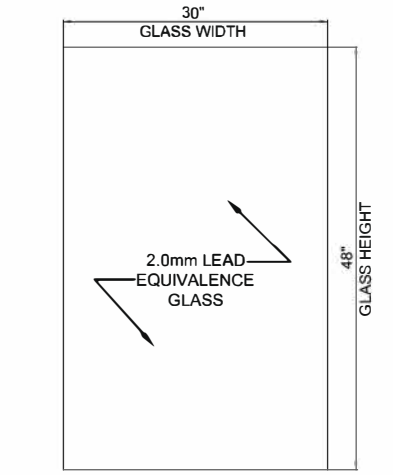
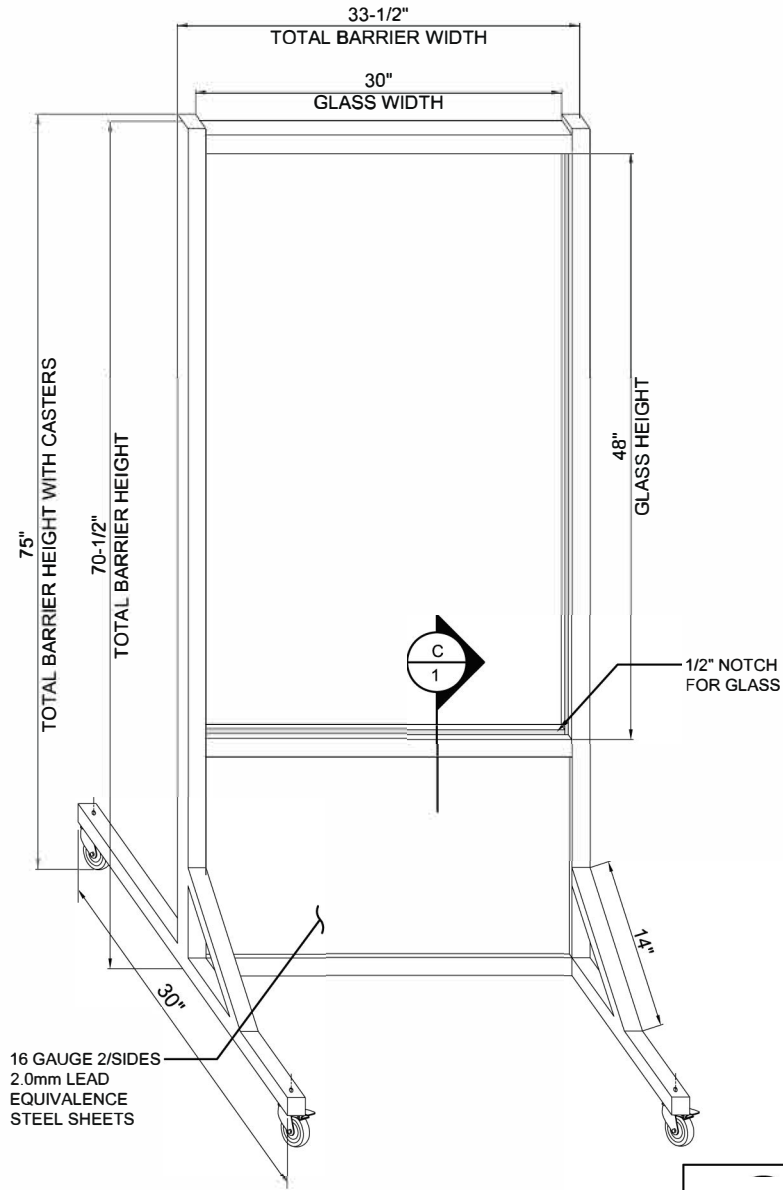

	DWG No.	LB-3048	Rev.
	P/N:	LB-3048	
	DESC.	Mobile Leaded Barrier w/48 inch Window	