

**GEORGETOWN MODEL
ADJUSTABLE HEIGHT
INSTRUMENTAL TABLE**

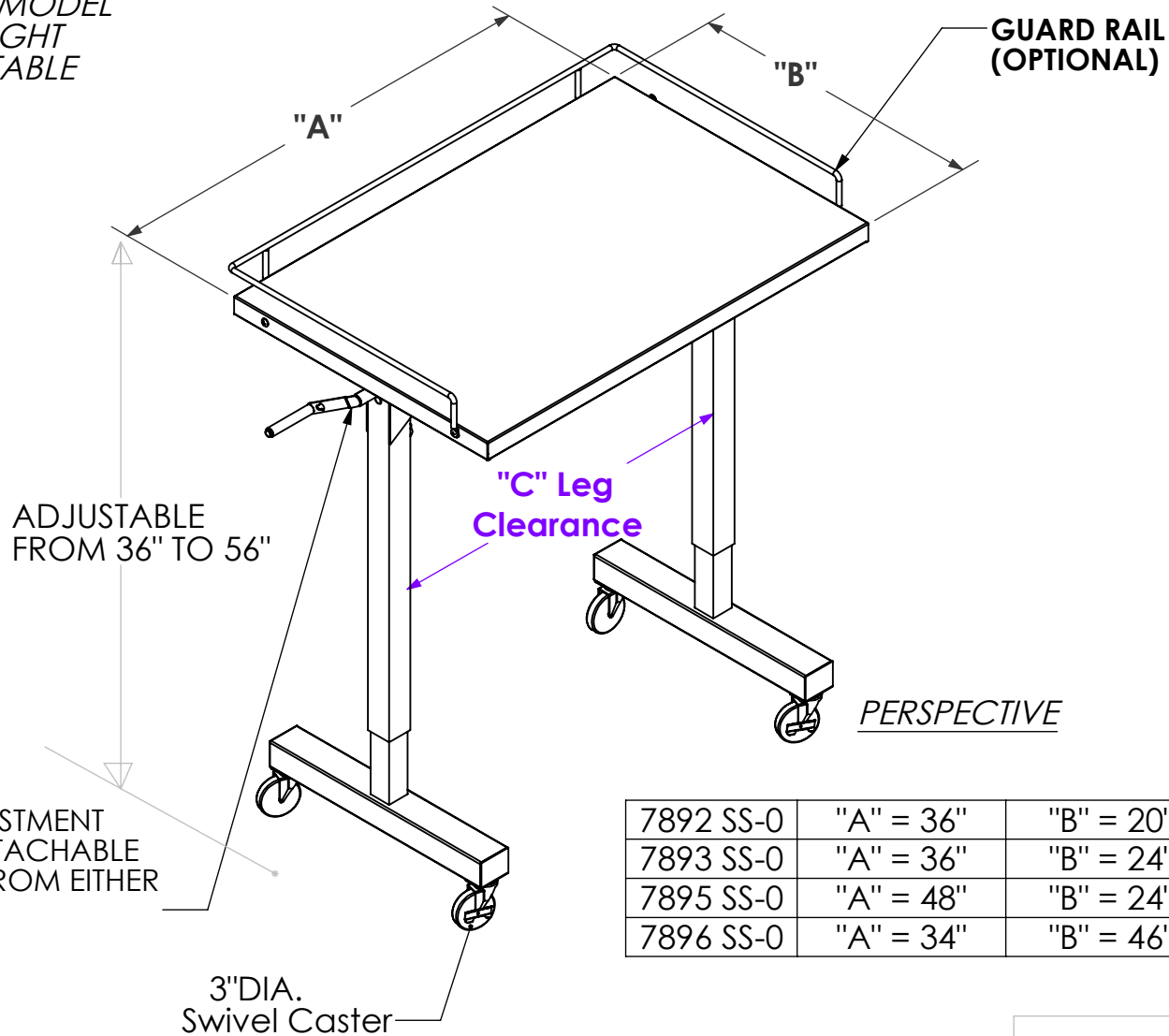

TABLE HEIGHT ADJUSTMENT BY MEANS OF A DETACHABLE HANDLE-ADJUSTS FROM EITHER END OF TABLE.

7892 SS-0	"A" = 36"	"B" = 20"	"C" = 28.625"
7893 SS-0	"A" = 36"	"B" = 24"	"C" = 28.625"
7895 SS-0	"A" = 48"	"B" = 24"	"C" = 40.625"
7896 SS-0	"A" = 34"	"B" = 46"	"C" = 26.625"

PO#: _____ DATE: _____

APPROVAL: _____

TITLE: _____



PROPRIETARY AND CONFIDENTIAL
THE INFORMATION CONTAINED IN THIS DRAWING IS THE SOLE PROPERTY OF BLICKMAN HEALTH INDUSTRIES. ANY REPRODUCTION IN PART OR AS A WHOLE WITHOUT THE WRITTEN PERMISSION OF BLICKMAN HEALTH INDUSTRIES IS PROHIBITED.

UNLESS OTHERWISE SPECIFIED:
DIMENSIONS ARE IN INCHES
BEND RADIUS = MTL. THK.
TOLERANCES:
FRACTION: $\pm 1/8"$
DECIMAL: $\pm .125"$

	NAME	DATE
DRAWN	M.J	06/05/2008
ENG APPR.		
MATERIAL	N/A	
FINISH	N/A	
APPRX WEIGHT	= 81.279 lbs	
DO NOT SCALE DRAWING		

BLICKMAN, INC. CLIFTON, N.J.		
TITLE: GEORGETOWN MODEL		
SIZE A	DWG. NO. INSTRUMENT TABLE	REV EA
SCALE: 1:12		SHEET 1 OF 1