



OPERATION & CARE

MANUAL FOR

P-2010

P-2020

P-2030

P-2040

P-2050

P-2055

BLANKET

WARMING

CABINETS

BLANKET WARMING CABINET

TRANSPORT AND STORAGE

Transport and Storage Environmental Conditions (not to exceed 15 days)

- Ambient temperature range of -40° to +159°F (-40° to +70°C)
- Relative humidity range of 10% to 100%, including condensation
- Atmospheric pressure range of 50KPa to 106KPa

UNPACKING AND SET-UP

DELIVERY

The Pedigo Warming Cabinet has been thoroughly tested and inspected to insure only the highest quality unit is provided. Upon receipt, check for any possible shipping damage and report it at once to the delivering carrier. **See *Transportation Damage and Claims section located in this manual.***

This appliance, complete with unattached items and accessories, may have been delivered in one or more packages. Check to ensure that all standard items and options have been received with each model as ordered.

Save all the information and instructions packed with the appliance. Complete and return the warranty card to the factory as soon as possible to assure prompt service in the event of a warranty parts and labor claim.

This manual must be read and understood by all people using or installing the equipment model. Contact the Pedigo service department if you have any questions concerning installation, operation, or maintenance.

NOTE: All claims for warranty must include the full model number and serial number of the unit.

UNPACKING

1. Carefully remove the appliance from the carton or crate.

NOTE: Do not discard the carton and other packaging material until you have inspected the unit for hidden damage and tested it for proper operation.

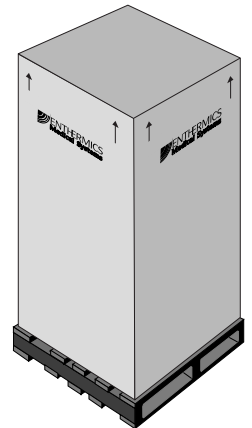

2. Read all instructions in this manual carefully before initiating the installation of this appliance.

DO NOT DISCARD THIS MANUAL. This manual is considered to be part of the appliance and is to be provided to the owner or manager of the business or to the person responsible for training operators. ***Additional manuals are available from the Pedigo service department.***

3. Remove all protective plastic film, packaging materials, and accessories from the appliance before connecting electrical power.

SAFETY PROCEDURES AND PRECAUTIONS

Knowledge of proper procedures is essential to the safe operation of electrically and/or gas energized equipment. In accordance with generally accepted product safety labeling guidelines for potential hazards, the following signal words and symbols may be used throughout this manual.

DANGER Used to indicate the presence of a hazard that **will** cause severe personal injury, death, or substantial property damage if the warning included with this symbol is ignored.

WARNING Used to indicate the presence of a hazard that **can** cause personal injury, possible death, or major property damage if the warning included with this symbol is ignored.

CAUTION Used to indicate the presence of a hazard that can or will cause minor or moderate personal injury or property damage if the warning included with this symbol is ignored.

CAUTION Used to indicate the presence of a hazard that can or will cause minor personal injury, property damage, or a potential unsafe practice if the warning included with this symbol is ignored.

NOTE: Used to notify personnel of installation, operation, or maintenance information that is important but not hazard related.

1. Pedigo blanket warmers are intended for warming cotton blankets **ONLY**. No other use for this device is authorized or recommended.

Pedigo fluid warmers are **ONLY** intended for warming medical solutions for irrigation and injection. The **IRRIGATION MODE** should be selected for warming irrigation fluids, and the **INJECTION MODE** should be selected for warming injection fluids. Please refer to the labeling of the manufacturer of the products to be warmed regarding the recommended temperature and the duration of warming. No other use for this device is authorized or recommended.

2. This device is intended for use in commercial establishments where all operators are familiar with the purpose, limitations, and associated hazards of this device. Operating instructions and warnings must be read and understood by all operators and users.
3. Any troubleshooting guides, component views, and parts lists included in this manual are for general reference only and are intended for use by qualified technical personnel.
4. This manual should be considered a permanent part of this device. This manual and all supplied instructions, diagrams, schematics, parts lists, notices, and labels must remain with the device if the item is sold or moved to another location.

NOTE



For equipment delivered for use in any location regulated by the following directive:
DO NOT DISPOSE OF ELECTRICAL OR ELECTRONIC EQUIPMENT WITH OTHER MUNICIPAL WASTE.

NOTE

Pedigo warmers should not be left unattended for periods of more than 24 hours. In case of absences longer than 24 hours, disconnect the warmer from its power source.

PREPARATION

Before operating the cabinet, clean both the interior and exterior of the unit with a damp cloth and mild soap solution. Rinse carefully. Wipe with an appropriate disinfectant. Clean and install the blanket support assembly.

Environmental conditions for operation: Maximum room ambient temperature of 89°F (32°C).

ELECTRICAL INFORMATION

The power specifications are located on the unit identification nameplate. This nameplate is permanently attached to the unit and must be located to verify power requirements.



POWER REQUIREMENTS - P-2010

120 V.A.C. — 50/60 Hz, 1 ph
600 Watts, 5.5 Amps
Safety Class I Equipment



NEMA 5-15P
15A - 125V Plug
Hospital Grade



POWER REQUIREMENTS - P-2040

120 V.A.C. — 50/60 Hz, 1 ph
2000 Watts, 16.0 Amps
Safety Class I Equipment



NEMA 5-20P
20A - 125V Plug
Hospital Grade



POWER REQUIREMENTS - P-2020

120 V.A.C. — 50/60 Hz, 1 ph
700 Watts, 6.0 Amps
Safety Class I Equipment



NEMA 5-15P
15A - 125V Plug
Hospital Grade



POWER REQUIREMENTS - P-2050

120 V.A.C. — 50/60 Hz, 1 ph
1600 Watts, 13.0 Amps
Safety Class I Equipment



NEMA 5-20P
20A - 125V Plug
Hospital Grade



POWER REQUIREMENTS - P-2030

120 V.A.C. — 50/60 Hz, 1 ph
1000 Watts, 8.0 Amps
Safety Class I Equipment



NEMA 5-15P
15A - 125V Plug
Hospital Grade



POWER REQUIREMENTS - P-2055

120 V.A.C. — 50/60 Hz, 1 ph
1700 Watts, 14.2 Amps
Safety Class I Equipment



NEMA 5-20P
20A - 125V Plug
Hospital Grade



Grounding reliability can only be achieved when equipment is connected to an equivalent receptacle marked "Hospital Grade."



Medical Equipment classified by Underwriters Laboratories with Respect to Electrical Shock, Fire and Mechanical Hazards only, in Accordance with UL 60601-1 and CAN/CSA C22.2 No. 601.1.



UL File No.
E201645

To prevent an electrical shock hazard between the appliance and other appliances or metal parts in close vicinity, an equalization-bonding stud is provided. An equalization bonding lead must be connected to this stud and the other appliances / metal parts to provide sufficient protection against potential difference. The terminal is marked with the following symbol.



UL FILE # <input style="width: 80%;" type="text"/>	MADE IN USA
MODEL <input style="width: 80%;" type="text"/>	
WATTS <input style="width: 80%;" type="text"/>	
VOLTS <input style="width: 20%;" type="text"/> 1 PH <input style="width: 20%;" type="text"/> Hz	
SERIAL# <input style="width: 80%;" type="text"/>	

DANGER



AT NO TIME SHOULD THE INTERIOR OR EXTERIOR BE STEAM CLEANED, HOSED DOWN, OR FLOODED WITH WATER OR LIQUID SOLUTION OF ANY KIND. DO NOT USE WATER JET TO CLEAN.



SEVERE DAMAGE OR ELECTRICAL HAZARD COULD RESULT.

WARRANTY BECOMES VOID IF APPLIANCE IS FLOODED



Hazardous
Voltage Present



DANGER



ENSURE POWER SOURCE MATCHES VOLTAGE STAMPED ON APPLIANCE NAMEPLATE.

GENERAL INFORMATION

This warming cabinet is designed to elevate blanket temperatures to a level which will increase patient comfort.

The warming cabinet is constructed with 20 gauge stainless steel exterior casing and door with handle and hinges designed to withstand heavy usage. A door with window allows observation of inventory with the door closed. The cabinet is warmed using the patented Halo Heat® low-heat-density electrothermal cable array. The electrothermal cable is positioned in the floor and two sides of the warming cabinet, providing even heating of the interior chamber. The interior chamber temperature is regulated by an electronic control. The design and operational characteristics of the cabinet eliminate the need for a heat circulating fan.

The electronic control consists of a 4 digit L.E.D. display, ON/OFF key, INCREASE and DECREASE keys, integrated LOCK feature and a series of prompt sequence indicators. The electronic control has an adjustable temperature range of 37° to 94°C (98° to 200°F). A warming shut-off system, separate from the electronic control, prevents overheating.

The TIMER key allows the user to program the control to automatically turn on and turn off once during a 24 hour period at selected times. The electronic control can easily be set to operate in Fahrenheit or Celsius. After a power failure, the cabinet will remember its programming and begin to operate as before. The ON/OFF indicator will blink to indicate a failure occurred; pressing the ON/OFF key once will eliminate this blinking.

P-2010 INFORMATION

The P-2010 warming cabinet is equipped with one (1) white, epoxy-coated blanket support assembly. The cabinet is furnished with four (4) 1-1/4" (31mm) non-skid rubber feet.

P-2020 INFORMATION

The P-2020 warming cabinet is equipped with one (1) white, epoxy-coated blanket support assembly and one (1) center shelf. The cabinet is furnished with one (1) set of 5" (127mm) heavy duty casters, two with locking brake.

P-2030 INFORMATION

The P-2030 warming cabinet is equipped with one (1) white, epoxy-coated blanket support assembly and one (1) center shelf. The cabinet is furnished with one (1) set of 5" (127mm) heavy duty casters, two with locking brake.

P-2040 INFORMATION



Each P-2040 chamber is equipped with one (1) white, epoxy-coated blanket support assembly and one (1) center shelf. The cabinet is furnished with one (1) set of 5" (127mm) heavy duty casters, two with locking brake.



P-2055 INFORMATION

Each P-2055 chamber is equipped with a white epoxy-coated blanket support assembly and two (2) center shelves. The cabinet is furnished with one (1) set of 5" (127mm) heavy duty casters, two with locking brake.

P-2050 INFORMATION

Each P-2050 chamber is equipped with a white epoxy-coated blanket support assembly. The cabinet is furnished with one (1) transport handle on each end of the cabinet, and a full-perimeter rubber bumper assembly with 5" (127mm) heavy duty casters, two with locking brake.

DANGER	
	AT NO TIME SHOULD THE INTERIOR OR EXTERIOR BE STEAM CLEANED, HOSED DOWN, OR FLOODED WITH WATER OR LIQUID SOLUTION OF ANY KIND. DO NOT USE WATER JET TO CLEAN.
	SEVERE DAMAGE OR ELECTRICAL HAZARD COULD RESULT.
	WARRANTY BECOMES VOID IF APPLIANCE IS FLOODED

DANGER	
	DO NOT use this warming cabinet in the presence of flammable anesthetic mixture (with air or with oxygen or nitrous oxide). THIS COULD RISK AN EXPLOSION!
	

P - 2010 DIMENSIONS

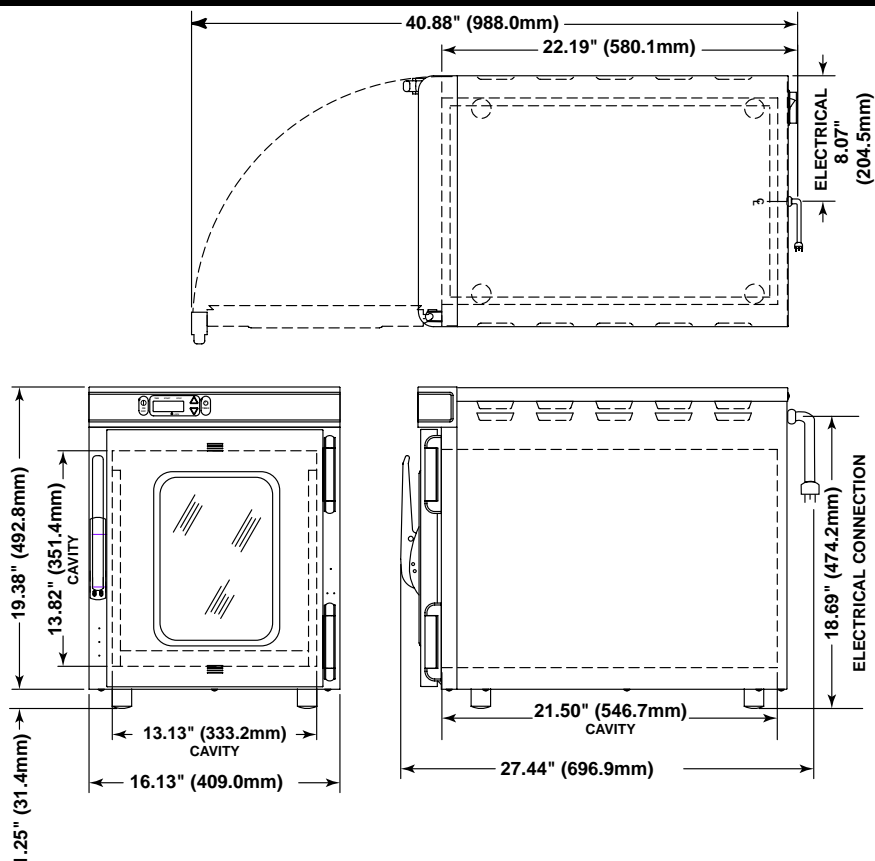

P - 2020 DIMENSIONS

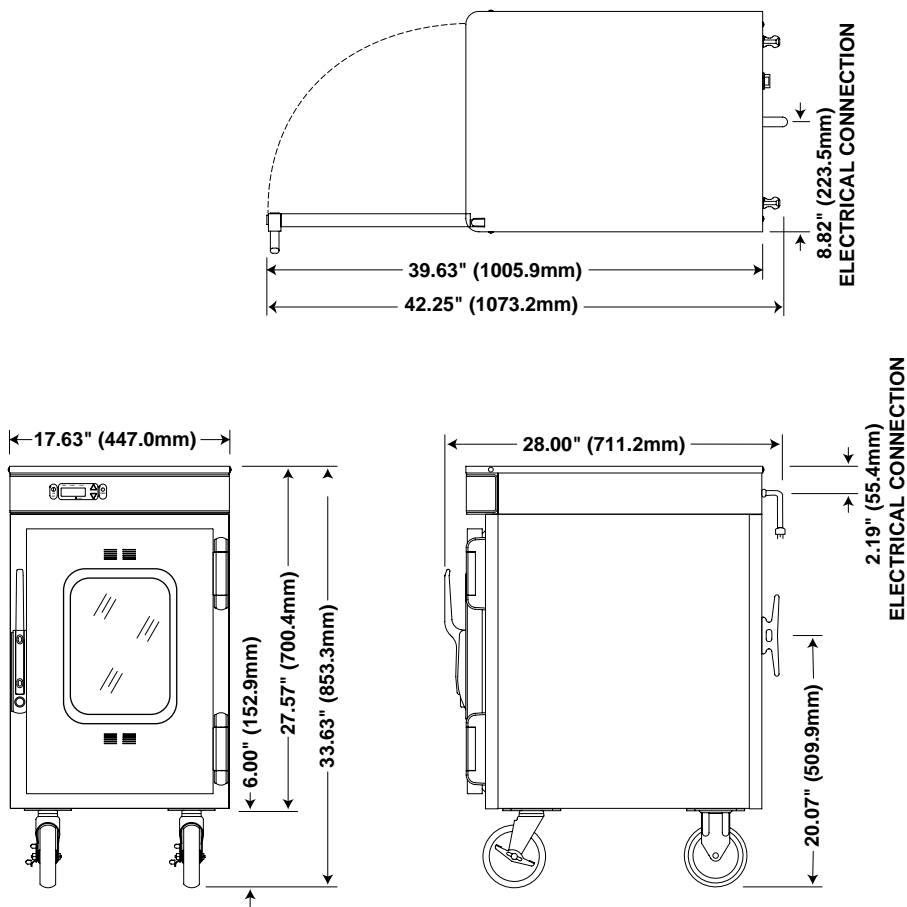

P - 2030 DIMENSIONS

REACH IN

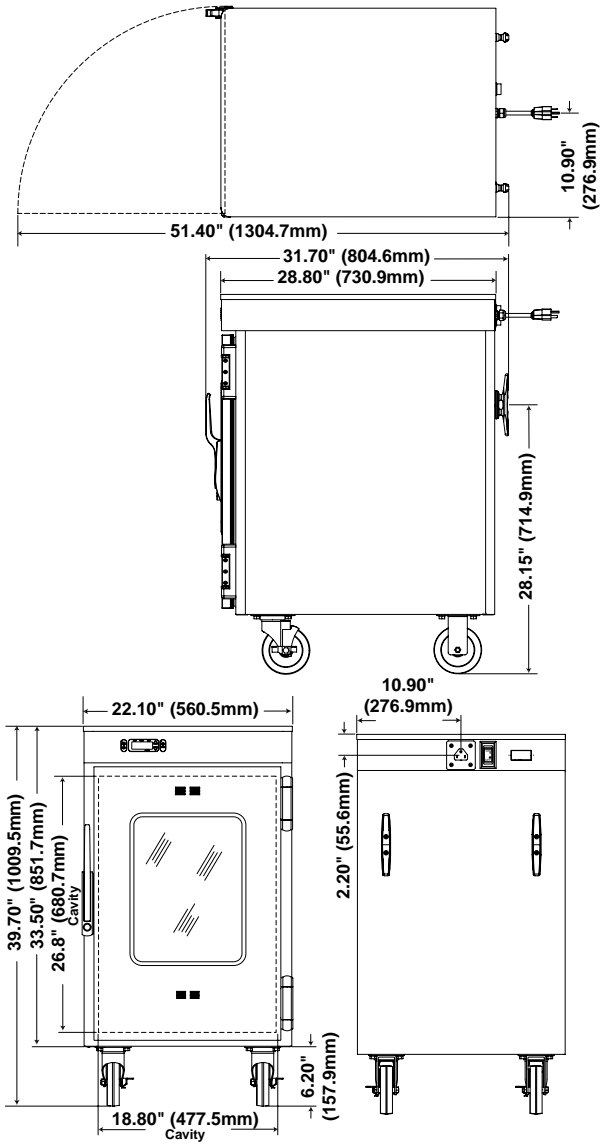

PASS THRU

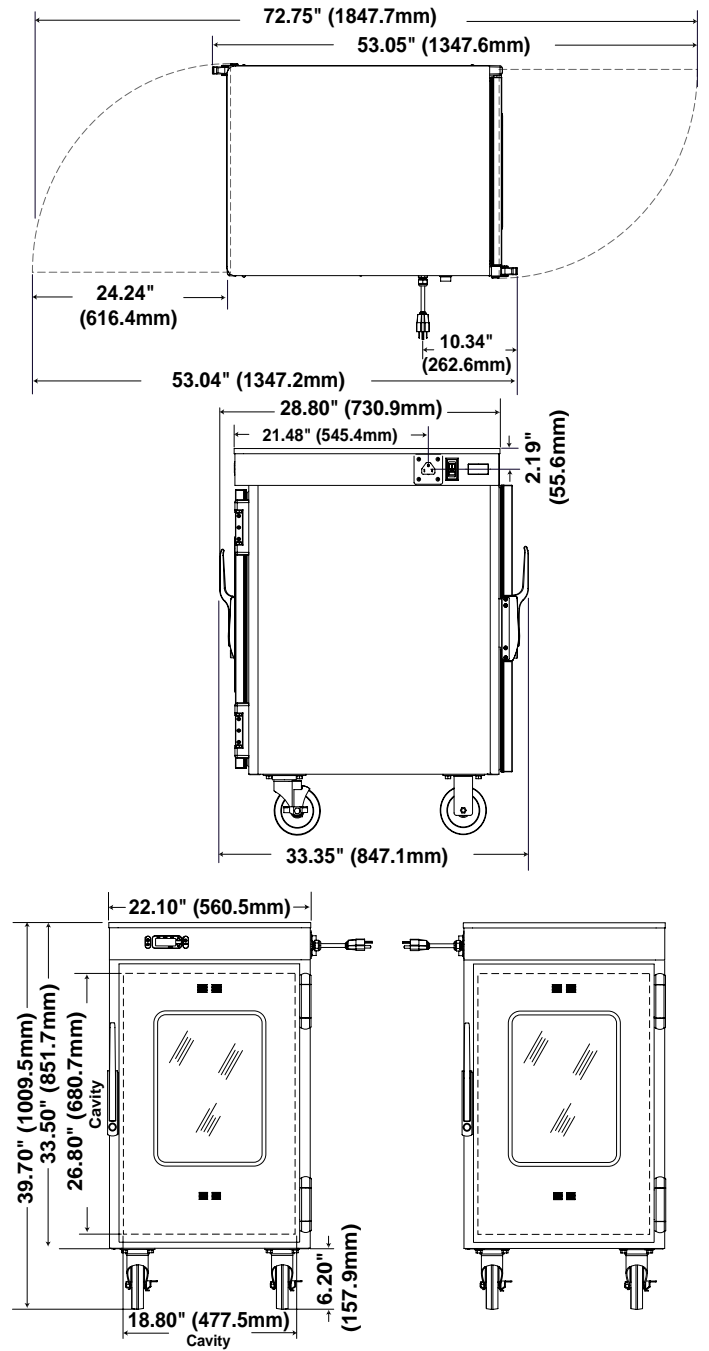

P - 2040 DIMENSIONS

REACH IN

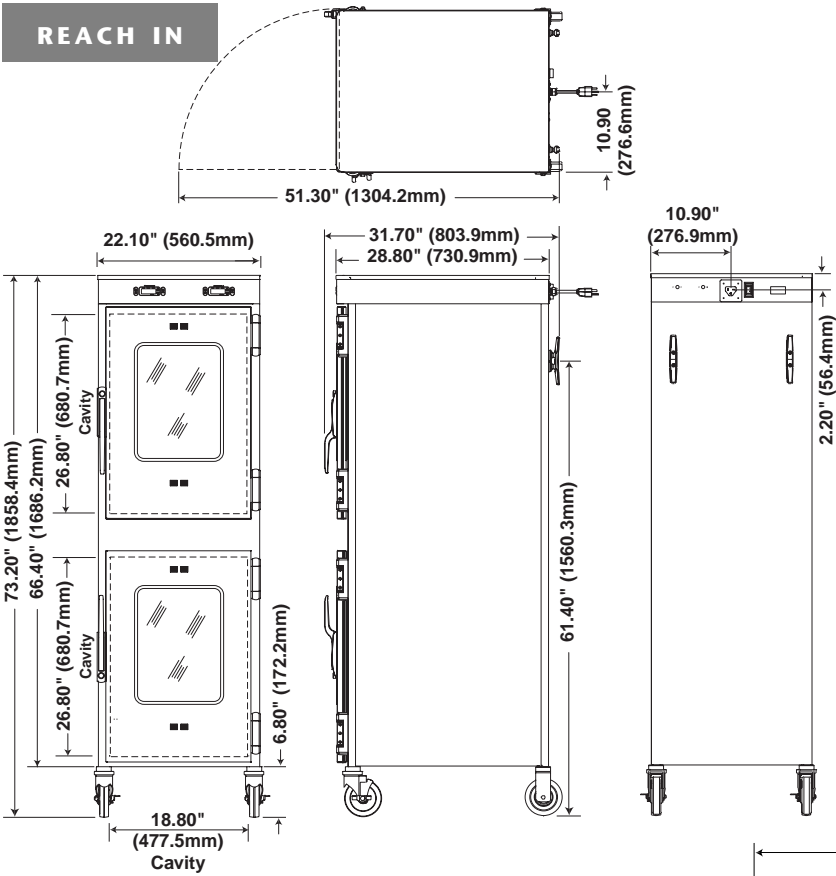

PASS THRU

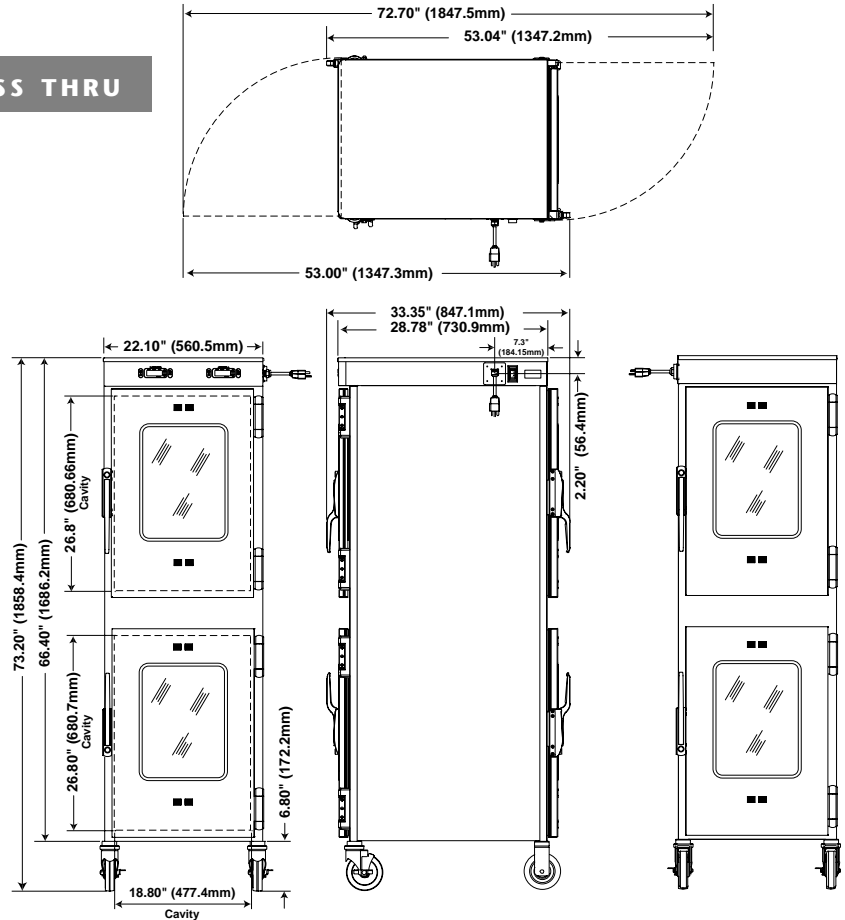

P-2050 DIMENSIONS

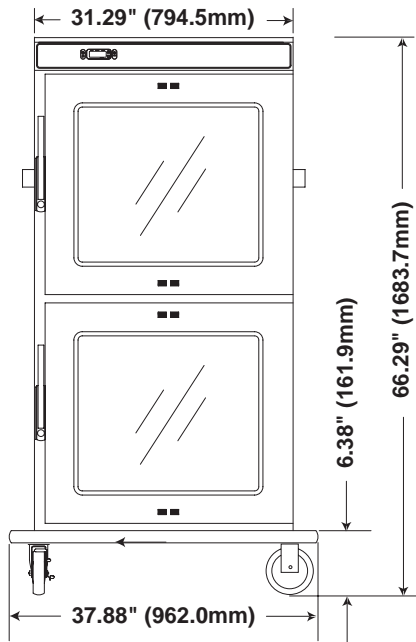
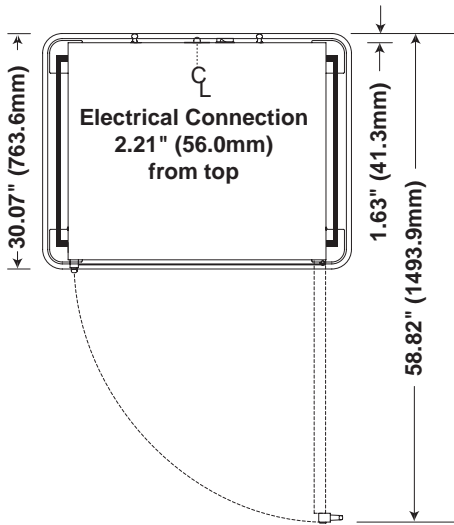

P-2055 DIMENSIONS

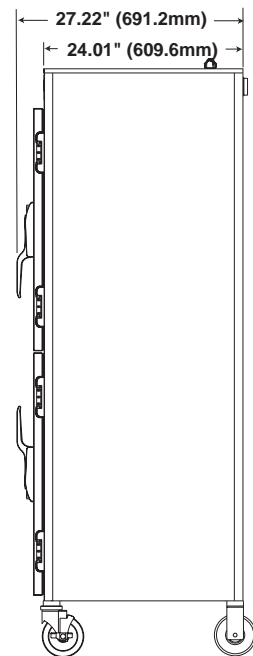
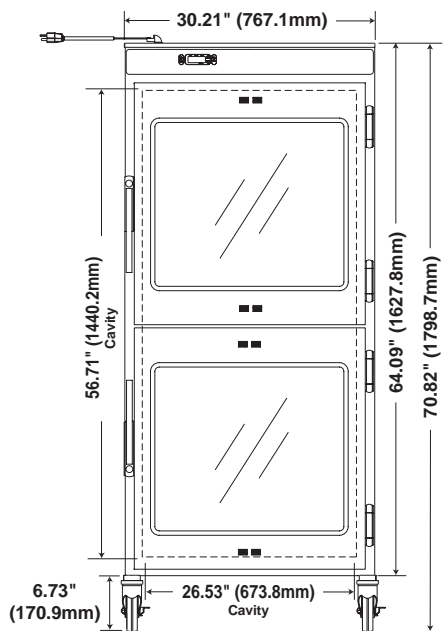
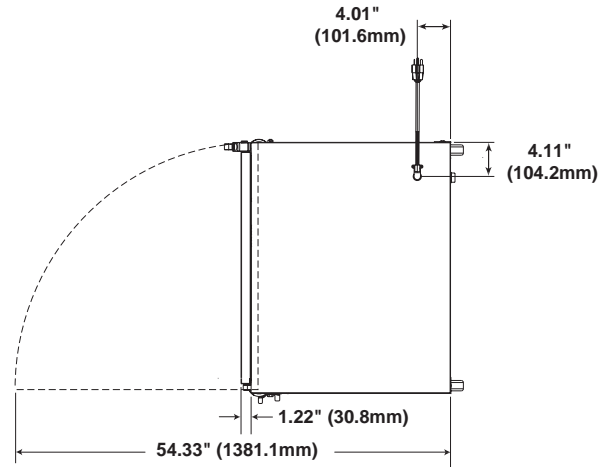

BLANKET CONTROL FEATURES

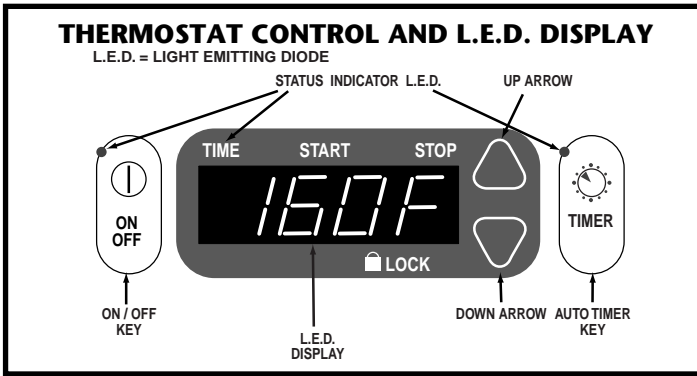

The following refers to features that are available when the control is powered on. When an audible alarm is referenced, the unit will only beep if the audible alarm feature is selected.

CONTROL PANEL KEYS

ON/OFF KEY

Press the ON/OFF key to power on the control. Press and hold the ON/OFF key for 2 seconds to power the control off. The control will beep for one second when turned on or off, and the status indicator light will illuminate according to the power state.

UP ARROW / DOWN ARROW KEYS

Used to increase or decrease the temperature set-point. Additionally used to set the current time, auto-start, and auto-stop times.

TIMER KEY

Blanket warmers have a timer key which is used to program the time of day, as well as the automated start and stop times. To set the start and stop times, press and hold the timer key for 2 seconds. See "Setting the Time" instructions on this page.

L.E.D. DIGITAL DISPLAY

The control has a four-digit L.E.D. display. When the control is activated, the display will show current temperature set-point. When programming the timer, the display will show hour and minutes.

L.E.D. DISPLAY STATUS INDICATORS

TIME

Illuminates while current time of day is displayed when programming the TIMER mode.

START

Illuminates while the start time is displayed when programming the TIMER mode.

STOP

Illuminates while the stop time is displayed when programming the TIMER mode.

LOCK

Illuminates when the lock feature is engaged.

POWER FAIL DETECTION

If the power were to fail for any reason while heating, the warmer will retain its current operating state in memory. When the power is restored, the control will resume operating, but several indicators will alert the operator that such an event has occurred:

- The ON/OFF status indicator will flash.
- Display will indicate '128' (or another number) alternating with the setting. Please see important note below if a number other than '128' is displayed.
- Control will beep until the power failure is acknowledged.

Press the ON/OFF key once to acknowledge that the power has been restored. The ON/OFF status indicator will stop flashing and the "beep" will be silenced. The display will indicate the approximate time period of the outage, then return to the normal display and previously set mode.

NOTE: The display of '128' is a normal Power-On Reset for the control. Any other number displayed may indicate a problem. Make note of the number, and if the unit fails to operate properly, provide that number to service to assist them in troubleshooting the problem.

TEMPERATURE FORMAT SELECTION

While the controller is in the off mode, press and hold the UP ARROW key for 4 seconds to switch between Fahrenheit or Celsius.

AUDIBLE ALARM SELECTION

While the controller is in the off mode, press and hold the DOWN ARROW key for five seconds to switch between audible alarm "ON" and "OFF" modes. When the audible alarm is in the "OFF" mode, an audible alarm will still sound if there is an OVERTEMP error, the door is left open for more than 2 minutes, or in the event of power loss.

SETTING THE DATE AND TIME

NOTES: If you do not wish to use the automated timer feature, then you do not need to set the date and time and this section can be skipped. All times will be displayed in hours and minutes (HH:MM) in a 24-hour format. 1:00pm will display as 13:00. The clock will need to be manually reset for Daylight Saving Time.

While the unit is off, hold the TIMER button for 2 seconds to display the year (2000-2099). Adjust the year up or down using the arrow buttons. Press the TIMER button again to transition to the month and day (MM.DD). Adjust the month and day up or down. Press the TIMER button again to enter the time set mode. The current time of day will show on the display in 24-hour format (HH:MM). Adjust the time up or down. Press the TIMER button again to transition to the Auto-On Time. The

BLANKET CONTROL FEATURES (CONTINUED)

currently programmed Auto-On time will show on the display in 24-hour format. This is the time that the control will automatically turn on when enabled. Adjust to desired time. Press the TIMER button again to transition to the Auto-Off Time. The currently programmed Auto-Off time will show on the display. This is the time the control will automatically turn off when enabled. Adjust to desired time. Press the TIMER button again to enable the Auto-Timer feature. The Time indicator light will turn on. To disable, press and hold the TIMER key for 2 seconds and the indicator light will turn off.

When adjusting the TIMER with the unit on, the year and date will not be adjustable, and will start the programming sequence with the current time of day.

NOTE: When the Auto-On Time and the Auto-Off Times are equal, the unit will recognize the Auto-Off time ONLY and the control will never turn on without user intervention.

USING THE CONTROL LOCK

The warmer control can be locked so that no changes can be made to the temperature set-point or the mode selection. Press the ON/OFF key and the UP arrow key at the same time. The LOCK indicator will illuminate. Attempts to operate the ON/OFF key, or to change the temperature set-point will be unsuccessful. To unlock the warmer control, press the ON/OFF key and the DOWN arrow button at the same time. The control will unlock and the LOCK indicator will extinguish.

BLANKET CHAMBER OPERATIONAL PROCEDURES

1. The appliance should be plugged into a hospital grade, NEMA 5-20P receptacle (120V) or an appropriate receptacle for a 230V appliance.
2. Turn on the power circuit breaker switch, which is located at the back of the appliance. It is a rocker-type switch with international ON (I) and OFF (O) markings.

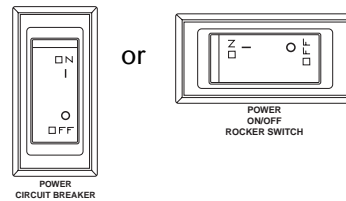

3. **ACTIVATE CONTROL BY PRESSING THE ON/OFF KEY ON CONTROL PANEL ONCE.**
The ON/OFF indicator will illuminate and remain lit until the unit is turned off. The digital L.E.D. display will indicate last temperature set-point of compartment.
4. **SET DESIRED TEMPERATURE.**
To set the blanket warming temperature, press and hold the UP or DOWN ARROW keys to change the value shown in the display. The temperature set-point range is 98 - 200°F (37 - 93°C).

5. **LOAD THE CHAMBER WITH 100% COTTON BLANKETS. DO NOT WARM SYNTHETIC BLEND FABRICS OR ITEMS CONTAINING PLASTIC, RUBBER OR METAL SNAPS, STUDS, HOOKS, ETC.**
Check that the epoxy-coated blanket support assembly and shelf is in place. This blanket support assembly and shelf **MUST** be used to hold blankets. A full load of blankets will take 2-3 hours to reach optimum temperature. Make certain the cabinet door is securely closed after initial loading and following each blanket removal.

Note: Do not block sensor by overloading cabinet with blankets.

6. **ROTATE LOAD OF BLANKETS DAILY.**
Rotate the blankets at the bottom of the load to the top to ensure equal usage. Failure to rotate blankets can cause blankets to discolor.

Note: Avoid using flammable cabinet cleaning agents, as well as blanket cleaning agents that cause fabric to become brittle over time.

CAUTION
BLANKET SUPPORT ASSEMBLY AND SHELF
MUST BE USED WHEN WARMING BLANKETS.

CAUTION
DO NOT OVERLOAD CABINET.
BLANKETS MUST NOT EXCEED HEIGHT OF
SUPPORT ASSEMBLY. ALLOW 1" GAP BETWEEN
LOWER BLANKETS AND MIDDLE SHELF.



Load blankets only to the top of the blanket support assembly.

CLEANING AND PREVENTIVE MAINTENANCE

PROTECTING STAINLESS STEEL SURFACES



It is important to guard against corrosion in the care of stainless steel surfaces. Harsh, corrosive, or inappropriate chemicals can completely destroy the protective surface layer of stainless steel. Abrasive pads, steel wool, or metal implements will abrade surfaces

causing damage to this protective coating and will eventually result in areas of corrosion. Even water, particularly hard water that contains high to moderate concentrations of chloride, will cause oxidation and pitting that result in rust and corrosion. In addition, many acidic spills left to remain on metal surfaces are contributing factors that will corrode surfaces.

Proper cleaning agents, materials, and methods are vital to maintaining the appearance and life of this appliance. Spilled items should be removed and the area wiped as soon as possible but at the very least, a minimum of once a day. Always thoroughly rinse surfaces after using a cleaning agent and wipe standing water as quickly as possible after rinsing.

ANNUAL PREVENTATIVE MAINTENANCE

1. Ensure that the correct Operation and Care manual is available to all users.
2. Ensure that all users have been properly trained in unit's operation.
3. Do not exceed the unit's capacity.
4. Inspect condition of plug and cord. Replace if damaged.
5. Clean dust from outer vents surrounding the unit and around top of bonnet.
6. Check door gasket. Are there any tears? Is the gasket worn or loose? Make sure seal is tight to unit body. Replace gasket if integrity is compromised.
7. Check air temperature sensor mounted on the interior of chamber. Is the metal guard in place? Are the wires in good condition?
8. Check the blanket support assembly and shelf (if applicable) Is the assembly in place? Are any pieces missing?

CLEANING AGENTS

Use non-abrasive cleaning products designed for use on stainless steel surfaces. Cleaning agents must be chloride-free compounds and must not contain quaternary salts. Never use hydrochloric acid (muriatic acid) on stainless steel surfaces. Always use the proper cleaning agent at the manufacturer's recommended strength. Contact your local cleaning supplier for product recommendations.

CLEANING MATERIALS

The cleaning function can usually be accomplished with the proper cleaning agent and a soft, clean cloth. When more aggressive methods must be employed, use a non-abrasive scouring pad on difficult areas and make certain to scrub with the visible grain of surface metal to avoid surface scratches. Never use wire brushes, metal scouring pads, or scrapers to remove residue.



9. Check basket and side rail condition (if applicable). Do baskets move smoothly and freely?
 10. check caster or leg condition. Ensure mounting bolts and assembly is secure.
 11. Check control panel overlay condition. Are there any tears or excessive wear on the graphic? Does control work properly when buttons are pushed?
 12. Check that all control LEDs light up as applicable.
 13. Is the Set Temperature comparable to the Actual temperature displayed? If not, control needs calibration. Call Service.
- Contact Service for immediate repair if any of the above problems exist.

CAUTION	
	TO PROTECT STAINLESS STEEL SURFACES, COMPLETELY AVOID THE USE OF ABRASIVE CLEANING COMPOUNDS, CHLORIDE BASED CLEANERS, OR CLEANERS CONTAINING QUATERNARY SALTS. NEVER USE HYDROCHLORIC ACID (MURIATIC ACID) ON STAINLESS STEEL. NEVER USE WIRE BRUSHES, METAL SCOURING PADS OR SCRAPERS.

CARE AND CLEANING

The cleanliness and appearance of this equipment will contribute considerably to its operating efficiency. Make certain the cabinet and door gasket are kept free of any debris that may accumulate. Good equipment that is kept clean works better and lasts longer.

CLEAN THE UNIT REGULARLY:

1. Disconnect the cabinet from the power source.
2. Remove all detachable items such as the metal basket and basket rail supports. Clean these items separately.

NOTE: Avoid the use of abrasive cleaning compounds, chloride based cleaners, or cleaners containing quaternary salts. Never use hydrochloric acid (muriatic acid) on stainless steel.

3. Clean the interior metal surfaces of the cabinet with a damp cloth and any mild commercial detergent. Avoid the use of abrasive cleaning compounds. Rinse surfaces by wiping with sponge & clean warm water. Remove excess water with sponge and wipe dry with a clean cloth or air dry. Leave doors open until interior is completely dry.
4. Interior can be wiped with a sanitizing solution after cleaning and rinsing. This solution must be approved for use on stainless steel surfaces. Replace blanket support assembly.
5. To help maintain the protective film coating on polished stainless steel, clean the exterior of the cabinet with a cleaner recommended for stainless steel surfaces. Spray the cleaning agent on a clean cloth and wipe with the grain of the stainless steel.
6. Clean the window glass with a standard commercial glass cleaner.
7. Wipe control panel, door vents, door handles, and door gaskets thoroughly since these areas harbor debris.
8. Wipe door gaskets and control panel dry with a clean, soft cloth.

Always follow appropriate state or local health (hygiene) regulations regarding all applicable cleaning and sanitation requirements.

9. To help maintain the protective film coating on polished stainless steel, clean the exterior of the cabinet with a cleaner recommended for stainless steel surfaces. Spray the cleaning agent on clean cloth a wipe with grain of the stainless steel.



NO SCRAPERS



NO STEEL PADS

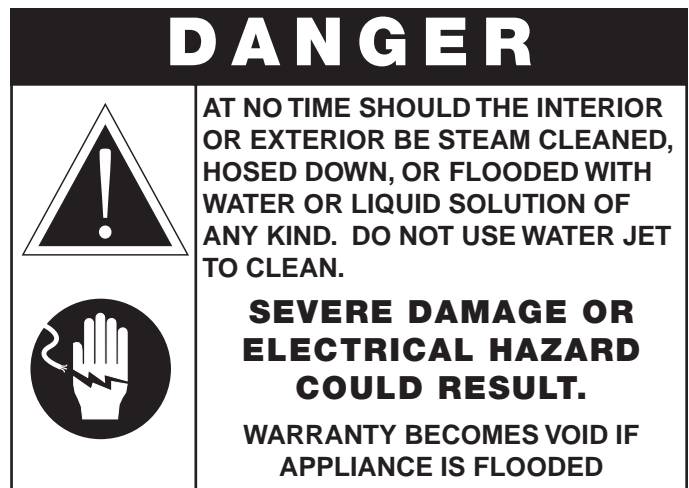
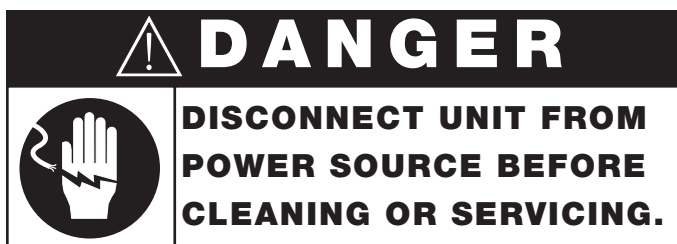

(Listed as Ordinary Equipment.)



If your unit is not operating properly, check the following before calling your authorized service agent. Check the power applied to the unit. Is the plug in outlet? Is the power circuit breaker switch in rear of unit OK? Has the high limit manual reset tripped? If so, reset. (See “Manual Reset Instructions” below.)

If temperature calibration adjustment is required, call Entermics Service for proper instruction.

Do not attempt to repair or service beyond this point. Contact manufacturer for nearest authorized service agent. Repairs made by any other service agent without prior authorization by manufacturer will void the warranty on the unit.

This chart is provided for the assistance of qualified technicians only and is not intended for use by untrained or unauthorized service personnel.

TROUBLE SHOOTING GUIDE

ERROR	DESCRIPTION	ACTION REQUIRED
E-10	Sensor Short	<ul style="list-style-type: none"> Detach the sensor from the terminal block. Use an Ohm meter to measure the resistance of the sensor. Check sensor at 32°F (0°C) using a container of ice water. If Ohm reading is 100, replace display. If Ohm reading is ±10, replace sensor. Check wires for integrity. Check for proper and secure connections at the control and terminal block. If necessary, re-secure the faulty connections. If error continues call Service.
E-11	Sensor Open	<ul style="list-style-type: none"> Detach the sensor from the terminal block. Use an Ohm meter to measure the resistance of the sensor. Check sensor at 32°F (0°C) using a container of ice water. If Ohm reading is 100, replace display. If Ohm reading is ±10, replace sensor. Check wires for integrity. Check for proper and secure connections at the control and terminal block. If necessary, re-secure the faulty connections. If error continues call Service.
E-30	Under Temp Error (Blanket warmers only)	<ul style="list-style-type: none"> Blanket chamber temperature has been lower than the set temperature for 90 minutes or longer. Check that door is closed. Verify that the high limit switch located at the rear of the unit has not been tripped. If it has been tripped, reset by pressing in the limit reset button. After resetting, the cause of the high limit trip must be corrected. If the high limit switch will not reset, the high limit switch is defective and must be replaced. This is a safety device and must not be jumped out or removed from the circuit.
E-31	Over Temp	<ul style="list-style-type: none"> Unit may be overloaded. Redistribute inventory. Do not exceed height of basket assembly. Check sensor at 32°F (0°C) using a container of ice water. The sensor reading should be 100 ohms. Relay (solid state) may be defective. Control may have defective temperature circuit. If error continues call Service.
E-60	Real-Time Clock Checksum Error	<ul style="list-style-type: none"> Unit may have been unplugged for an extended period of time. To resolve, turn circuit breaker switch to ON position for 1 minute, then turn circuit breaker switch to the OFF position for 5 seconds, and then back to ON. The error message should no longer appear in the display. In order for the unit to fully recharge, it should remain plugged in and power circuit breaker switch turned ON for at least 24 hours after resetting. Upon resolving an E-60 error, check that the date and time are correct.
E-80	EPROM Data	<ul style="list-style-type: none"> Call Service.
E-81	Calibration Values Out of Expected Range	<ul style="list-style-type: none"> Call Service.
E-82	Calibration Data Error	<ul style="list-style-type: none"> Call Service.
E-99	Hardware Over Temp	<ul style="list-style-type: none"> Inspect connections and condition of high limit bimetal thermostat. If error continues call Service.

NOTE: All error codes must be cleared using the circuit breaker switch or power cord on the rear of the unit.

Manual Reset Instructions: Locate the manual reset button on back of unit. Using a pen, screwdriver or other long, thin implement, firmly push reset button. You will hear an audible click when the button is reset. If reset button trips again while unit is running, contact a qualified service technician.

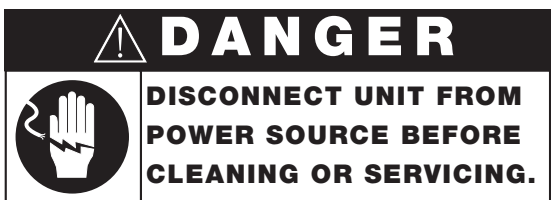

Manual reset button

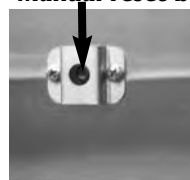

Circuit breaker



Service Views of P-2010

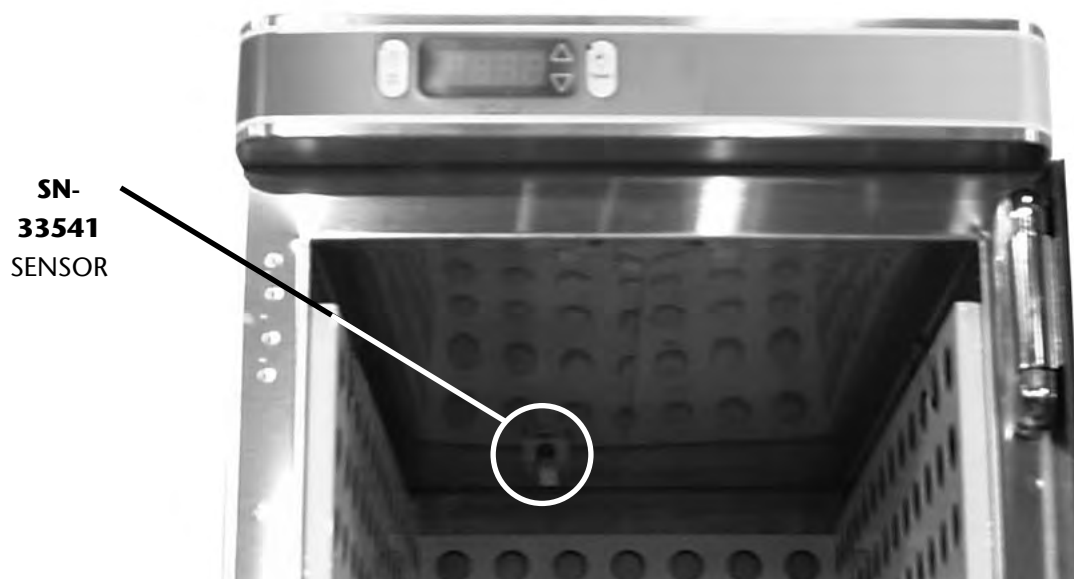
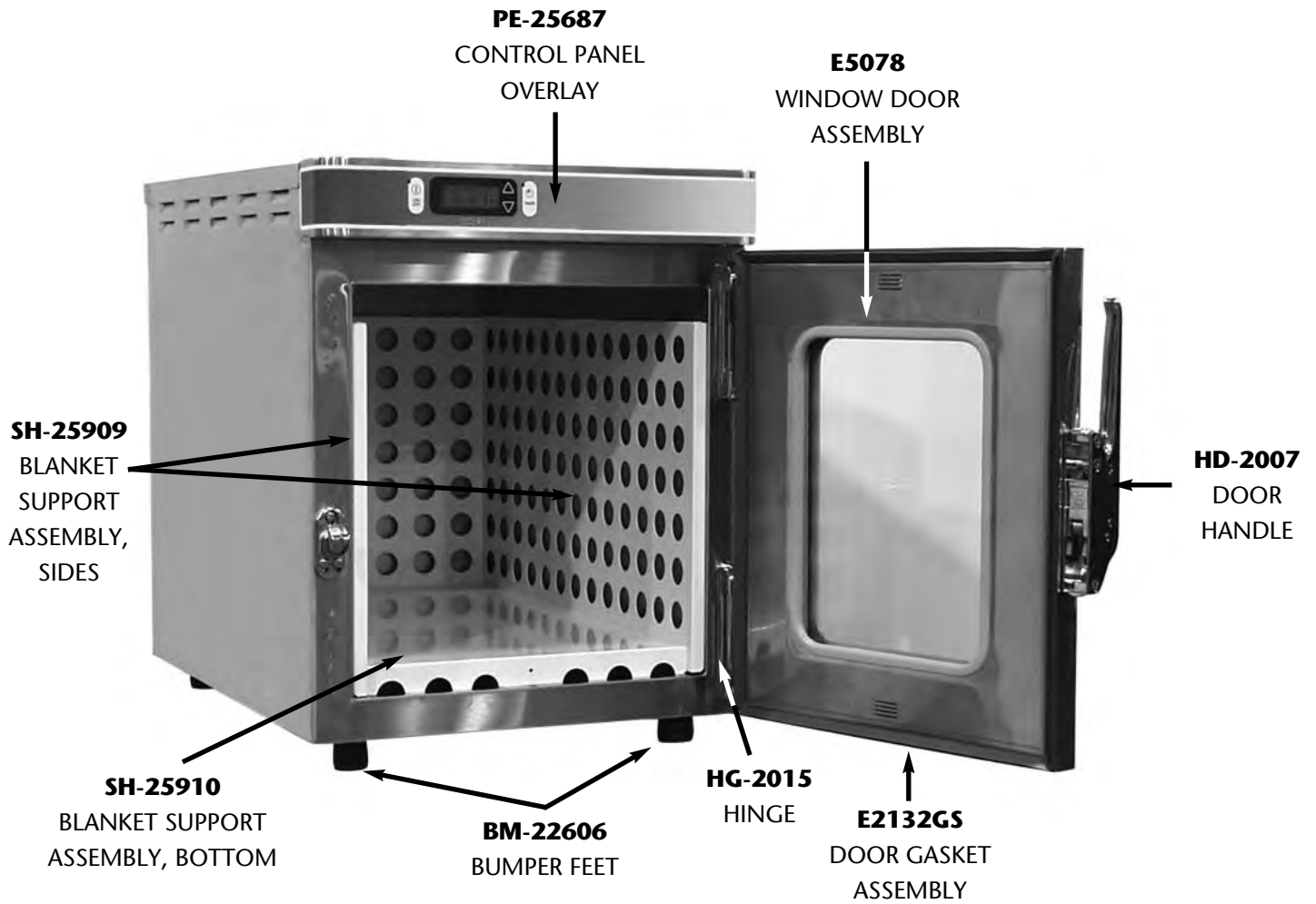

Service Views of P-2010

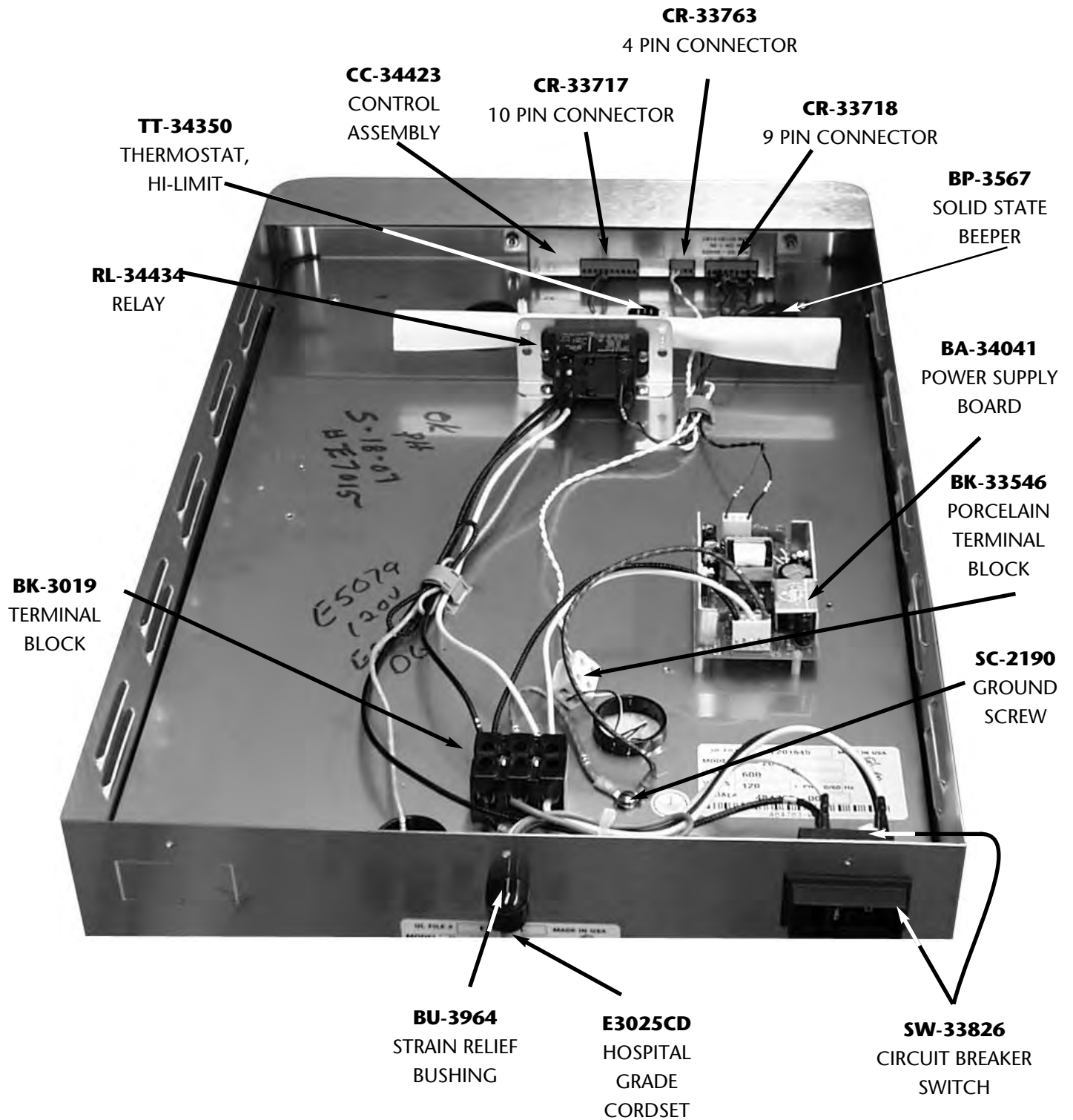

Service Views of P-2020

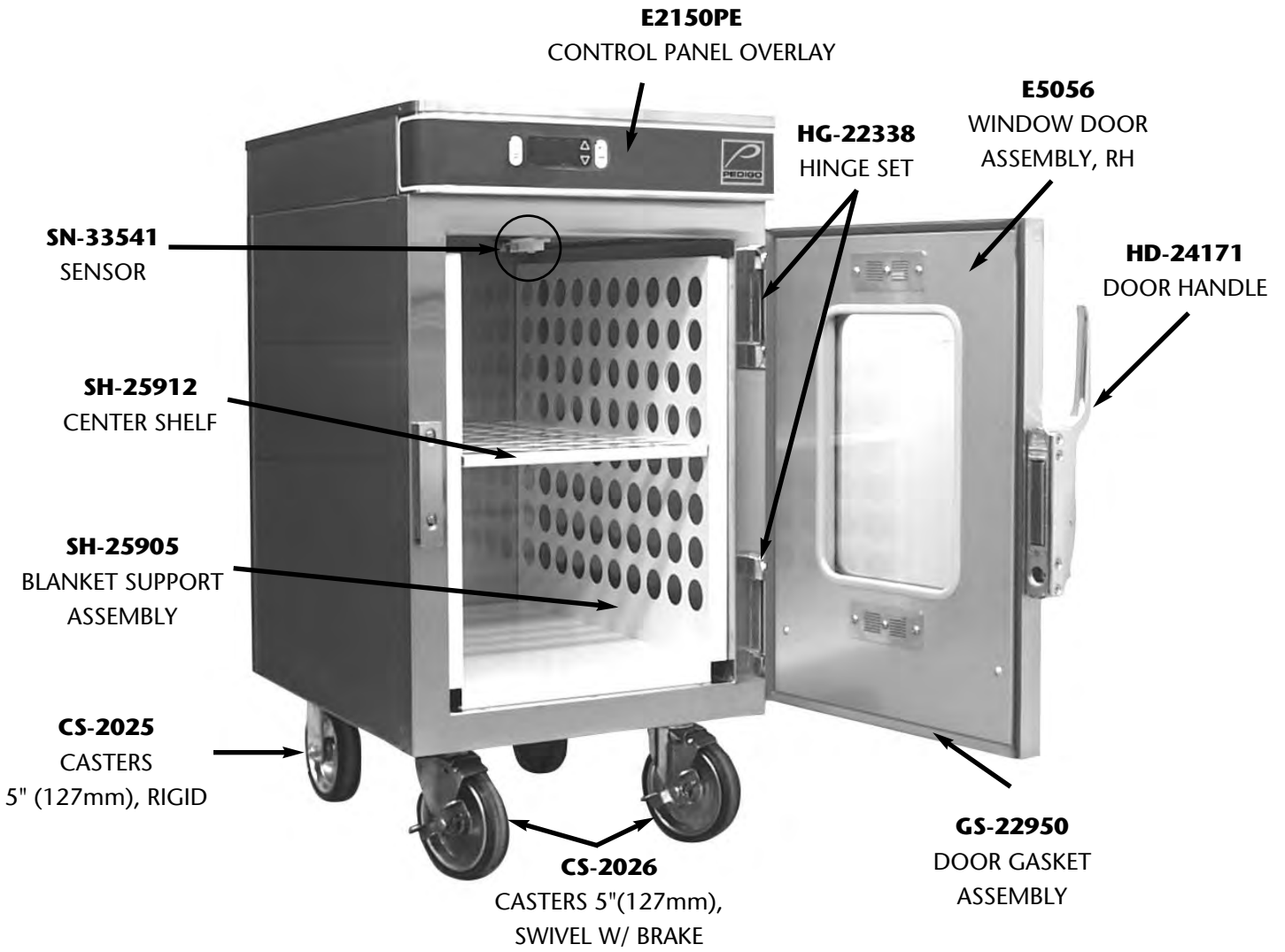

Service Views of P-2020

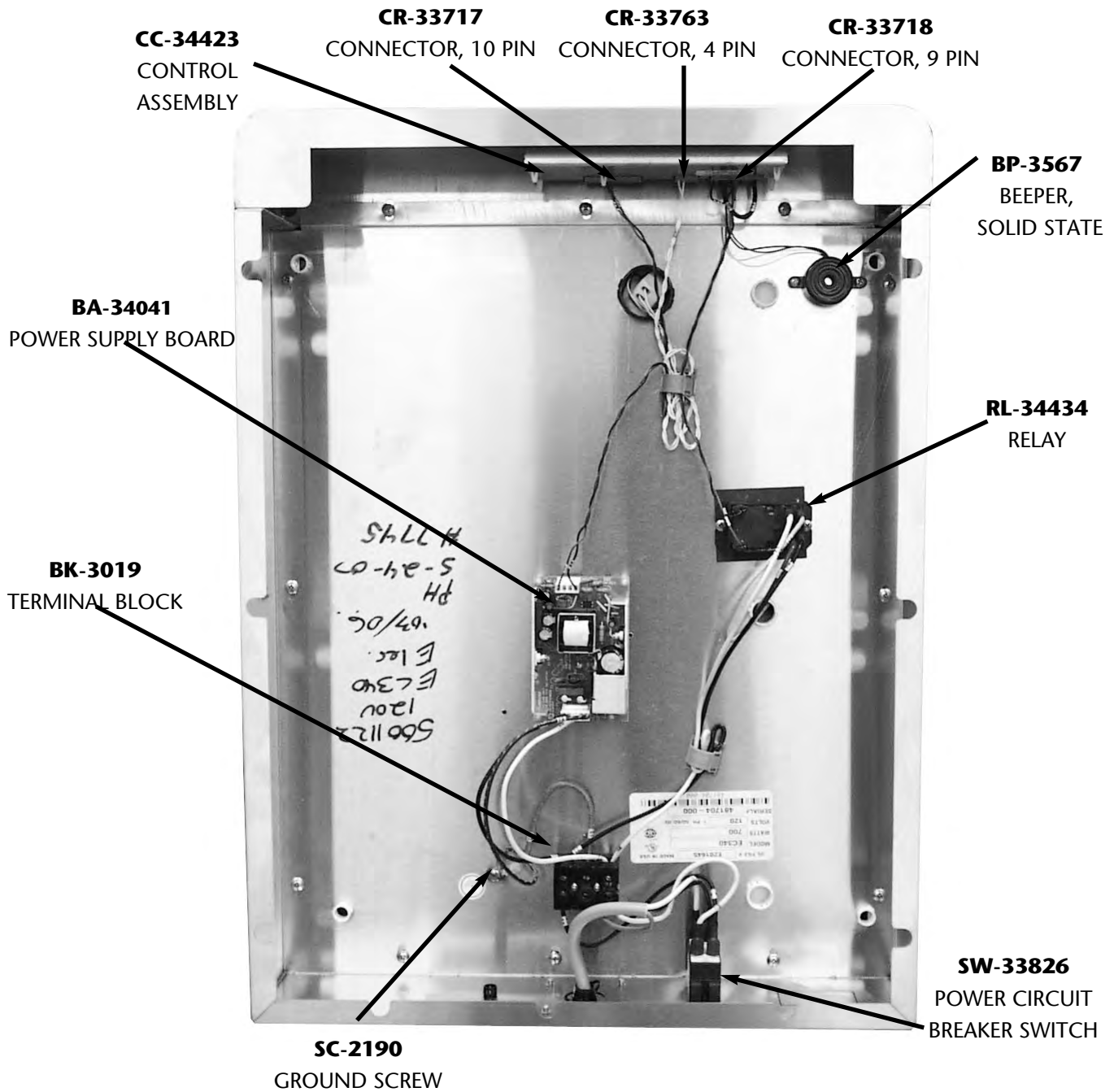

P-2020 Wiring Diagram

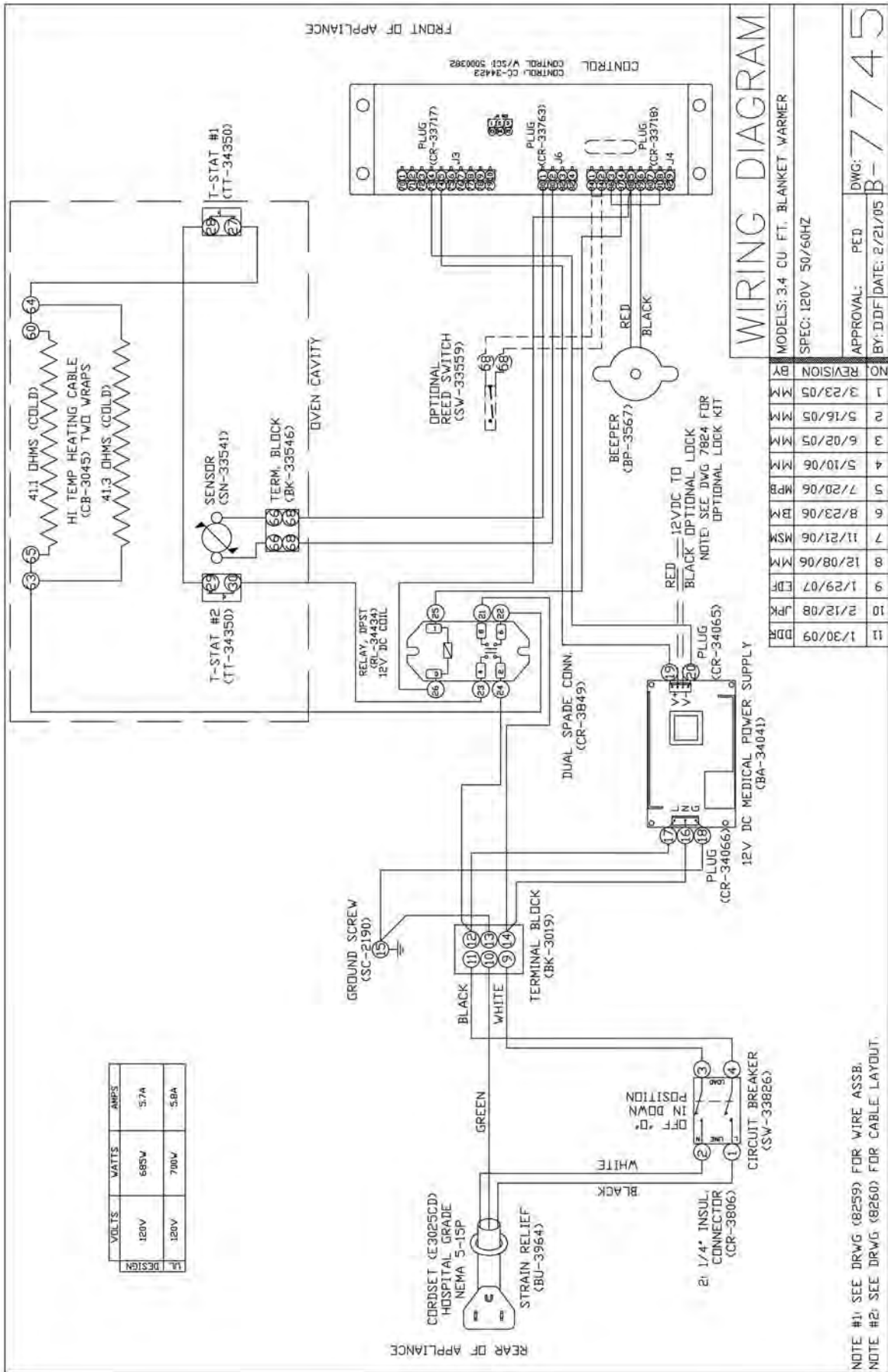

Service Views of P-2030

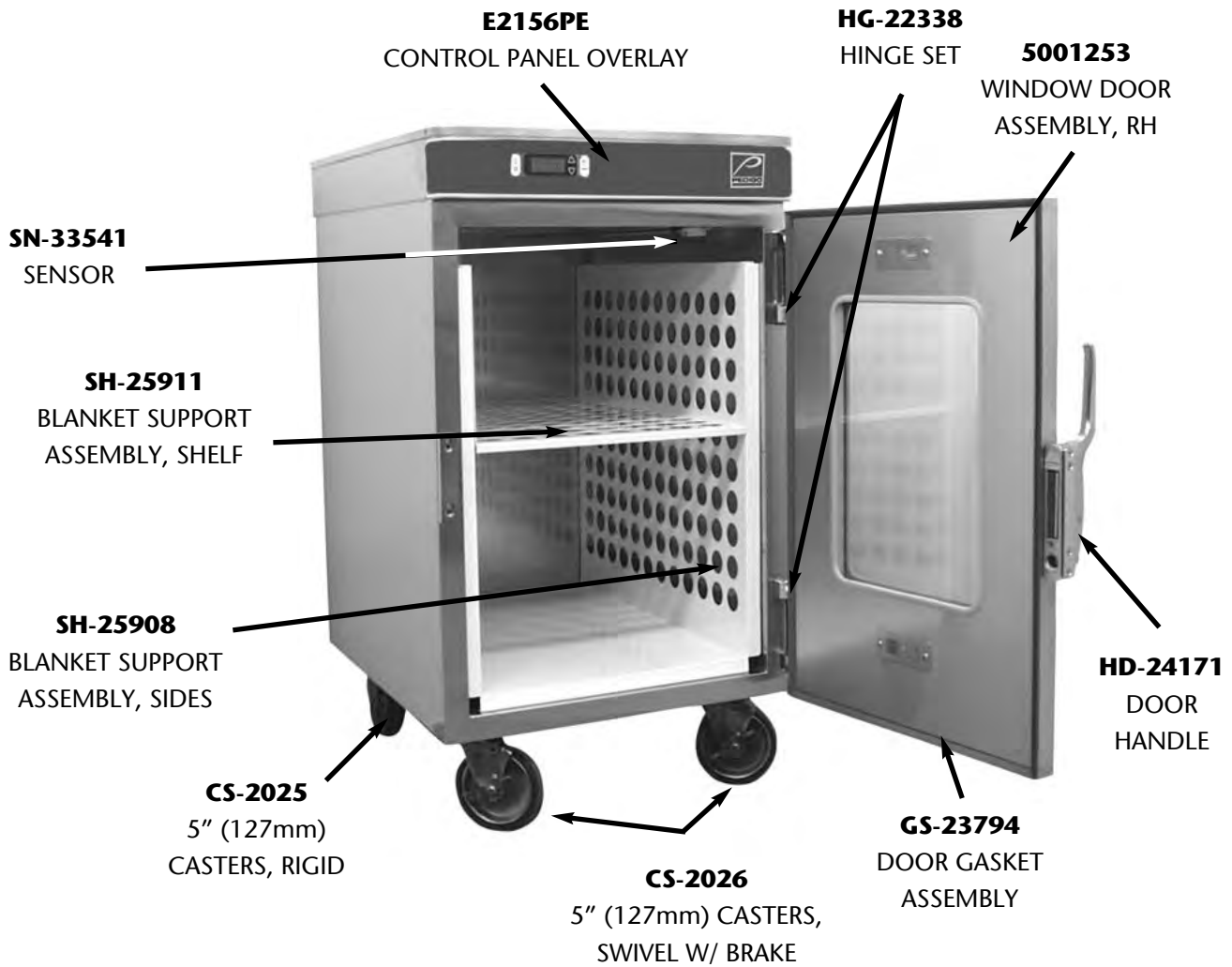

Service Views of P-2030

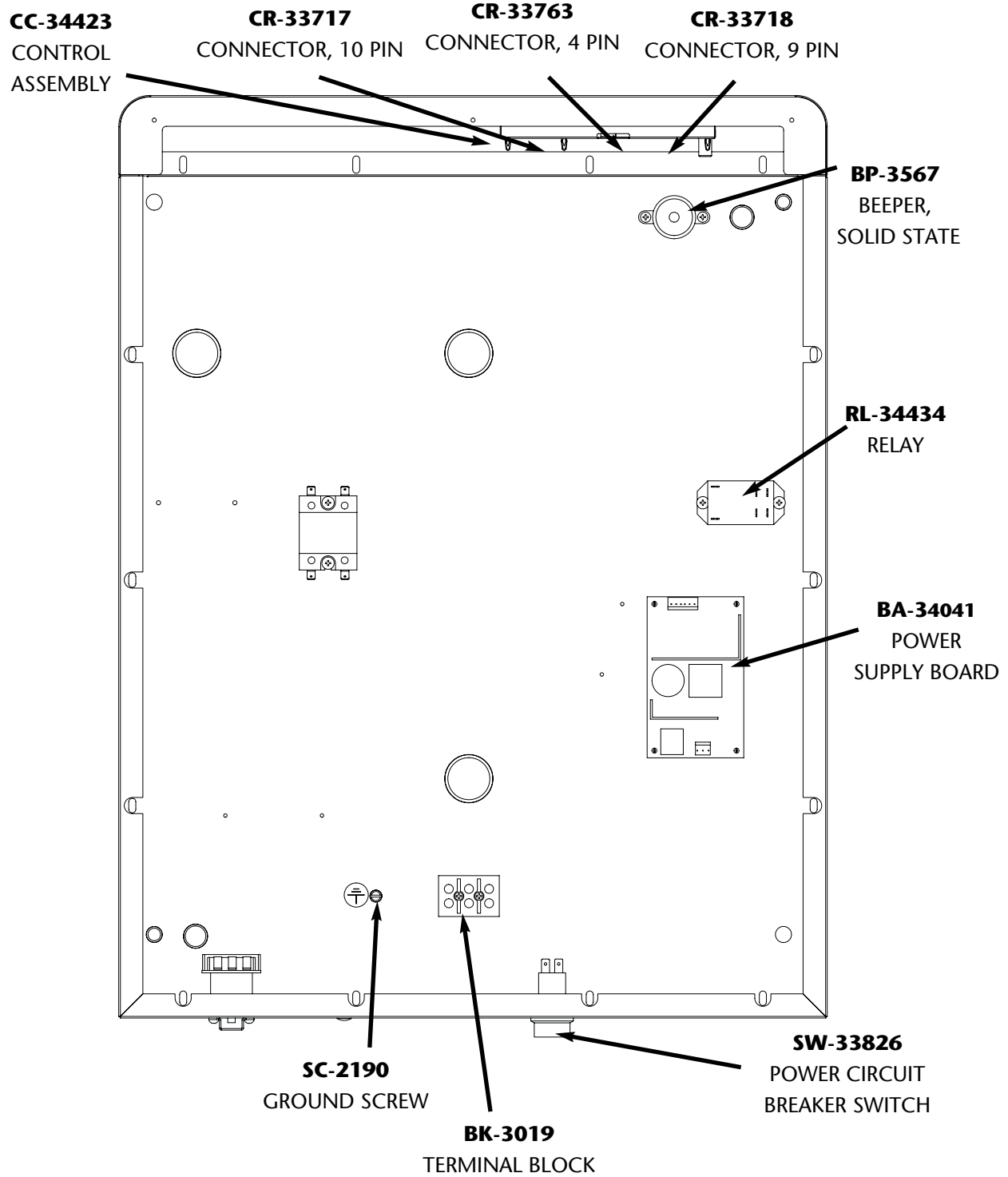

P-2030 Wiring Diagram

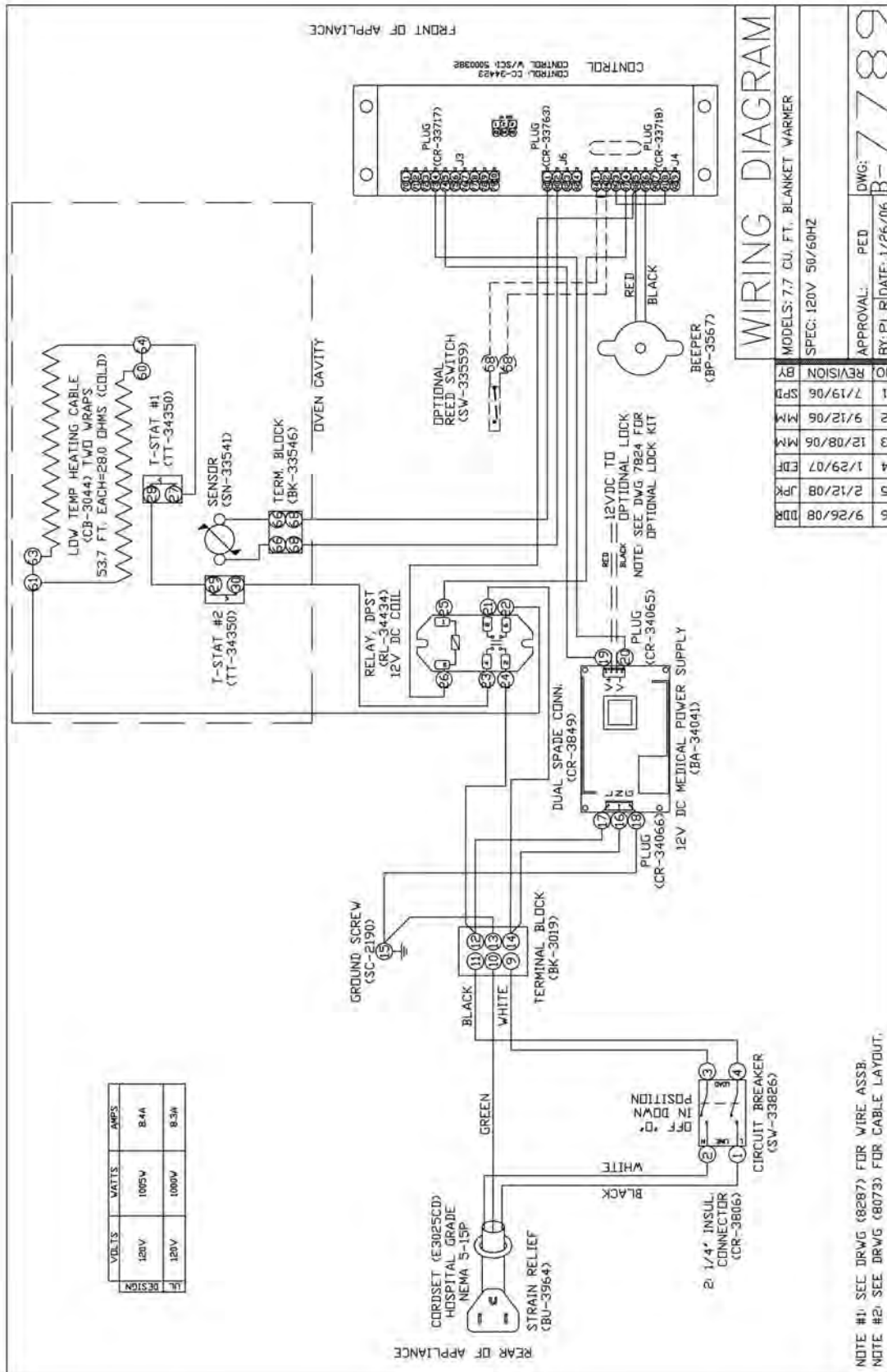

Service Views of P-2040

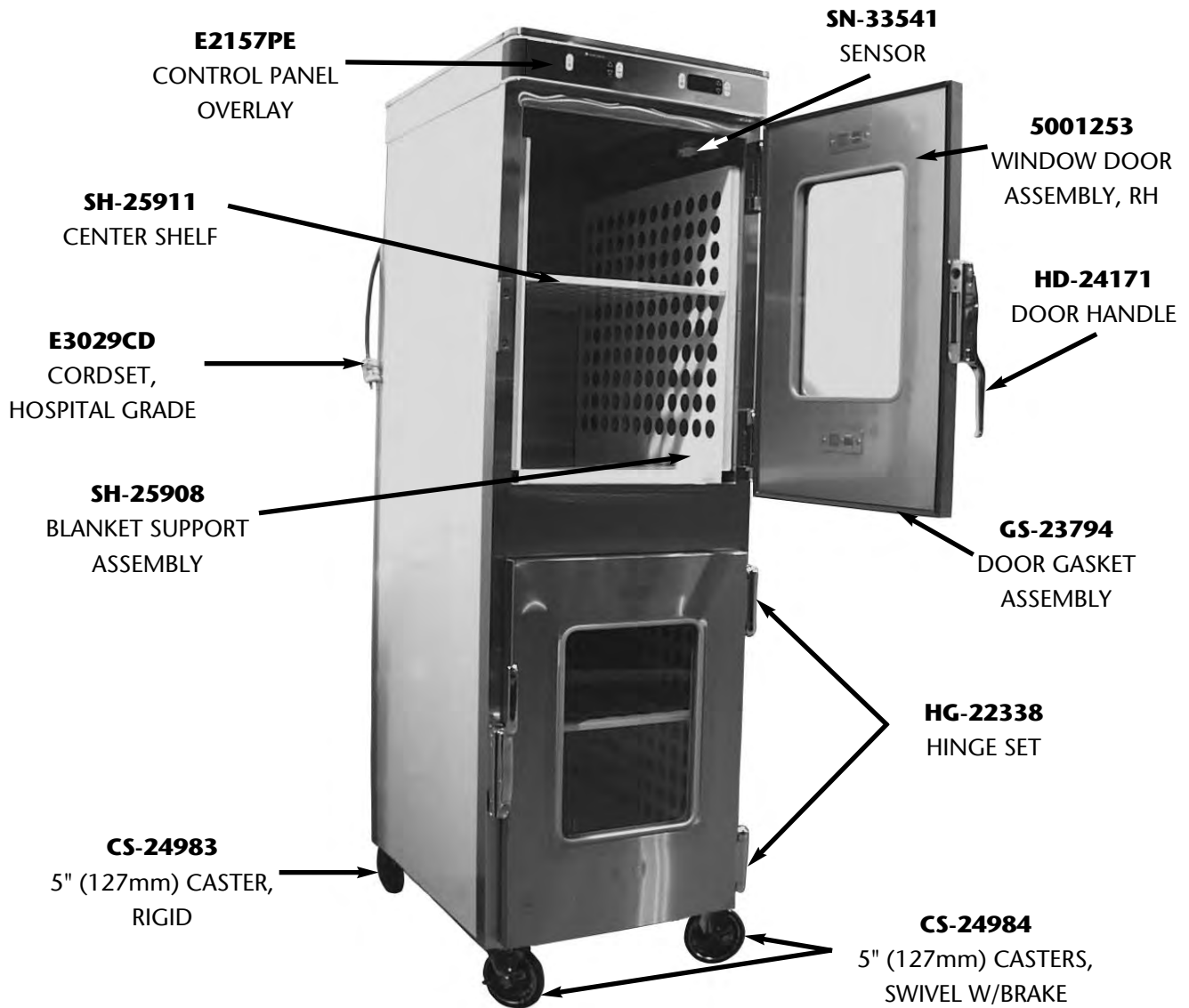

Service Views of P-2040

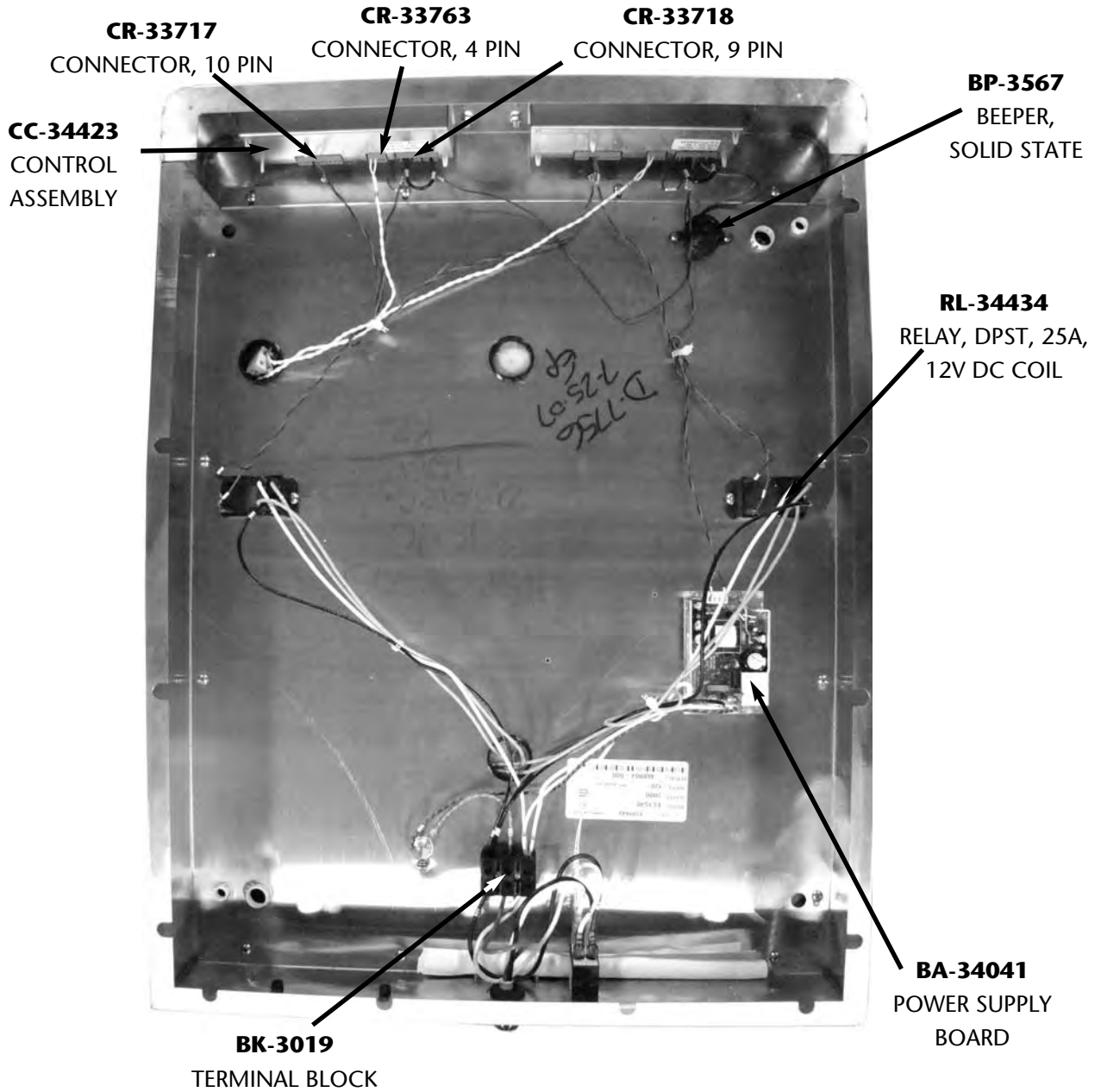

P-2040 Wiring Diagram

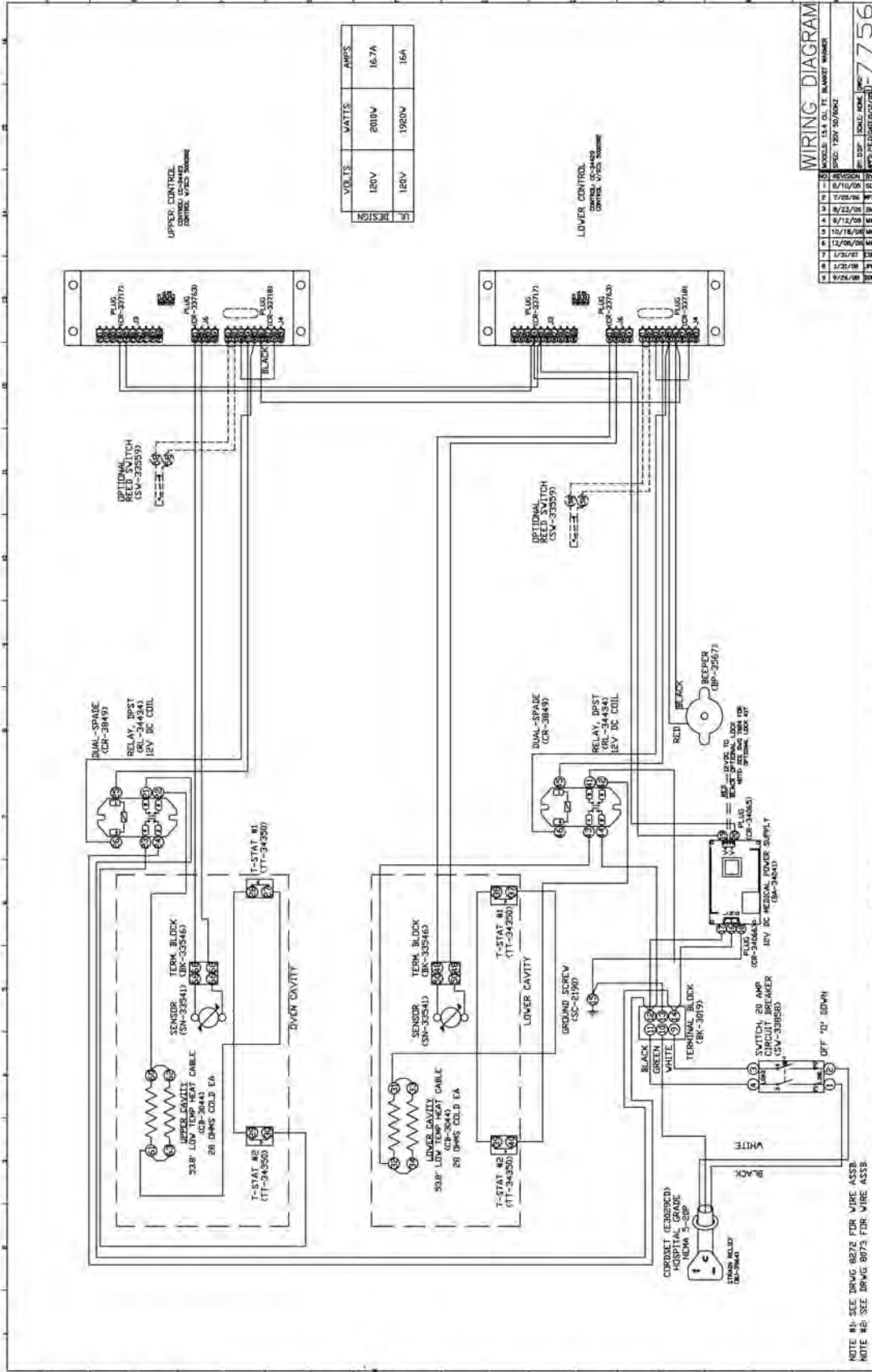

NOTE #1: SEE DRAWG 8073 FOR WIRE ASSG.
 NOTE #2: SEE DRAWG 8073 FOR WIRE ASSG.



Service View of P-2050

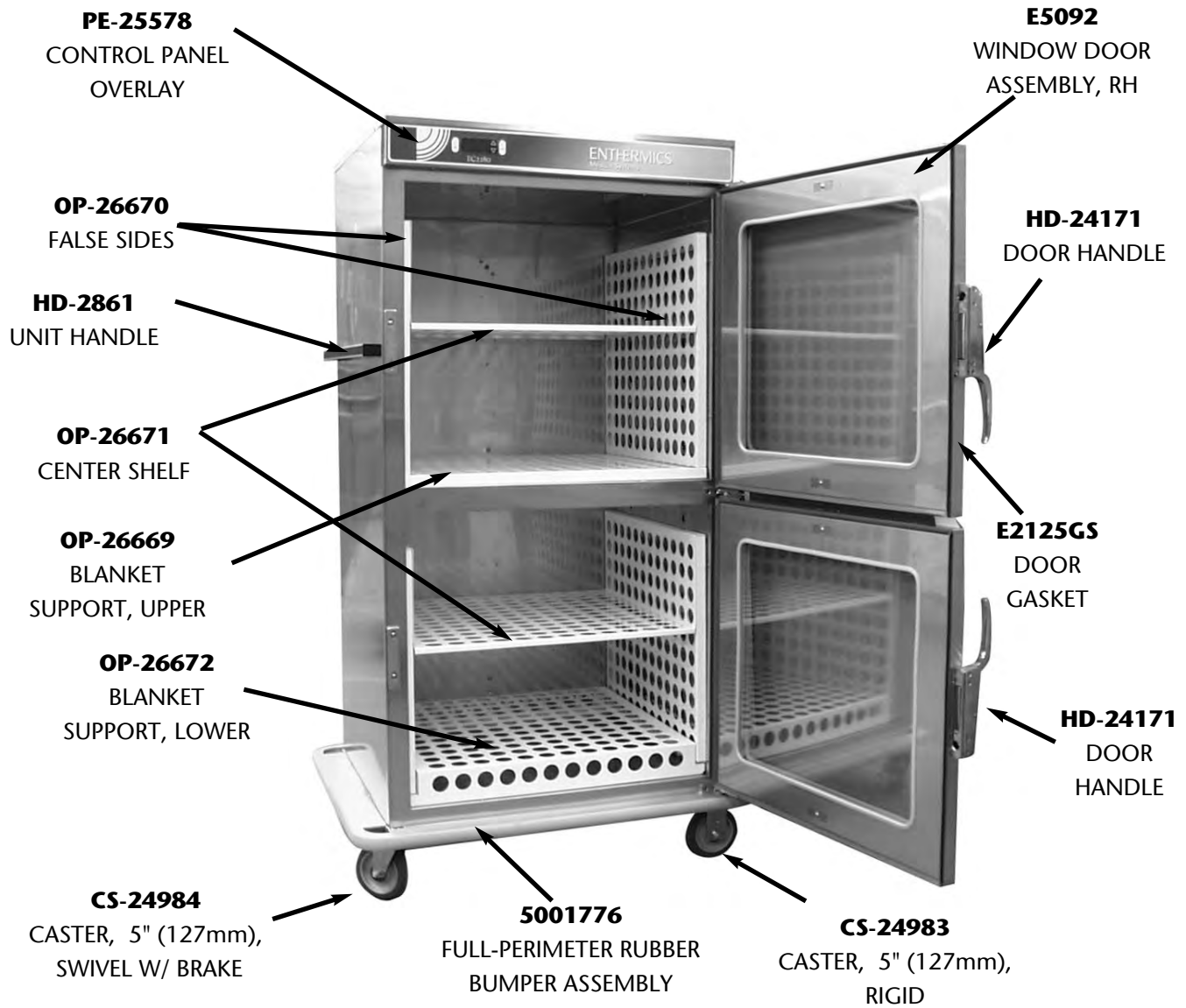

SN-33541
SENSOR



Service View of P-2050

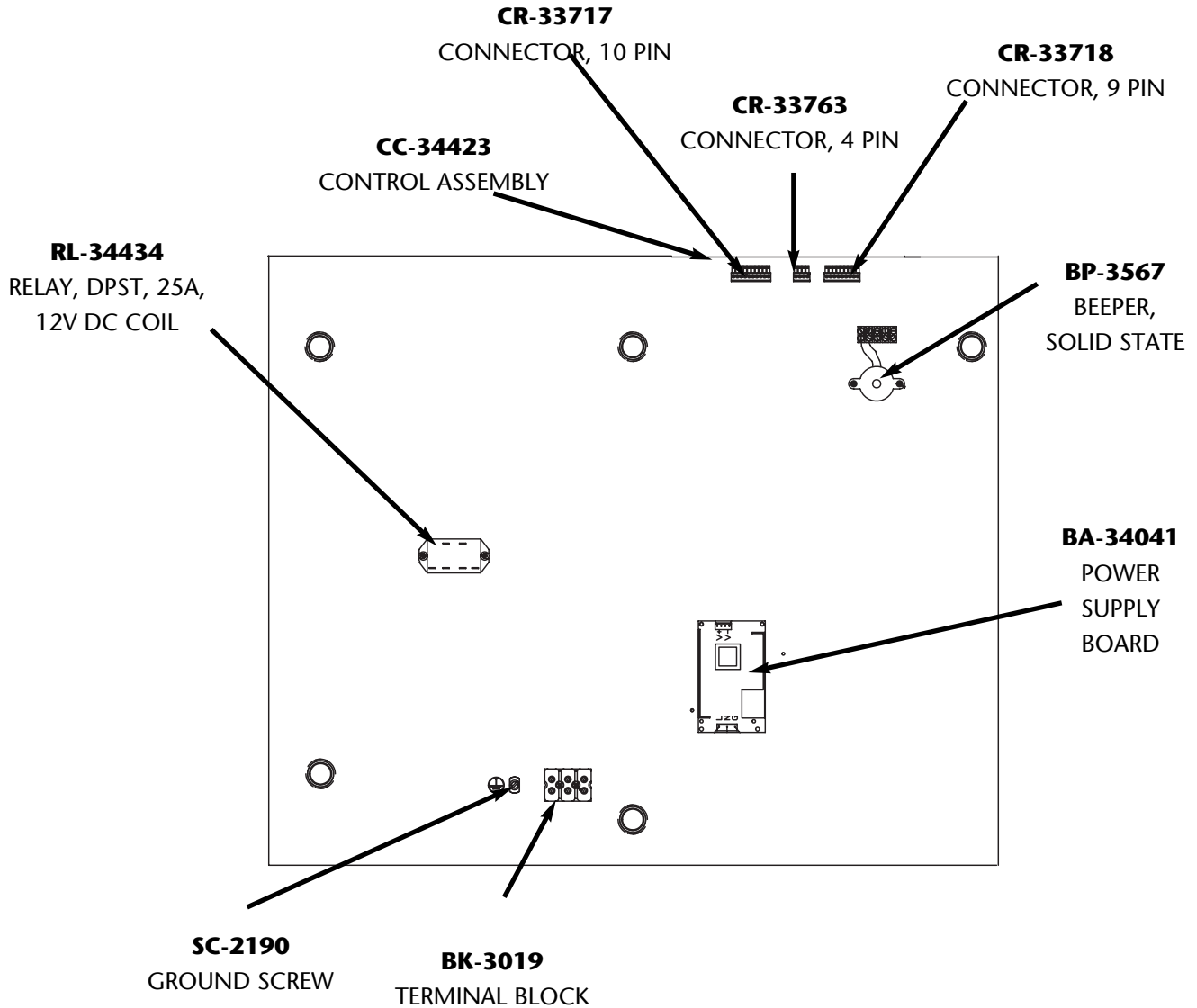

P-2050 Wiring Diagram

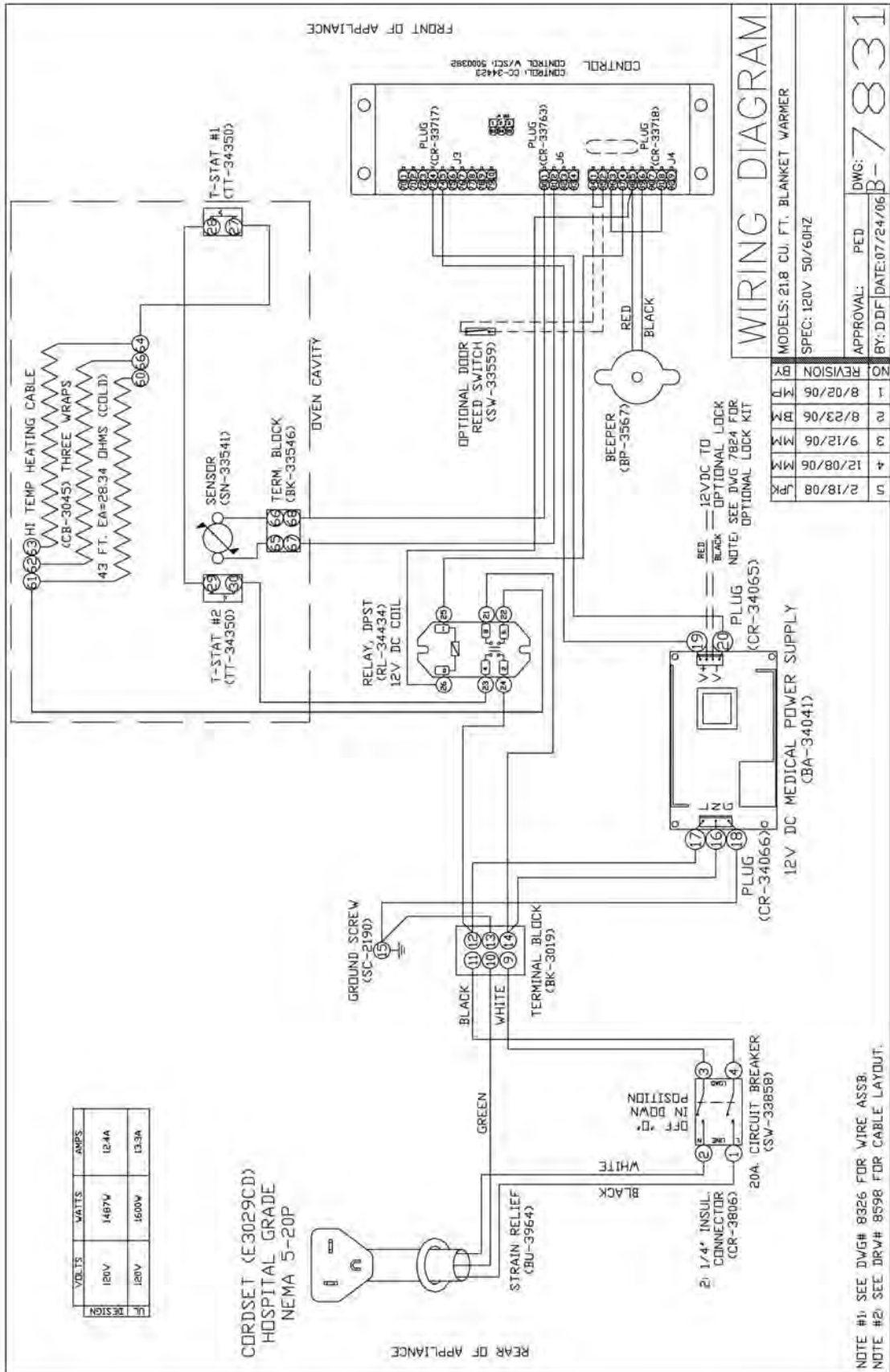

Service View of P-2055

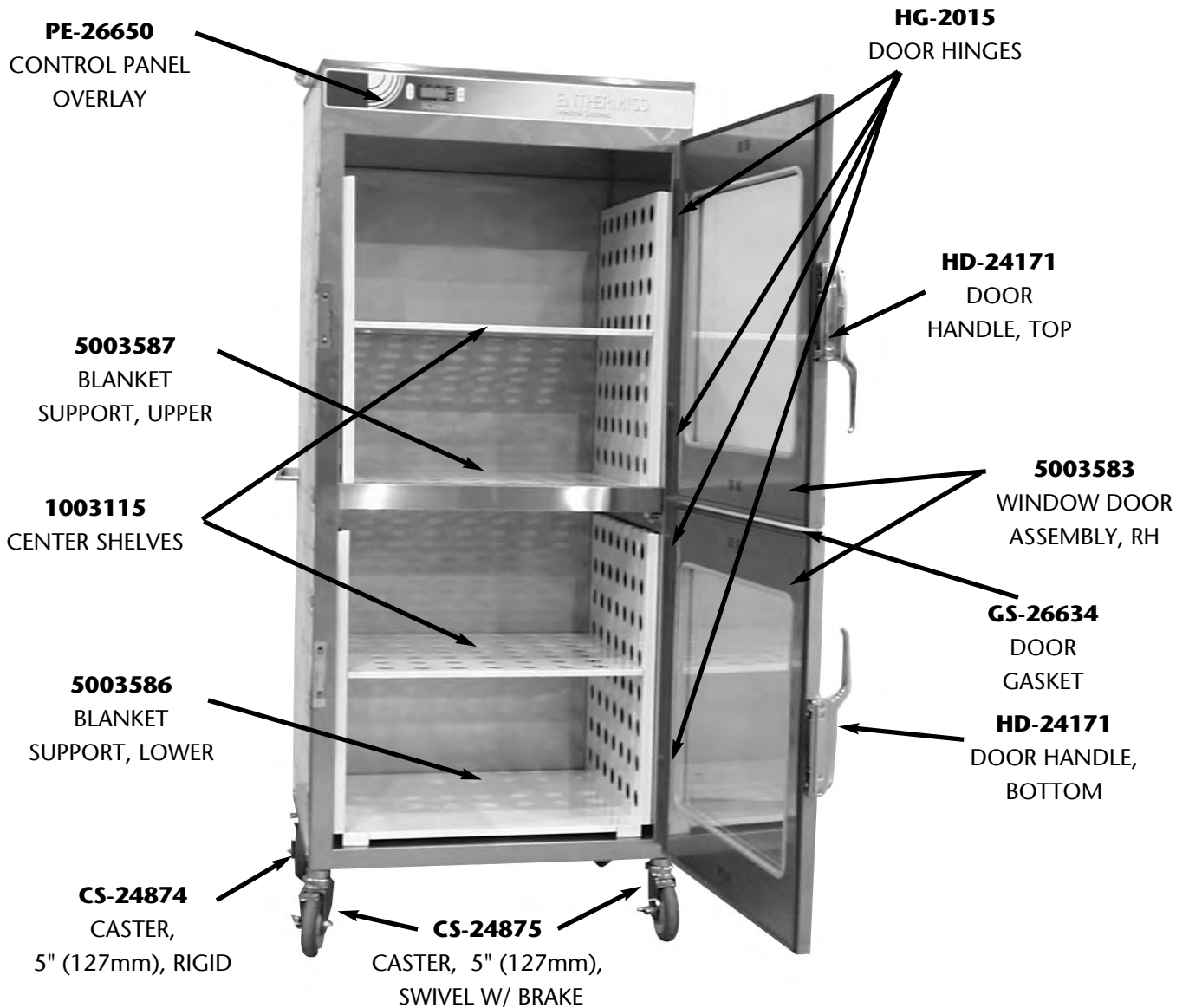

SN-33540
SENSOR



Service View of P-2055

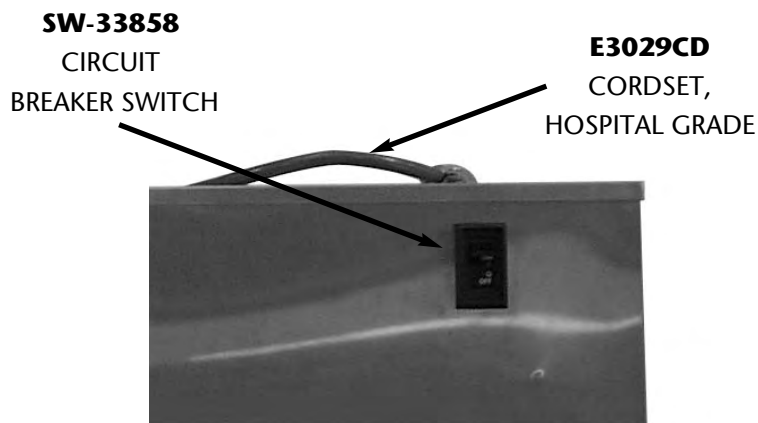
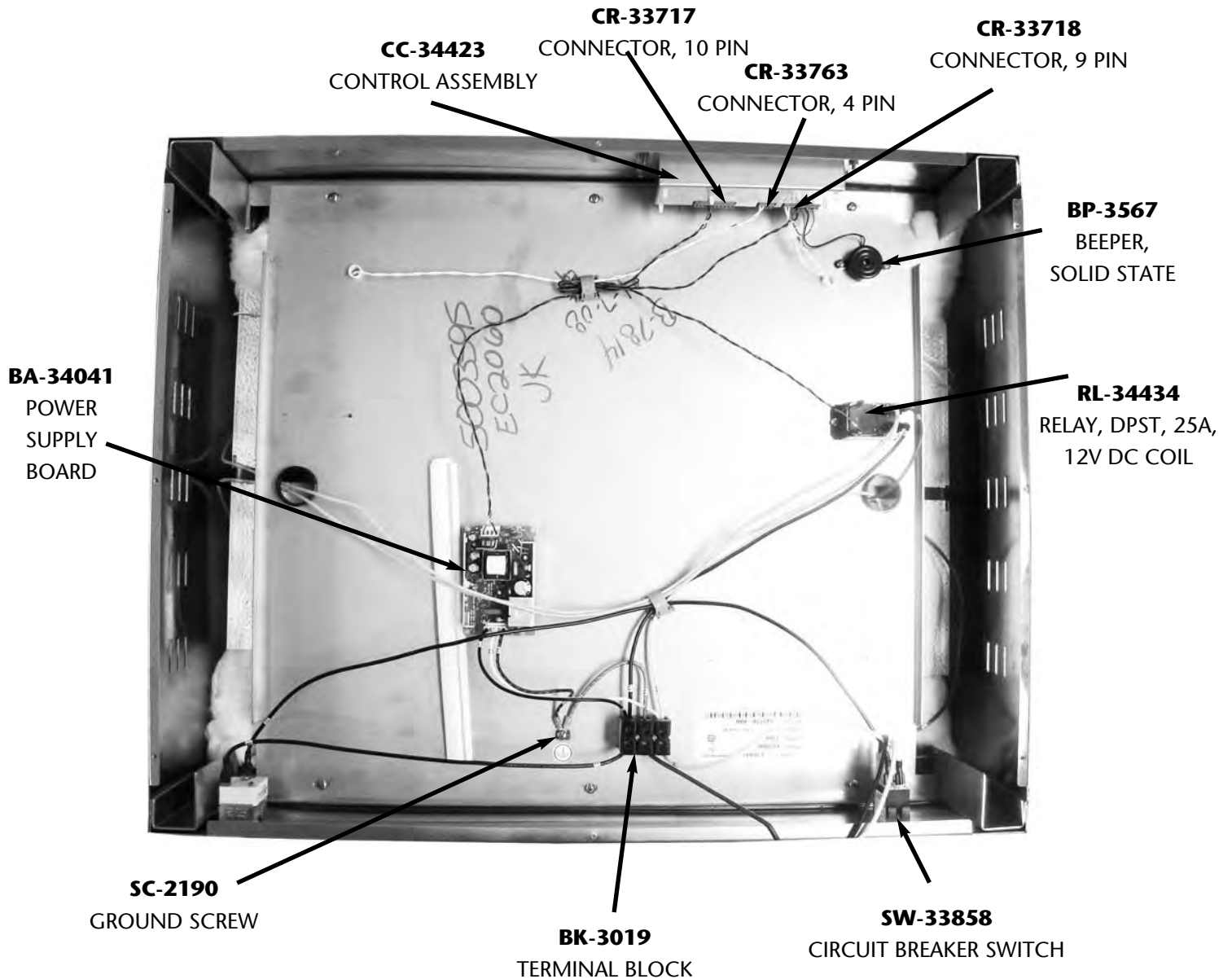

TRANSPORTATION DAMAGE AND CLAIMS

All Pedigo equipment is sold F.O.B. shipping point, and when accepted by the carrier, such shipments become the property of the consignee.

Should damage occur in shipment, it is a matter between the carrier and the consignee. In such cases, the carrier is assumed to be responsible for the safe delivery of the merchandise, unless negligence can be established on the part of the shipper.

1. Make an immediate inspection while the equipment is still in the truck or immediately after it is moved to the receiving area. Do not wait until after the material is moved to a storage area.
2. Do not sign a delivery receipt or a freight bill until you have made a proper count and inspection of all merchandise received.
3. Note all damage to packages directly on the carrier's delivery receipt.
4. Make certain the driver signs this receipt. If he refuses to sign, make a notation of this refusal on the receipt.
5. If the driver refuses to allow inspection, write the following on the delivery receipt:

Driver refuses to allow inspection of containers for visible damage.

6. Telephone the carrier's office immediately upon finding damage, and request an inspection. Mail a written confirmation of the time, date, and the person called.
7. Save any packages and packing material for further inspection by the carrier.
8. Promptly file a written claim with the carrier and attach copies of all supporting paperwork.

We will continue our policy of assisting our customers in collecting claims which have been properly filed and actively pursued. We cannot, however, file any damage claims for you, assume the responsibility of any claims, or accept deductions in payment for such claims.

PEDIGO LIMITED WARRANTY

Pedigo Products, Inc. warrants to the original purchaser that any original part that is found to be defective in material or workmanship will, at our option, subject to provisions hereinafter stated, be replaced with a new or rebuilt part.

The labor warranty remains in effect one (1) year from installation or fifteen (15) months from the shipping date, whichever occurs first.

The parts warranty for the cavity fan motor remains in effect one (1) year from installation or fifteen (15) months from the shipping date, whichever occurs first. The parts warranty on all other parts remains in effect three (3) years from installation or thirty-nine (39) months from the shipping date, whichever occurs first.

This warranty does not apply to:

1. Calibration
2. Equipment damage caused by accident, shipping, improper installation or alteration.
3. Equipment used under conditions of abuse, misuse, carelessness or abnormal conditions including equipment subjected to harsh or inappropriate chemicals including but not limited to compounds containing chloride or quaternary salts, poor water quality, or equipment with missing or altered serial numbers.
4. Any losses or damage resulting from malfunction, including loss of contents or consequential or incidental damages of any kind.
5. Equipment modified in any manner from original model, substitution of parts other than factory authorized parts, removal of any parts including legs, or addition of any parts.
6. Collateral or incidental damage as a direct result of servicing equipment built into a wall structure is not covered under warranty. It is the responsibility of the owner to bear all expense related to structural repairs including, but not limited to, external electrical connections and wiring, and the removal or replacement of caulk, grout, tile, or wall covering of any kind. A service access panel for built-in equipment installations is strongly recommended.

This warranty is exclusive and is in lieu of all other warranties, expressed or implied, including the implied warranties of merchantability and fitness for purpose. In no event shall the Company be liable for loss of use, loss of revenue, or loss of contents or revenue, or for indirect or consequential damages. This warranty is in lieu of all other warranties expressed or implied and Pedigo Products, Inc. neither assumes nor authorizes any persons to assume for it any other obligation or liability in connection with Pedigo Products, Inc. equipment.

Record the model and serial numbers of the unit for easy reference. Always refer to both model and serial numbers in your correspondence regarding the unit.

Model: _____

Serial Number: _____

Purchased From: _____

Date Installed: _____ Voltage: _____



ALL PEDIGO PRODUCTS ARE PROUDLY MADE IN THE USA