

section E-E

No.	Part No.	Explain	Q'ty
1	Welding		1
2	Shell		1
3	Backplane		1
4	Roof		1
5	Bulkhead		1
6	Side panels		2
7	M4X15 Bolt		8
8	Door		1
9	Bulkhead		1
10	Hinge	YKPM1600-FY-05	2
11	Lock hook	YKPM1600-FY-05	1
12	Lock	YKPM1600-FY-05	1
13	M4X6 Screw nut	YKPM1600-FY-05	4

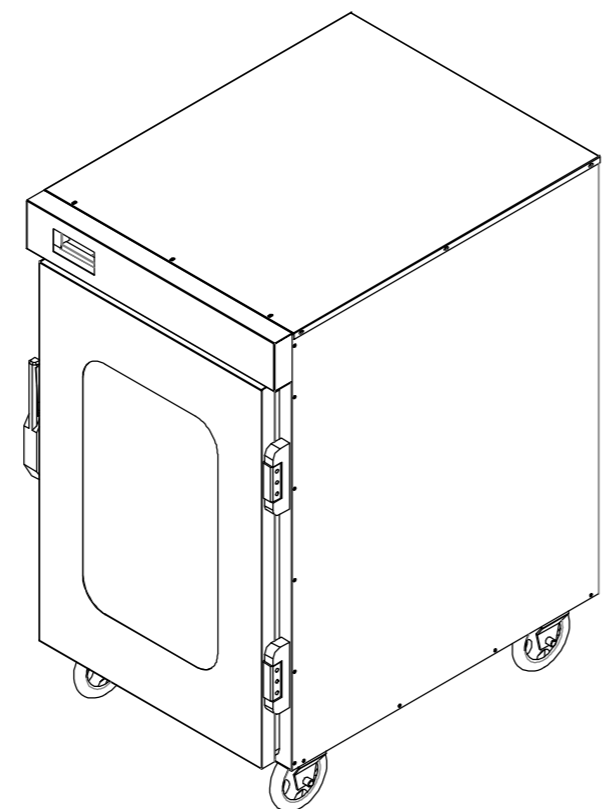

Mark	Q'ty	Change	Date
Design			
Audit			
Crafts			
Approve			

KZ-710		
Stage marked	Q'ty	Scale
	N	1:20
SUS304		